

Upgrading and recovery of fertilizer value of ash from PYRONEER gasification



Raimon Parés Viader

PhD Thesis

Department of Civil Engineering
2016

DTU Civil Engineering Report R-260

Upgrading and recovery of fertilizer value of ash from PYRONEER gasification of low value and difficult biomass feedstock

PhD thesis, 2016



Raimon Parés Viader
Department of Civil Engineering
Technical University of Denmark

Preface

This thesis is the outcome of my PhD study carried out at the Department of Civil Engineering at the Technical University of Denmark (DTU BYG), where I was employed, between May 2013 and August 2016. The main supervisors were Associate Professor Pernille Erland Jensen and Professor Lisbeth M. Ottosen, both from DTU BYG. Senior Scientist Jesper Ahrenfeldt from the Chemical Engineering Department at DTU and Professor Henrik Haugaard-Nielsen from Roskilde University were my co-supervisors.

The PhD thesis is based on four scientific papers in which I am the corresponding author, and one patent application from which I am the main inventor. They are enclosed as a chapter after the References. The structure of the thesis is as follows:

- A common introduction for all publications is found at the beginning (chapter 1), with the knowledge gaps described in chapter 1.4.2
- The results of the core study of this thesis are discussed in common in chapters 2, 3 and in the conclusions, based on the outcome of three of the papers (I, II and III) and the patent application. This part of the investigation was funded by the Energy Technology Development and Demonstration Program (Danish Ministry of Climate, Energy and Buildings) as part of the project “Fuel Flexible, Efficient and Sustainable Low Temperature Biomass Gasification”.
- Paper IV is the result of a research funded by the Danish Environmental Protection Agency (Ministry of Environment and Food of Denmark) as part of the project “Electrodialytic upgrading of MSWI APC residue from hazardous waste to secondary resource”.
- My contributions in two conferences are attached in the Appendix.

Most of the experimental and writing tasks were carried out at the facilities of DTU BYG. Two external stays were performed. One from November to December 2014 at the Department of Chemical and Environmental Engineering, Universidad Técnica Federico Santa María (Chile), hosted by Professor Henrik K. Hansen, under the framework of the EU project ELECTROACROSS. Another one from September to December 2015 at the Department of Civil Engineering of The University of Hong Kong (HKU) hosted by Associate Professor Chuyang Tang, with the economic support of the Reinholdt W Jorck og hustrus Fond for the housing and travelling expenses.

Kongens Lyngby, December 2016

Raimon Parés

Acknowledgements

I wish to acknowledge the Technical University of Denmark, the Energy Technology Development and Demonstration Program (Danish Ministry of Climate, Energy and Buildings) and the Danish Environmental Protection Agency (Ministry of Environment and Food of Denmark) for funding this PhD study. I want also to acknowledge the economic support I received for travelling from Otto Mønsted Fond, the EU project ELECTROACROSS and the the Reinholdt W Jorck og hustrus Fond.

I would like to express my most sincere gratitude to my main supervisor, Associate Professor Pernille Erland Jensen (DTU BYG) for her excellent guidance, support, encouragement, patience and for the confidence placed in me from my hiring until the completion of this PhD. I really appreciate the amount of time and energy that Pernille spent on my supervision and the well-being of everyone, even in never-ending working days. Likewise I am very grateful to my supervisor Professor Lisbeth M. Ottosen (DTU BYG) for her indispensable help, trust and motivation during my time as a PhD student. I would also like to thank my co-supervisors, Senior Scientist Jesper Ahrenfeldt from the Chemical Engineering Department at DTU and Professor Henrik Haugaard-Nielsen from Roskilde University for their assistance and their advices throughout this period. Jesper and the PhD student Tobias Pape Thomsen are highly thanked for supplying me the materials I worked with in my investigations.

I wish to thank laboratory technicians Ebba Cederberg Schnell, Sabrina June Hvid, Malene Grønvold, Natasja Rudbæk Eggertsen, Natasja Dueholm and Camilla Nielsen for their essential and fast assistance in all the experimental work. In general, I want to honour all my colleagues and friends from the Artic technology and sustainable solutions for their help, and for making me feel so welcome during my time at DTU BYG. My colleagues Tobias Pape Thomsen and Benjamin Ebbers (PhD students at DTU), Postdoc Krzysztof Piotr Kowalski as well as Assistant professor at University of Copenhagen Dorette Sophie Müller-Stöver, are thanked for the very interesting discussions we had which became a great source of inspiration for my work.

I would like to express my gratitude to Professor Henrik K. Hansen and PhD student Claudia Gutiérrez Córdova from the Department of Chemical and Environmental Engineering, Universidad Técnica Federico Santa María (Chile), as well as Associate Professor Chuyang Tang, PhD student Guo Hao, Postdocs Jianqiang Wan and Weihua Qing from the Department of Civil Engineering of The University of Hong Kong (HKU) for their hospitality and helpful attitude in my two external stays.

Finally, I owe my deepest gratitude to my parents Janine and Francesc, my sister Elisa, my aunt Francesca, my Uncle Bartolo, my cousins Gilbert, Gerard, Laia and Ferran, my beloved Rita as well as the rest of my family and friends, for always being there for me, no matter what, with their unconditional support and love during all this time I lived abroad. Without you, this work could not have been possible.

Abstract

Low temperature circulating fluidised bed gasifier, alias Pyroneer, allows the production of energy from biomass with high inorganic content like sewage sludge. The use of the resulting Pyroneer ashes in agriculture is important, as they are rich in essential nutrients like P: fertilizer supply is currently dependent on mineral reserves of P, most of which are located outside the European Union. Major concerns are however, the presence of heavy metals and the low plant availability of P in Pyroneer ashes.

Electrodialysis has been studied by other researchers at the Technical University of Denmark as a technique to recover P and remove heavy metals from incineration sewage sludge ashes. In this method, an electrical current is applied to a suspension of ash in an aqueous solution, so as to electromigrate the dissolved ions towards the electrode of opposite polarity. Ion exchange membranes delimitate different compartments and allow the separation of the ionic species, depending on their charge. Thus, P in its neutral to negative forms in solution ($\text{H}_3\text{PO}_4/\text{H}_2\text{PO}_4^-/\text{HPO}_4^{2-}/\text{PO}_4^{3-}$) could be separated from metallic cations, including heavy metals (Cd^{2+} , Cu^{2+} , etc.). Previous results showed that most P was recovered in an acidic solution depleted of metals, which can potentially be used in the fertilizer industry.

The present PhD study aims to investigate the separation of P from heavy metals in different sewage sludge ashes, with focus on the characteristics deciding P solubility and the development of the suitable electro-dialytic method. In total, four ashes produced from three different feedstock were studied:

- One from Pyroneer co-gasification of sewage sludge, in which P was 100% precipitated with phosphate accumulating microorganisms, and wheat straw.
- One from Pyroneer gasification of sewage sludge, in which P was 50% precipitated with Al and Fe salts.
- Two from separate Pyroneer gasification and incineration of the same sewage sludge, the P of which was 30% precipitated with Fe salts.

The results showed that significant amounts of Al/Fe(III)-phosphates could be found through an alkaline leaching in the two ashes from gasification of sewage sludge with chemically precipitated P. In contrast, a considerable lower proportion of Al/Fe(III)-phosphates were found for the incineration sewage sludge ashes, whereas Ca was found to control P solubility at low pH for the ash with biologically precipitated P.

Using a 2-compartment electro-dialytic cell, in which the ash suspension was acidified, over 80% of P could be recovered from both the Pyroneer ashes with biologically precipitated P and the incineration sewage sludge ashes. However, P recovery was limited to a 40% for the other two ashes using the same setup, which was due to the higher presence of Al/Fe(III)-phosphates. In order to increase the extraction of P for these ashes, an innovative electro-dialytic method was designed, for which a patent application was filed. In this new technique, a 2-compartment cell was combined sequentially with a second cell, in which the ash suspension was alkalinised in order to dissolve Al/Fe(III)-phosphates, achieving a recovery of up to 70% of P. The final recovery product in all cases was a diluted H_3PO_4 acid solution (<10 g P/L) with a lower ratio of metallic impurities than in the original ash. Further modifications of the electro-dialytic cell allowed a reduction of the ratios of most metals to P to the levels of wet process phosphoric acid, widely used in the manufacturing of fertilizers.

Several other improvements can entail a higher % of P recovery and an optimisation of the electricity consumption. Another membrane technique (forward osmosis) can also increase the concentration of P with minor energy consumption. Nevertheless they need to be addressed in future studies.

Resumé

Pyroneer forgasning kan bidrage til energiproduktionen fra biomasse med et højt uorganisk indhold, så som spildevandsslam. Muligheden for genanvendelse af den aske, som produceres under Pyroneer forgasning, er vigtig for landbruget, eftersom asken er rig på næringsstoffer som bl.a. fosfor (P): på nuværende tidspunkt er forsyningen af gødning afhængig af mineralske reserver af P, hvoraf de fleste er placeret uden for EU. En problemstilling for genanvendelse af asken er dog indholdet af tungmetaller og den lave plantetilgængelighed af P i Pyroneer asken.

Elektrodialyse er tidligere blevet undersøgt af andre forskere på DTU som en teknik til at udvinde P og til at fjerne tungmetaller fra forbrænding af aske fra spildevandsslam. Ved elektrodialyse tilføres en elektrisk strøm til en suspension af aske i en vandig opløsning, for at elektromigrere de opløste ioner mod elektroden med modsat polaritet. Ionbyttermembraner kan afgrænse forskellige rum og tillade separation af ioner, afhængigt af disses ladning. Med denne metode kan P i dens neutrale eller negative form ($H_3PO_4/H_2PO_4^-/HPO_4^{2-}/PO_4^{3-}$) adskilles fra metalliske kationer, herunder tungmetaller (Cd^{2+} , Cu^{2+} etc.). Tidligere studier har vist, at størstedelen af P udvindes i en sur opløsning, hvorfra metaller er fjernet. Der er potentiale for, at den udvunde P kan genanvendes i gødningsindustrien.

Dette Ph.d.-projekt har til formål at undersøge adskillelse af P fra tungmetaller i aske fra forskellige spildevandsslam. Fokus er på de karakteristika, der afgør P-opløselighed samt udviklingen af egen elektrodialytisk metode. I alt er fire asker fremstillet af tre forskellige råmaterialer blevet undersøgt:

- Aske fra Pyroneer co-forgasning af spildevandsslam, hvor P var 100 % udfældet med fosfat-akkumulerende mikroorganismer og hvedehalm.
- Aske fra Pyroneer forgasning af spildevandsslam, hvor P var 50 % udfældet med Al- og Fe-salte.
- To asker fra uafhængige Pyroneer forgasninger og forbrændinger af samme spildevandsslam, hvoraf 30 % af P var udfældet med Fe-salte.

Resultater fra alkalisk udvaskning viste, at de to asker fra forgasning af spildevandsslam med kemisk udfældet P indeholdt betydelige mængder af Al/Fe(III)-fosfat. I modsætning hertil kan en betydelig lavere andel af Al/Fe(III)-fosfat detekteres for aske fra forbrænding af spildevandsslam. Undersøgelserne viste desuden, at opløseligheden af P i asken med biologisk udfældet P ved lav pH blev styret af calcium.

Ved hjælp af en todelt elektrodialytisk celle, hvor askesuspensionen blev syret, kunne mere end 80 % af P udvindes fra både Pyroneer-asken med biologisk udfældet P og asken fra forbrænding af spildevandsslam. Imidlertid blev P nyttiggørelsen begrænset til 40 % for de to resterende asker under anvendelse af samme fremgangsmåde, hvilket skyldtes den højere andel af Al/Fe(III)-fosfat. For at øge udvindingen af P fra disse asker, blev der designet en innovativ elektrodialytisk metode, for hvilken der er blevet indleverede en patentansøgning. Ved denne nye teknik blev en todelt celle sekventielt kombineret med en anden celle, i hvilken askesuspensionen blev alkaliseret for at opløse Al/Fe(III)-fosfat. Dermed blev der opnået en nyttiggørelse af P på op til 70 %. I samtlige tilfælde var det resulterende genanvendelige produkt en fortyndet H_3PO_4 -syreopløsning (<10 g P/L) med en lavere andel af metalliske urenheder end den oprindelige aske. Yderligere modifikationer af den elektrodialytiske celle tillod en reduktion af forholdene mellem de fleste metaller og P til niveauer svarende til de mest almindelige fosforsyrer brugt i fremstillingen af gødning.

Videreudvikling af denne innovative metode kan medføre en højere procentmæssig nyttiggørelse af P samt en reduktion af elforbruget. En anden membran-teknik (direkte osmose) kan ligeledes øge koncentrationen af P med et lavere energiforbrug. Begge metoder bør dog undersøges nærmere.

Table of Contents

| | |
|--|-----|
| Preface..... | i |
| Abstract | iii |
| Resumé..... | v |
| List of abbreviations | ix |
| 1. Introduction..... | 1 |
| 1.1 Waste management and thermal treatment..... | 1 |
| 1.2 Gasification of waste - Pyroneer technology | 2 |
| 1.3 Phosphorus in the society | 3 |
| 1.3.1 <i>Supply in agriculture</i> | 3 |
| 1.3.2 <i>Recirculation from incineration SSAs</i> | 4 |
| 1.3.3 <i>Solubility in SSAs</i> | 5 |
| 1.4 Eletrodiaytic method..... | 6 |
| 1.4.1 <i>Existing setups</i> | 6 |
| 1.4.2 <i>Knowledge gaps</i> | 8 |
| 1.4.3 <i>Parameters in the solid suspension affecting the overall ED performance</i> | 8 |
| 1.5 Visual MINTEQ simulations | 10 |
| 2. SSA characterization..... | 12 |
| 2.1 Element concentration | 12 |
| 2.2 Compounds in the SSA..... | 14 |
| 2.3 pH solubility of the elements | 16 |
| 2.4 Acid-alkaline extraction of P..... | 17 |
| 3. Electrodialytic remediation of SSAs..... | 20 |
| 3.1 Setups investigated | 20 |
| 3.2 P-liquids produced..... | 23 |
| 3.3 Potential further developments..... | 25 |
| 3.3.1 <i>P recovery in the sequential process</i> | 25 |
| 3.3.2 <i>K loss during Stegholdt SSA treatment</i> | 26 |
| 3.3.3 <i>Energy consumption during ED</i> | 27 |
| 3.3.4 <i>Other outputs from the electrodialytic experiments</i> | 30 |
| 3.3.5 <i>Low P concentration in the anolytes</i> | 32 |
| 4. General conclusions..... | 34 |

| | |
|--|-----|
| References | 35 |
| Own publications..... | 40 |
| Paper I - Electrodialytic extraction of phosphorus from ash of low-temperature gasification of sewage sludge..... | 41 |
| Paper II - Sequential electrodialytic recovery of phosphorus from ashes of low-temperature gasification of chemically precipitated sewage sludge | 53 |
| Paper III - Comparison of phosphorus recovery from incineration and gasification sewage sludge ash | 63 |
| Paper IV - Electrodialytic remediation of municipal solid waste incineration residues using different membranes..... | 79 |
| Publication V - Patent application - Sequential electrodialytic extraction of phosphorus compounds.. | 89 |
| Appendix – conference contributions | 139 |

List of abbreviations

| | |
|---------|--|
| 2C | 2-compartment |
| AEM | Anion exchange membrane |
| APC | Air pollution control |
| BA | Bottom ashes |
| Bio-P | Biologically precipitated phosphorus |
| CEM | Cation exchange membrane |
| Chem-P | Chemically precipitated phosphorus |
| DAP | Diammonium phosphate |
| DI | De-ionized |
| DS | Draw solution |
| ED | Electrodialysis, Electrolytic |
| EU | European Union |
| FA | Fly ashes |
| FO | Forward osmosis |
| FS | Feed solution |
| HM | Heavy metal |
| HM/P | Heavy metal to phosphorus ratio |
| ICP-OES | Inductively coupled plasma optical emission spectrometry |
| IE | Ion exchange |
| IEM | Ion exchange membrane |
| IFA | International Fertilizer Association |
| L/S | Liquid to solid ratio |
| LOD | Limit of detection |
| LT-CFB | Low-temperature circulating fluid bed |
| M/P | Metal to phosphorus ratio |
| MAP | Monoammonium phosphate |
| MER | Minor element ratio |
| MSF | Multi-stage flash distillation |
| MSW | Municipal solid waste |
| P-rock | Phosphate rock |
| RO | Reverse osmosis |
| SEM | Scanning electron microscope |
| SSA | Sewage sludge ash |
| WPA | Wet process phosphoric acid |
| WWTP | Wastewater treatment plant |
| XRD | X-ray diffraction |
| XRPD | X-ray power diffraction |

1. Introduction

1.1 Waste management and thermal treatment

Thermal treatment of waste is a common strategy in developed countries [1, 2]. From a waste management point of view, it has less priority than other actions like prevention or recycling (Fig. 1). Yet, it is better than direct disposal, because it allows a reduction of up to 90% of waste volume, destroys most organic contaminants and allows some energy recovery from the waste [1-6]. Among all the existing thermal technologies, incineration (or combustion) is the most commonly implemented [5]. For instance, in 2013 in Denmark, more than 11 million tonnes of waste were produced, 27% of which was incinerated and 66% was recycled, according to the Danish Environmental Protection Agency [7]. The rest was either directly landfilled or received a different treatment.

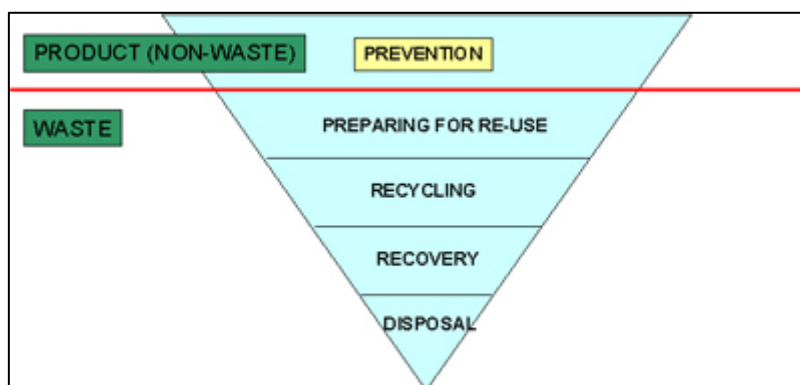

Fig.1 Waste management hierarchy defined in the directive 2008/98/EC on waste.

As a result of the thermal treatment, waste ashes are generated: mainly bottom ashes (BA), fly ashes (FA) and/or air pollution control (APC) residues. A commonly incinerated waste is municipal solid waste (MSW), the ashes of which are treated differently nowadays. Most MSW BA are used in construction material in Denmark [8]. In contrast, MSW FA and APC residues are exported for final utilisation to Norway or Germany, as they are considered hazardous due to the heavy metal (HM) content and leachability and the presence of persistent organic pollutants [9]. Another waste which is usually incinerated in many western countries is sewage sludge. The resulting sewage sludge ash (SSA) is generally considered harmless. Among other reasons, for a considerably lower HM content compared to MSW FA or APC residues. Thus, SSAs are commonly landfilled or used as construction materials in some places like Germany, the biggest SSA producer in the EU [10]. However, such practices imply the loss of some valuable and non-renewable elements present in SSA like P, Cu or Zn [11].

1.2 Gasification of waste - Pyroneer technology

Apart from incineration, another thermal process available is gasification, where the carbonaceous content in waste is converted into syngas in a reductive atmosphere. Nowadays there are around 100 MSW gasification plants worldwide, most of them operating at 1,100°C or higher and located in Japan [12]. Another technology directly related to gasification is pyrolysis, in which the organic content of a material is thermally converted to char, gas and tar/oil in a total absence of oxygen. Gasification and pyrolysis of sewage sludge are not yet as expanded as MSW gasification, but it has been growing over the last two decades. Table 1 summarizes some prominent examples of plants using these technologies to treat municipal sewage sludge.

Table 1. Existing sewage sludge gasification/pyrolysis plants.

| Place | Operational since | Technology | Feedstock | Operational use/capacity (tonnes/year) |
|-------------------|---------------------------|---------------------------|-------------------------|--|
| Tokyo, Japan | 2010 | Gasification at 800°C | Dewatered sewage sludge | 36,500 |
| Hiroshima, Japan | 2012 | Pyrolysis at 250-350°C | | 28,000 |
| Balingen, Germany | 2000 (upscale in 2010) | | | 2,300 |
| Mannheim, Germany | 2014 | Gasification at 850-880°C | Dried sewage sludge | 5,000 |
| Koblenz, Germany | 2016 (commissioning) | | | 4,500 |

A potential alternative to conventional gasification methods is the low-temperature circulating fluid bed (LT-CFB) gasifier, also known as Pyroneer. This technology consists of separate pyrolysis and gasification reactors, which operate at lower temperatures than other gasification process (Fig. 2). This prevents the melting of the inorganic content in materials like straw or sewage sludge, and the consequent formation of deposits, a common problem in other thermal processes operating at higher temperatures [4, 13]. A 500 kW pilot plant is installed at Roskilde campus of the Technical University of Denmark (DTU), where cold gas efficiencies of around 90% were achieved with different feedstocks [14]; all Pyroneer SSAs investigated in this thesis were produced in this gasifier. A 6 MW unit operated from 2011 [14] until 2014 at DONG Energy's Asnæsværket power plant Kalundborg. The char/ash resulting from a LT-CFB gasifier has a potential fertilizer value due to its content of interesting nutrients like recalcitrant carbon (which can also mitigate the effect of climate change), P or K [15, 16]. However, its usage can be limited due to the presence of heavy metals (HMs) and the potential low plant availability of P, as it is the case for incineration SSAs [17, 18]. A characterisation of Pyroneer SSAs, produced from different feedstocks, and a comparison to incineration SSA is presented in chapter 1.

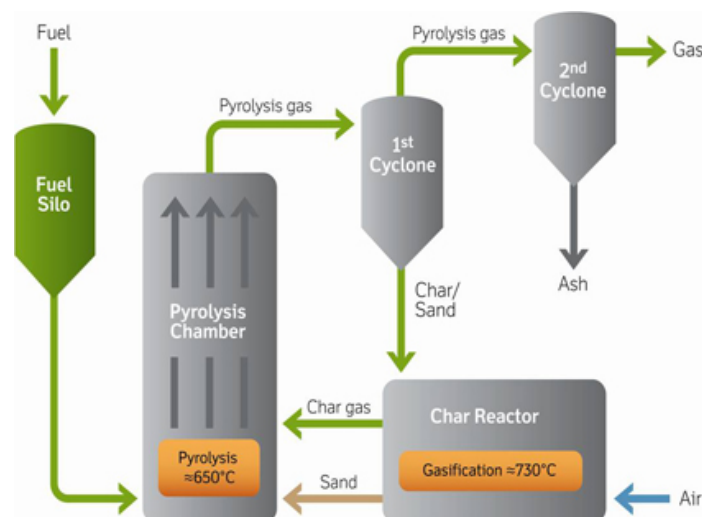

Fig.2. Schematic of experimental LT-CFB gasifier (Pyroneer) [19].

1.3 Phosphorus in the society

1.3.1 Supply in agriculture

Phosphorus is an essential nutrient for life and a non-renewable resource. Its input in agricultural soils is dependent on phosphate rock (P-rock) [20], a mineral which is unevenly distributed in the world, and that is predicted to be depleted in a range of 50–400 years [21]. It is also a critical raw material for the European Union (EU) countries, as they import around 90% of the P-rock they consume according to the International Fertilizer Association (IFA). Over 80% of this mineral is used to produce fertilizers [20], and the most common route to process P-rock is through the acid leaching with H_2SO_4 , resulting in the production of wet process phosphoric acid (WPA) [20, 22]. This method entails also a massive generation of waste: for every tonne of P_2O_5 , around 5 tonnes of phosphogypsum are produced, a radioactive material which can rarely be recycled nowadays [20]. WPA is then mixed with ammonia to produce mono- and diammonium phosphate (MAP and DAP) [22]. Overall, ammonium phosphates represent more than 50% of the P-fertilizer consumption worldwide according to the IFA.

P-fertilizers are known to have high content of trace elements like HMs. Table 2 shows the ratio of some HMs to P (HM/P) found in WPA and in some common fertilizers. Although the impurity level in WPA is very dependent on the original P-rock used, As/P, Cr/P, Cu/P and Zn/P in these fertilizers are in the range of WPA (Table 2). This shows a clear transfer of some HMs from P-rock to fertilizers, which can potentially accumulate in agricultural soils and the food chain [23, 24]. Moreover, HM/P in WPA or fertilizers are normally higher than, for example, H_3PO_4 used in the food industry [22]. This is because WPA is used in the production of fertilizers with virtually no HM purification [22]. Among all elements, Cr and Zn are the ones with the highest content in fertilizers, with values above 100 mg/kg P.

Table 2. HM content (mg/kg P) in WPA and commercial fertilizers.

| | WPA [22] | MAP [25] | DAP [25] | Other NPK fertilizers [26] |
|----|------------|----------|----------|----------------------------|
| As | 20-70 | 38-88 | 66-93 | 46-137 |
| Cd | 120-500 | 11-21 | 17-25 | 12-60 |
| Cr | 100-3,000 | 362-384 | 396-488 | 125-794 |
| Cu | 10-400 | 8-15 | 7-28 | 10-80 |
| Ni | 100-700 | 8-50 | 11-57 | 42-168 |
| Pb | <4 | 17-30 | 24-72 | 9-53 |
| Zn | 100-10,000 | 131-401 | 189-221 | 291-1,080 |

1.3.2 Recirculation from incineration SSAs

In recent years, several initiatives have appeared in Europe so as to ensure the supply of P from alternative sources. Under the framework of one of the most ambitious existing waste strategies, the Danish government set a target for 2018 of 80% P-recovery from sewage sludge [27]. The recycling from SSAs has an important role in this goal, since 27% of sewage sludge is incinerated in Denmark [7]. For instance, around 7,000 tonnes of incineration SSAs are produced every year in the two biggest sewage sludge incineration plants in Denmark, located in Copenhagen area [28]. Moreover, it is estimated that around 270,000 tonnes of SSAs are deposited in their landfills [29], which are almost at full capacity.

Direct usage of SSA as fertilizer is limited due to the low plant availability of the present P-compounds, and the presence of HMs [17, 18]. Therefore, a separation of P from the bulk SSA is necessary for its recycling. The processing of SSAs cannot be carried out with the conventional acid route used for P-rock, due to the high content in Al, Fe and Mg, and the parallel solubilisation of HMs [20, 30], which would lead to an H_3PO_4 with a high amount of impurities. In the industry, a parameter (minor element ratio, MER) is defined to evaluate the suitability of H_3PO_4 solutions to produce some common fertilizers. In the case of DAP, the most consumed fertilizer worldwide, there is a technical limit for MER of 0.085 [22]:

$$MER = \frac{Fe_2O_3 + Al_2O_3 + MgO}{P_2O_5} < 0.085$$

Recycling of P from incineration SSAs has been widely investigated, and the techniques existing at pilot scale were studied and compared in the EU FP7 project P-REX until 2015. The most common methods are known as wet processes: they comprise the leaching of P from SSA using different acids (H_2SO_4 , HCl, HNO_3 , oxalic acid or H_3PO_4) [17], followed up by purification steps to remove Al, Fe, Mg or HMs using ion exchange (IE) columns, solvent extraction or sulfidic precipitation [31]. Nowadays, there are three projects ongoing in Europe to recover P from SSAs at a pilot scale (Table 3), where the final products are concentrated H_3PO_4 . The biggest one started last year as a collaboration between the Belgian company Ecophos and the Dutch companies HVC and SNB, which will aim to treat 50-60,000 tonnes of incineration SSAs yearly. With the information available in the patents for two of the processes, it was estimated that the MER value is higher than 0.085 and/or the recovery of P is slightly below the values found in literature, which is normally above 80% [31, 32] (Table 3). It has to be noted that both technologies were applied to

Fe-rich incineration SSAs, which can have different P solubility than gasification or Al-rich SSAs [31] (see next chapter).

Table 3. European pilot plant projects to recover P from SSA using wet processes.

| Cooperation | Place | Starting | Purification step | %P extracted from SSA* | MER*,** |
|---------------------------------------|---------------------|----------|--------------------|------------------------|---------|
| Remondis, HAMBURG WASSER | Hamburg, Germany | 2015 | IE columns | 68% | 0.05 |
| ZAR, Técnicas Reunidas, Zürich Canton | Zürich, Switzerland | 2016 | Solvent extraction | - | - |
| Ecophos, HVC, SNB | Dunkirk, France | 2017 | IE columns | 75% | 0.12 |

*Estimated with the information available in the patents [33, 34]. ** Only the extracted part is taken into account in the calculation.

1.3.3 Solubility in SSAs

A key parameter to understand technologies of P recovery from SSAs is the solubility of the different phosphate compounds. In wastewater treatment plants (WWTP), P is removed in order to prevent the eutrophication of water ecosystems. This is done by precipitation using Al or Fe salts as well as P-accumulating microorganisms [35-37]. How much of each method is used influences the plant availability of the P in the sewage sludge, since the solubility of solid P compounds vary considerably depending on the P anion form (i.e. PO_4^{3-} or HPO_4^{2-}) and the cation to which it is bound (i.e. Al, Ca or Fe(III)), as seen in Fig. 3. Another decisive factor is the pH of the medium. For example, Al-, Ca- and Fe(III)- phosphates have a low solubility at neutral pH (Fig. 3), and are not bioavailable [38], in contrast with water soluble fertilizers like MAP, DAP (NH_4HPO_4 , $(\text{NH}_4)_2\text{HPO}_4$) or triple superphosphate ($\text{Ca}(\text{H}_2\text{PO}_4)_2$), which exhibit a good plant availability [20].

P solubility in sewage sludge is likely to change after a thermal treatment. During incineration, existing Fe-phosphates react with calcium oxide to form Ca-phosphates and hematite (Fe_2O_3) [3, 39]. Hematite is acid-insoluble and gives the characteristic red colour to Fe-rich incineration SSAs; this conversion also eases P-recovery through acid leaching, as Ca-phosphates have a higher solubility at low pH than Fe(III)-phosphates (Fig. 3). In a previous research about gasification SSAs, standfieldite ($\text{Ca}_4(\text{Mg,Fe})_5(\text{PO}_4)_6$) and not hematite was identified in the x-ray powder diffraction (XRPD) of SSAs from the gasification of Fe(II)-P containing sewage sludge in the absence of air; at the same time, the ashes had a grey tone [40]. On the contrary, hematite was identified, the intensity of standfieldite peaks in the XRPD significantly decreased and a reddish colour was observed when air was used in the process [40]. Thus, a direct correlation can be expected between the amount of oxygen used and the break of Fe-P bindings in thermal processing of sewage sludge.

Al-phosphates, which also have a lower solubility than Ca-phosphates at acidic pH (Fig. 3), have been identified in incineration SSAs when Al salts are used in the WWTP [31, 39, 41]. New Al-P bindings were found likely to form for these SSAs during an acidic extraction after P and Al release from other compounds [31, 41]. A similar mechanism can be expected for Fe(III) and P, which would imply that P solubility can be influenced by both Al/Fe(III)-P bindings and acid-soluble Al/Fe(III) compounds. Moreover, solubilised Fe(III) and Al ions tend to form complexes with P at acidic pH, which complicate its separation through ion exchange technologies [32]. Thus, separation of Al/Fe and P in these two kinds of SSAs cannot be properly done in an acidic extraction. An alternative is to work at alkaline pH, because Al/Fe(III)-phosphates are soluble, Ca-phosphates are highly insoluble (Fig. 3 and [31, 42]) and no metallic phosphate complexes are expected (chapter 1.5). However, solubilised P in an alkaline step could bind to mainly Ca-compounds or re-precipitate as Ca-P [41, 43-45]. An extraction method to deal with SSAs containing Ca- and Al/Fe(III)-phosphates is presented and discussed in chapter 2.4.

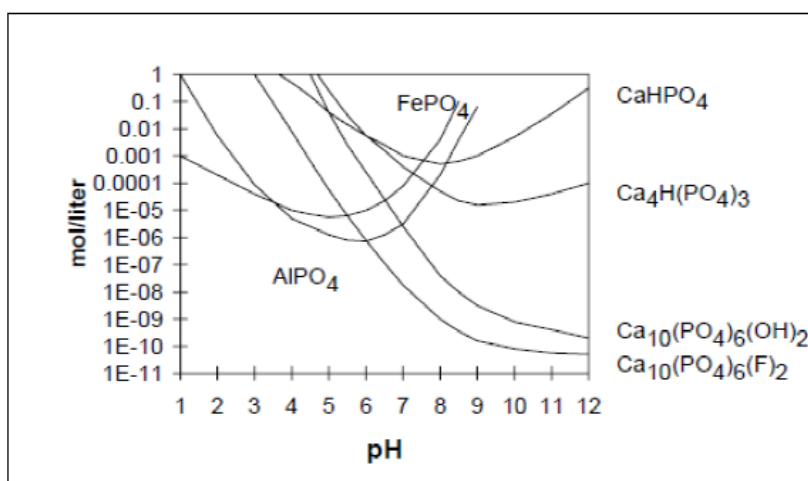

Fig. 3. Al-, Ca- and Fe(III)- phosphates solubility at different pH values [46].

1.4 Eletrodiaytic method

1.4.1 Existing setups

Electrodialysis (ED) is an electrochemical technique involving the transport of ions, through ion exchange membranes (IEMs) and by means of an electrical potential difference. Under the effect of the electrical current, cations migrate towards to cathode, and anions migrate towards the anode. At the same time, IEMs are hydrophobic membranes that selectively reject cations (anion exchange membranes, AEM) or anions (cation exchange membrane, CEM), and that are placed so as to separate different liquid solutions. Thus, the mobilisation of ionic species from one solution to another can be achieved. ED is widely conceived in a stack configuration (Fig. 4), consisting of several compartments delimited by alternated CEM and AEM and flow spacers (Fig. 4). The liquid to be treated ("Salt solution" and "Diluate" in Fig.4a and 4b) enters into these compartments through holes strategically placed in the spacers, as seen in Fig. 4b. This

configuration allows a high contact membrane area with the solution to treat, and it is typically used in brackish water desalination, salt recovery from seawater, water softening or whey desalination [47]. However, such setup is likely to have operational problems while treating particulate matters like suspensions of SSA and water: narrow intermembrane space (usually <1mm) and small spacer holes may difficult the circulation of the material to treat, leading to its deposition and subsequent membrane fouling. Therefore, a different strategy is needed.

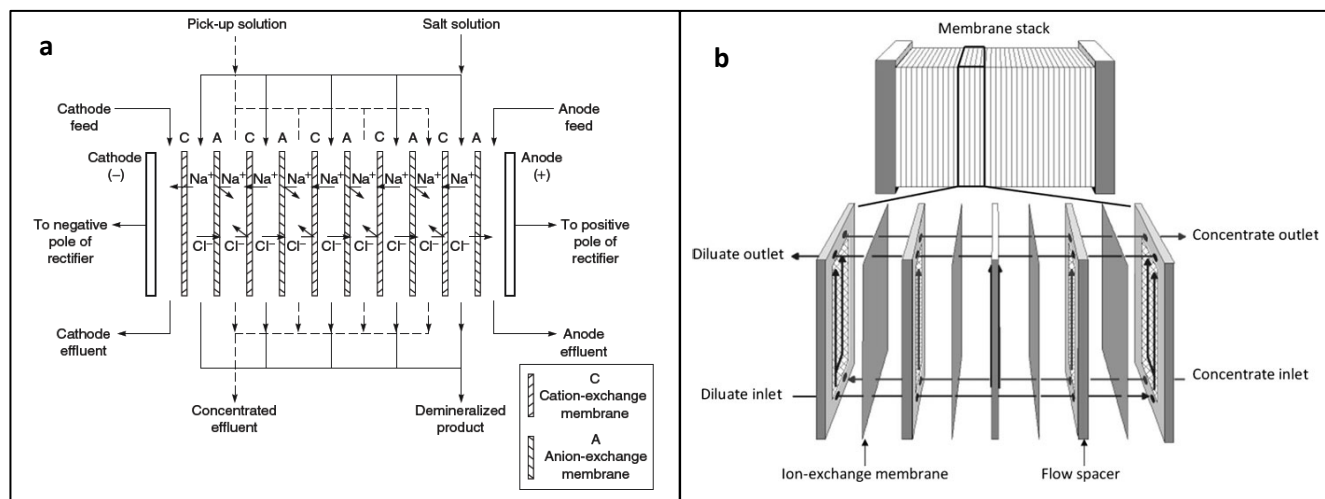
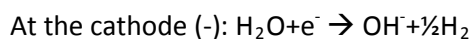
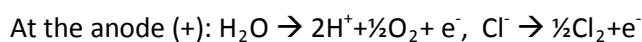

Fig. 4a: ED principle in a stack setup [47], 4b: Configuration of the IEMs and spacers in an ED stack [48].

Different ED setups, suitable for the treatment of polluted solids, have been investigated and developed at DTU since the 1990s (Fig. 5a-d). In these configurations, a mixture of liquid and particulate materials is continuously stirred in a single compartment where there is a longer distance between the membranes than in a conventional ED stack (normally 10 cm at lab scale); thus, particle settling is avoided. The other compartments are filled with an electrolyte solution to allow the pass of electrical current, and they are separated from the other compartments with IEMs (Fig. 5a-d). The number of compartments depends on the final objective of the ED process. For example, if only cations need to be removed from a solid suspension (Fig. 5c) or to avoid Cl_2 gas formation (see below) in the anode with migrated Cl^- (Fig. 5a). In addition, the production of H^+ and OH^- at the electrodes can be used to shift the pH of the suspension if one of the 2-compartment (2C) ED cells (Fig. 5c and 5d, respectively) is used:



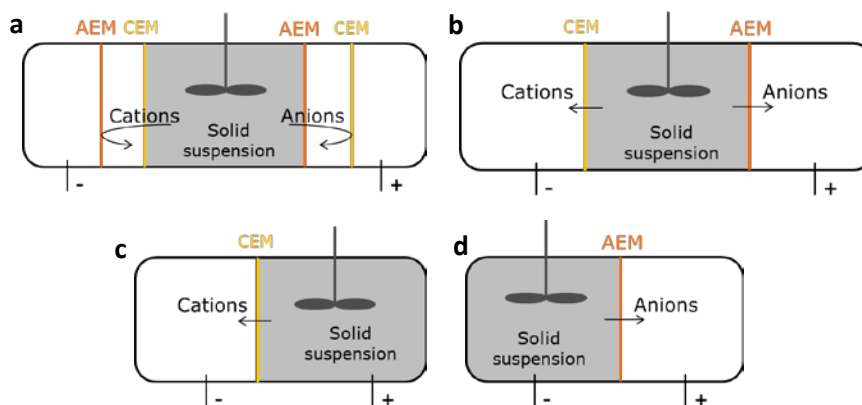

Fig. 5. 5-compartment (a), 3-compartment (b) and 2C ED (c and d) cells [49-53].

1.4.2 Knowledge gaps

These ED setups have been used to treat different matrices like HM-polluted soils and harbour sediments, MSW APC residues and FA, sewage sludge, bioashes as well as incineration SSAs [49-60]. In each case, the objectives can vary. Thus, for soils, harbour sediments and MSW APC residues and FA the aim has been the removal of HM [49-51, 60]. For MSW residues, a focus has been also put in the reduction of salts and HM leaching, since the HM content is higher than in polluted soils, and removal rates for HMs are generally below 5% with a 2C ED cell [59]. Regarding sewage sludge, bioashes and incineration SSAs, the main interest has been the removal of HMs and/or the recovery of nutrients like P [52-59]. No previous research has focused on the ED treatment of gasification SSAs. The main focus of this PhD thesis has been the ED separation of P from HM in Pyroneer SSAs, and it is presented in Papers I, II and III.

In parallel to the investigation on different materials and the number of compartments used in the ED cell, several other operational variables have been studied. These included liquid-to-solid ratio (L/S) in the suspension, current intensity or the use of acid in the suspension [49, 51, 61, 62]. A knowledge gap is, however, the influence of different membrane brands in the ED treatment of HM-polluted matrices. A study comparing the use of different IEM brands to reduce the leachability of HM in MSW APC residues and FA is presented in paper IV.

1.4.3 Parameters in the solid suspension affecting the overall ED performance

ED separation of elements like P or HMs from a solid suspension is a complex process. Fig. 6 shows the influences of relevant parameters to others, and to the most important outcomes for practical purposes: element separation and its electrical energy consumption. Apart from the ED configuration variables (L/S, current intensity, etc.), a key parameter is the change of pH in the solid suspension. Changes in pH values can trigger the solubilisation of most elements from the matrix to be treated, which allows their electromigration; it can also involve the precipitation of new phases like hydroxides at high pH. At the same

time, OH^- and especially H^+ exhibit a higher ionic mobility under the effect of an electrical current than most species [63]; high/low pH during ED leads to higher conductivity of the suspension but also to higher mobilisation of protons and hydroxides to the detriment of the species of interest (P and metals). Consequently, the efficiency (η) of the ED method to transport ionic species can be estimated as the sum of the transport numbers of all species migrating through the membrane except for protons and hydroxides, as they are not the targeted ions to separate:

$$\eta = \frac{(\sum z_i \cdot \Delta n_i) \cdot F}{I \cdot t}$$

where Δn_i is the number of moles of each studied element (i) migrated to another compartment, z_i is its valence and F the Faraday constant (96,485 C/mol). The higher this efficiency is the lower the energy required to transport the ions of interest from the solid suspension to the other compartments.

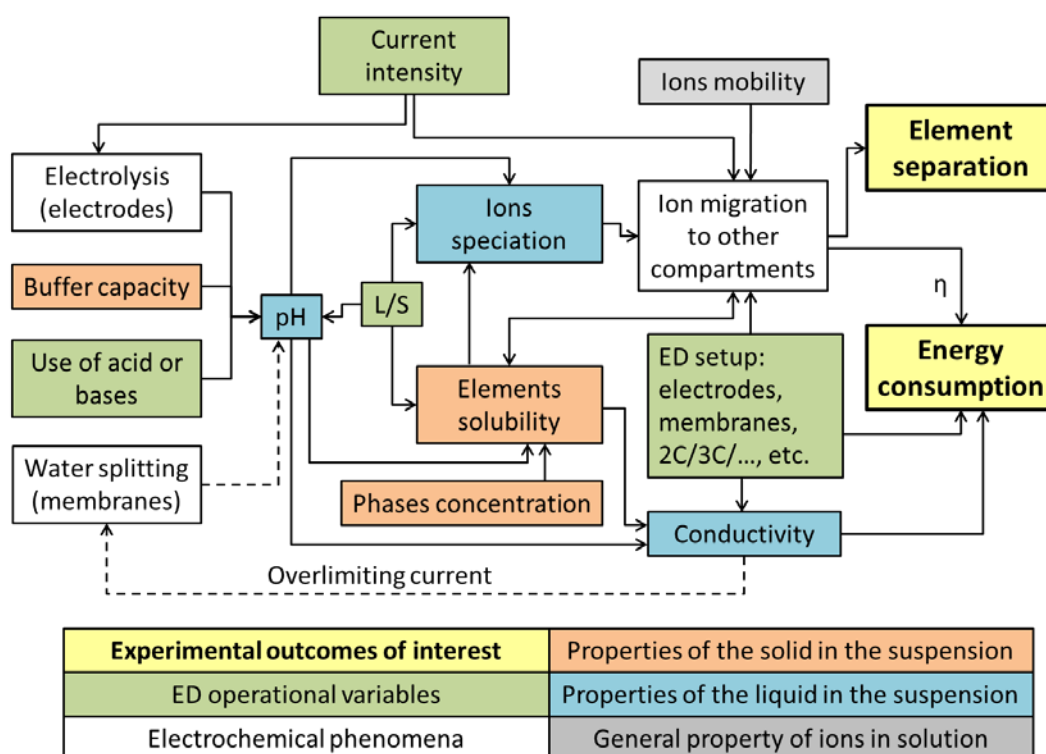

Fig. 6. Influences among the different solid suspension parameters during ED.

Besides pH, element solubility and speciation of ions have also an important role in the ED process. Higher ion dissolution from the solid material, in addition to make possible its electromigration, entails a higher conductivity of the suspension, which reduces the electrical energy demand. At the same time, ion migration enhances the solubilisation of the elements from the matrices through equilibrium displacement. The solubility of each element is also dependent on the phase in which it is found, as it can be observed for Al, Ca and Fe(III) phosphates (Fig. 3). Both pH and element release influence also the speciation of the ions.

For instance, Pb is likely to form neutral complexes with anions like chlorides or sulphates at neutral to acidic pH, whereas negatively charged complexes with carbonates or hydroxides can dominate at pH>11 (Fig. 7). Similarly, P can form complexes with Al, Fe and Ca at acidic pH, which complicates P recovery, but not at alkaline pH. Speciation simulations using Visual MINTEQ 3.0 with these four elements at acidic and alkaline pH are presented in chapter 1.5.

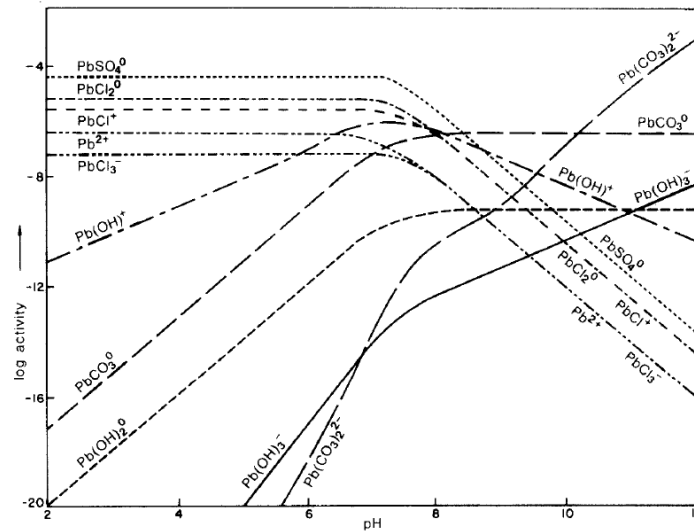

Fig.7. Activity of Pb ionic species at equilibrium with $a_{Cl}=1$, $a_{SO_4}=0.1$ and $f_{CO_2}=10^{-3.5}$ [64].

1.5 Visual MINTEQ simulations

Simulations with Visual MINTEQ 3.0 were performed to better understand P speciation and solubility at acidic and alkaline solutions with Al, Ca and Fe (Tables 4.1-4.4). The concentration of P (0.1 molal, ~3 g P/L) and pH values (2 and 12) selected were similar to the experimental results from papers I, II and III. The concentration of the cationic metals was selected according to their charge equivalence to PO_4^{3-} anion. No possible precipitation of solid phases was specified in MINTEQ, as the aim was to understand the ionic species that could form.

Tables 4.1-4.4: Visual MINTEQ 3.0 simulations with Al, Fe, Ca and PO_4 concentrations.

| Ions | Concentration (molal) | pH | Major species in solution |
|-------------|-----------------------|-------|---|
| PO_4^{3-} | 0.1 | 2.0 | $AlHPO_4^+$ 27.7%, $Al_2PO_4^{3+}$ 9.9%, $H_2PO_4^-$ 31.9%, H_3PO_4 30.5% |
| | | 12.0 | PO_4^{3-} 67%, HPO_4^{2-} 33% |
| Al^{3+} | 0.1 | 2.0 | Al^{3+} 52.5%, $AlHPO_4^+$ 27.7%, $Al_2PO_4^{3+}$ 19.8% |
| | | 12.0* | $Al(OH)_4^-$ 100% |

*Saturation indexes indicate possible Al precipitation as $Al(OH)_3$

| Ions | Concentration (molal) | pH | Major species in solution |
|--------------------|-----------------------|-------|--|
| PO_4^{3-} | 0.1 | 2.0* | $\text{FeH}_2\text{PO}_4^{2+}$ 42.8%, FeHPO_4^+ 51.6%, H_2PO_4^- 2.7%, H_3PO_4 2.8% |
| | | 12.0 | PO_4^{3-} 67%, HPO_4^{2-} 33% |
| Fe^{3+} | 0.1 | 2.0* | Fe^{3+} 4.2%, $\text{FeH}_2\text{PO}_4^{2+}$ 42.8%, FeHPO_4^+ 51.6%, FeOH^{2+} 1.0% |
| | | 12.0* | $\text{Fe}(\text{OH})_4^-$ 100% |

*Saturation indexes indicate possible Fe(III) and P precipitation as Fe(III)-phosphates (at pH 2) and $\text{Fe}(\text{OH})_3$ (at pH 12)

| Ions | Concentration (molal) | pH | Major species in solution |
|--------------------|-----------------------|-------|---|
| PO_4^{3-} | 0.1 | 2.0 | $\text{FeH}_2\text{PO}_4^+$ 83.9%, H_2PO_4^- 8.0%, H_3PO_4 8.1% |
| | | 12.0* | PO_4^{3-} 66.9%, HPO_4^{2-} 33.1% |
| Fe^{2+} | 0.15 | 2.0 | Fe^{2+} 44.1%, $\text{FeH}_2\text{PO}_4^+$ 55.9% |
| | | 12.0* | $\text{Fe}(\text{OH})^+$ 0.4%, $\text{Fe}(\text{OH})_2$ 2.0%, $\text{Fe}(\text{OH})_3^-$ 97.6% |

*Saturation indexes indicate possible Fe(II) and P precipitation as $\text{Fe}(\text{OH})_2$ and Fe(II)-phosphates

| Ions | Concentration (molal) | pH | Major species in solution |
|--------------------|-----------------------|-------|---|
| PO_4^{3-} | 0.1 | 2.0 | $\text{CaH}_2\text{PO}_4^+$ 28.7%, H_2PO_4^- 36.2%, H_3PO_4 35.1% |
| | | 12.0* | CaPO_4^- 99.9% |
| Ca^{2+} | 0.15 | 2.0 | Ca^{2+} 80.9%, $\text{CaH}_2\text{PO}_4^+$ 19.1% |
| | | 12.0* | Ca^{2+} 30.7%, CaPO_4^- 66.6%, CaOH^+ 2.7% |

*Saturation indexes indicate possible Ca and P precipitation as Ca-phosphates

2. SSA characterization

This chapter discusses some of the most important characteristics of the studied SSAs, including the mineralogy, the concentration of several elements and their leachability at acidic and alkaline pH. The aim is to give an overview of the key features deciding the upgrade of the fertilizer value of Pyreoner ashes, with focus on the separation of P from HMs from each ash. In total four different SSAs were studied in this thesis, produced from sewage sludge collected at three different WWTP (Table 5). One of the SSAs (Stegholdt SSA) was the product of co-gasification of biologically precipitated sewage sludge and wheat straw with the Pyreoner gasifier. Two SSAs originated from the Pyreoner gasification of two sewage sludge partially precipitated with Al and/or Fe(III) salts (Randers SSA and Pyreoner Bjergmarken SSA). Finally, one of the sewage sludge partially precipitated with Fe(III) was also incinerated to produce the fourth investigated SSA (incineration Bjergmarken SSA).

Table 5. Summary of the SSAs investigated

| Name | WWTP of origin | P precipitation method (supplied by the WWTP) | Thermal treatment | Feedstock description | Papers |
|------------------------------|----------------|--|-----------------------|--|----------|
| Stegholdt SSA | Stegholdt | Biological. FeCl ₃ used to support sedimentation of sludge | | Dewatered sewage sludge(30%)+wheat straw pellets (70%) | I |
| Randers SSA | Randers | 50% Chemical (FeCl ₃ , AlCl ₃)/50% Biological | Pyreoner gasification | Dried sewage sludge | I and II |
| Pyreoner Bjergmarken SSA | Bjergmarken | 30% Chemical (FeClSO ₄)/70% Biological. AlCl ₃ used as flocculant | | Dried sewage sludge | III |
| Incineration Bjergmarken SSA | | | Incineration at 840°C | Dewatered sewage sludge | |

2.1 Element concentration

Waste ashes are inherently inhomogeneous. For this reason, different batches of around 200-300 g of SSA were made to perform the different experiments. The concentration of one batch for each SSA, selected from Papers I, II, and III, can be seen in Table 6, and show a high variability for some ashes and elements. Therefore, all results must be analysed cautiously.

Concentration of common elements like Al, Ca, P and most HMs was considerably lower in Stegholdt and Randers SSAs in comparison to Bjergmarken SSAs (Table 6) and other SSAs investigated in previous studies. The reason was the high presence of sand in Stegholdt and Randers SSAs, probably from the Pyreoner process, as well as the dissolution effect of the co-gasification with wheat straw in the latter as discussed in Paper I. In Paper III it was seen that incineration Bjergmarken SSA concentrations were similar to the

average values found in German incineration SSAs, whereas Pyroneer Bjergmarken SSA values were in the range of other gasification SSAs found in literature. The most important exception was Fe, which was a bit lower than average values. Al concentration in incineration Bjergmarken SSA was lower than for Pyroneer Bjergmarken SSA, even though they were produced with sewage sludge from the same WWTP. The reason is, as explained in paper III, the variable dosing of AlCl_3 flocculant during the days the sewage sludge was collected. Fe content in Randers SSA was around the same as Bjergmarken SSAs, even though the P content was three times lower, and suggests that a much higher proportion of Fe salts than specified in Table 5 were used in the former. More specifically, Fe/P molar ratio was around 1 for Randers SSA (the same than FePO_4) and around 0.4 for Pyroneer Bjergmarken SSA. For all ashes, the ratio $(\text{Fe}_2\text{O}_3 + \text{Al}_2\text{O}_3)/\text{P}_2\text{O}_5$ was clearly higher than 0.1, which prevents the separation of P using the same acid route as for P-rock [20]. The concentrations of Al, Ca and Fe in relation to P do not bring enough information to predict the suitability of SSAs as a fertilizer. For this reason, a study of the compounds in SSAs, and P leachability at different pH values is presented in chapters 2.2 and 2.3.

In order to understand the chances for recycling these ashes directly into farming, Danish legislation limits for sewage sludge and bioash usage in agriculture are also shown in Table 6. None of them are specific for SSAs, but give an idea about the level of HM content in the studied ashes. As it can be seen, most HMs were on average around or below the legal limits for either sewage sludge or bioash use in agriculture, except for Pb in Bjergmarken SSA.

Table 6. Element concentration (average±standard deviation) in the four studied SSAs. For each ash, one batch was selected. The results are compared with the limits found in Danish legislation. Values exceeding any of the legal limits are shown in bold.

| Element | SSA | | | | Sewage sludge legislation [65] | Bioashes legislation [66] | Units |
|---------|---------------------|--------------------|----------------------------------|--------------------------------------|--------------------------------|---------------------------|-------|
| | Stegholdt (Paper I) | Randers (Paper II) | Pyroneer Bjergmarken (Paper III) | Incineration Bjergmarken (Paper III) | | | |
| Al | 3.1±0.1 | 10.5±1.2 | 51.2±1.1 | 28.3±4.4 | - | - | g/kg |
| Ca | 35.3±3.7 | 34.3±4.4 | 135±27 | 132±47 | - | - | g/kg |
| Fe | 6.2±0.7 | 58.3±6.7 | 61±1.8 | 63.2±13 | - | - | g/kg |
| P | 18.6±1.8 | 30.0±3.6 | 96.0±15 | 88.4±21 | - | - | g/kg |
| Cd | <2.0* | <2.0* | <2.0*-3.6 | 4.19±2.8 | 0.80 | 5** | mg/kg |
| Cr | 19±1.6 | 34.8±3.3 | 89.2±7.4 | 57.7±4.3 | 100 | 100 | mg/kg |
| Cu | 32±1.8 | 165±16.2 | 479±31 | 588±43 | 1,000 | - | mg/kg |
| Ni | 60±4.4 | 30.1±3.1 | 57.9±9.7 | 58.1±3.7 | 30 | 60 | mg/kg |
| Pb | 4.6±0.7 | 40.5±4.2 | 137±87 | 208±100 | 120 | 120** | mg/kg |
| Zn | 140±8.1 | 1,000±109 | 1,650±250 | 2,120±230 | 4,000 | - | mg/kg |

*Below ICP-OES Limit of detection (LOD), ** Most restrictive values

The ratios of the trace elements to P are calculated in Table 7 for the four SSAs. All ratios were below the legal limits for sewage sludge, except for Ni/P for Stegholdt SSA. However, most HM/P were clearly higher in the SSAs than in commercial fertilizers, with the exception of Cd and Cr. Thus, there is a necessity to reduce the HM/P to upgrade the fertilizer value of the nutrients in Pyroneer and incineration SSAs.

Table 7. HM/P in the four studied SSAs, calculated from average values from Table 6 in mg/kg P. The results are compared with the limits found in Danish legislation and the concentrations found in commercial fertilizers (including DAP, MAP and several NPK). Values exceeding the legal limits are shown in bold.

| Element | SSA | | | | Sewage sludge legislation [65] | Commercial fertilizers [25, 26] |
|---------|---------------------|--------------------|----------------------------------|--------------------------------------|--------------------------------|---------------------------------|
| | Stegholdt (Paper I) | Randers (Paper II) | Pyroneer Bjergmarken (Paper III) | Incineration Bjergmarken (Paper III) | | |
| Cd | <107.5* | <67* | <21*-38 | 47 | 100 | 11-60 |
| Cr | 1,010 | 1,160 | 929 | 653 | - | 125-794 |
| Cu | 1,710 | 5,490 | 4,990 | 6,650 | - | 7-80 |
| Ni | 3,230 | 1,000 | 603 | 657 | 2,500 | 8-168 |
| Pb | 245 | 1,350 | 1,430 | 2,350 | 10,000 | 9-72 |
| Zn | 7,700 | 33,400 | 17,200 | 24,000 | - | 131-1,080 |

*Below ICP-OES LOD

2.2 Compounds in the SSA

A critical feature in the SSAs is the phosphate compounds present, which eventually determine its plant availability as described in chapter 1.3.3. The solid phases present in ashes can be characterised with different techniques. A common one is the use of XRPD, although it is limited to identify crystalline phases. Few minerals were found in the XRPD of Stegholdt SSA (SiO_2 and KCl) and Randers SSA (SiO_2), and no P-compounds were identified, probably due to the high content C and/or of sand (paper I). In contrast, more mineral phases were found for Bjergmarken SSAs: quartz (SiO_2) and calcium phosphates ($\text{Ca}_9\text{Fe}(\text{PO}_4)_7$, $\text{Ca}_9\text{Al}(\text{PO}_4)_7$ and/or $\text{Ca}_7\text{Mg}(\text{PO}_4)_6$) for incineration and Pyroneer Bjergmarken SSA, as well as hematite (Fe_2O_3) and anhydrite (CaSO_4) for incineration Bjergmarken SSA (Paper III). No major presence of Fe- or Al-phosphates was identified in the XRPD spectra. A reason can be that they are found in amorphous phases, as previously identified for gasification SSAs in other researches [40].

A fact that can help understanding the P-compounds present in SSAs is the minerals in which iron is found. As explained in chapter 1.3.3, Fe-rich incineration SSAs traditionally have a red tone related to the hematite formation from iron phosphates during the thermal process, which was observed for incineration Bjergmarken SSA (Fig. 8a). Since no hematite or red colour was identified in Pyroneer Bjergmarken SSA (Fig. 8b), Fe (III)-phosphates, which can be assumed to form in Bjergmarken sewage sludge, can be expected to remain after the gasification. Both Stegholdt and Randers SSAs did not present a red colour or hematite, but a dark colour similar to Pyroneer Bjergmarken SSA. This can indicate the persistence of Fe(III)-phosphates for Randers SSA but not for Stegholdt SSA, as the Fe/P ratio is 5.5 times lower than the one of FePO_4 (calculated from Table 6).



Fig. 8: Incineration (a) and Pyroneer (b) Bjergmarken SSAs.

Another approach to identify the compounds present in SSAs could be the use of a SEM-EDX mapping. Using this technique, minor areas where Al, Fe and P were more concentrated than the rest of elements were identified in Bjergmarken Pyroneer SSA. This reinforces the argument of the presence of Fe(III)-phosphates, and possibly Al-phosphates, although it does not estimate their proportion in relation to all P bindings. The mapping of most of these and the other three SSAs did not present areas where Al, Ca or Fe dominated, and thus it could neither confirm the existing data nor bring new information.

2.3 pH solubility of the elements

In paper I it was found that P in Stegholdt SSA could be completely extracted with an acid leaching, and separated from Al and Fe, because its solubility was mostly influenced by Ca. Therefore, no further solubility investigation was performed in order to separate P from the bulk ashes for these SSA. For Randers and Bjergmarken SSA, with higher Al/P and Fe/P (chapter 2.1), the solubility of the different elements as a function of acid and alkaline pH was studied in Papers I, II and III so as to define the strategy to recover P from these SSAs. Leaching tests of SSAs with acid and bases can bring, in turn, a verification of the existence, and/or an idea of the predominance, of each P-binding (Ca- or Al/Fe(III)-P). Consequently, the solubility of the different elements was investigated in leaching tests using NaOH and HNO₃ at different concentrations, as well as de-ionised water. Fig. 9 shows the results for Randers and Bjergmarken SSA for Al, Ca, Fe and P after 7 days, with de-ionised water, and HNO₃/NaOH at 0.1, 0.3, 0.5, 0.7 and 1 M in duplicates at L/S=10.

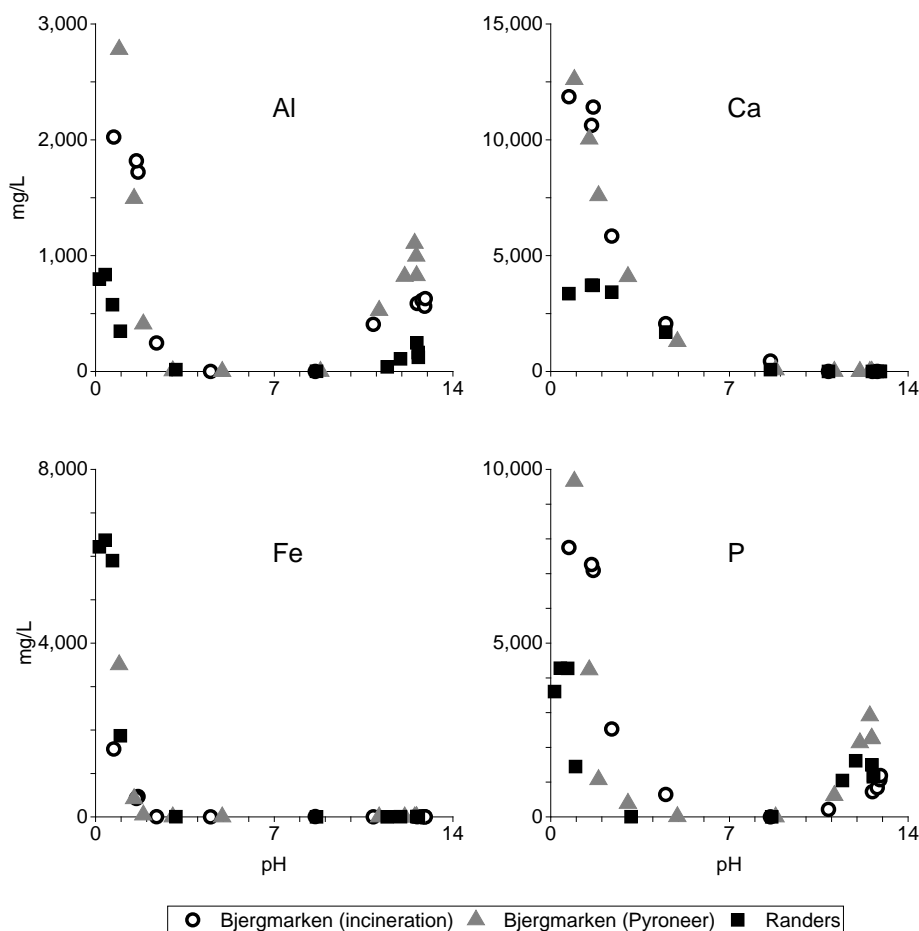

Fig. 9. Concentrations (average) of Al, Ca, Fe and P in the leachates at different pH values for Randers and Bjergmarken SSAs for 7 days.

The solubility curve of P, Al and As for all SSAs, and Ni for all Pyroneer SSAs, was following a similar pattern: the minimum value was found at around neutral pH, with increasing solubility as pH increased or decreased, making a u-shape as for Al and P in Fig. 9. The solubility of most of the other elements (except Na and K), similarly to Fe and Ca in Fig. 9, increased with the decrease of pH, being insoluble at neutral to high pH. Thus, most metals dissolved simultaneously with P in acidic medium, where above 80% of P can be extracted (papers I and III). In addition to that, P solubility at acidic pH in Randers and Pyroneer Bjergmarken was generally lower than in incineration Bjergmarken SSA due to a higher influence of Al/Fe(III) in chemically precipitated Pyroneer SSAs (chapter 2.2 and papers I and III). Moreover, as explained in chapters 1.3.3 and 2.2, acid-insoluble hematite is produced from Fe-phosphates during sewage sludge incineration; consequently, Fe solubilisation at acidic pH for incineration Bjergmarken SSA was considerably lower than for Pyroneer Bjergmarken SSA (Fig. 9). In either case, P-separation from both metals is hindered due to the formation of Al/Fe-P complexes once solubilised (chapters 1.3.3 and 1.5). An alternative could be the extraction of P at high pH, which would lead to a solution relatively cleaner of most metals. However, alkaline leachability of P tended to be lower than in acidic pH (Fig. 9), and eventually a lower P-extraction rate was achieved: up to 52% for Randers, 30% for Pyroneer Bjergmarken and 13% for incineration Bjergmarken SSA (calculated from Fig. 9 and Table 7). Thus, a separation of most P from most metals cannot be done in a single acid or alkaline leaching step.

P solubilisation in alkaline medium proves a significant existence of Al/Fe(III)-P bindings in these three SSAs, as Ca- and Fe(II)- phosphates are insoluble at high pH (Fig. 3 and chapter 1.5). Furthermore, the higher concentration of P in the alkaline leachates Pyroneer than in incineration SSA (Fig. 9), at similar pH, confirms a higher presence of these bindings in Pyroneer SSAs, due to the use of less oxygen in the thermal process (chapter 1.3.3). At the same time, the maximum extraction rate achieved at high pH for Pyroneer SSAs (see previous paragraph) is consistent with the % of P captured chemically in each SSA (Table 5). However, the % of P bound to each metal (Al/Fe(III) or Ca) cannot be quantified accurately in an alkaline extraction, since solubilised P can bind to Ca-compounds or re-precipitate as Ca-P [41, 43-45] and the studied SSAs are intrinsically inhomogeneous (chapter 2.1).

2.4 Acid-alkaline extraction of P

An alternative to single acid or alkaline P-extraction steps could be the use of a two-stage process combining them with a filtration step in between to separate the bulk ash. Such procedure has already been used to separate P from Al-precipitated incineration SSAs, soils or MSW FA [31, 41, 43, 45]. In paper II, two 2-stage alternatives were investigated for Randers SSA (acid-alkaline and alkaline-acid at L/S=5), and the results are conceptually presented in Fig. 10. P extraction was maximized in an acid leaching step, where Ca-P bindings were solubilised and Ca was removed, followed by an alkaline one, where Al/Fe(III)-P bindings were solubilised. This order should also allow a separation of P from Fe and the majority of HMs, since most metals were insoluble at high pH for Randers and Bjergmarken SSA (chapter 2.2).

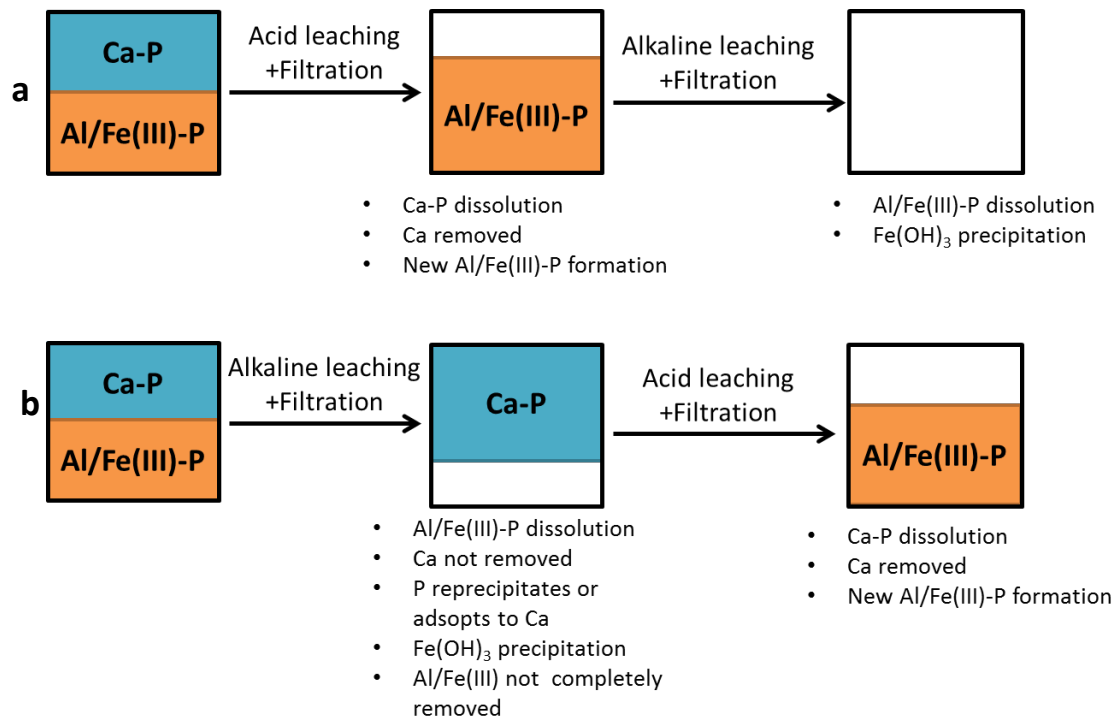

Fig. 10. Dissolution and formation of P-bindings in SSAs in the two-stage acid-alkaline (a) and alkaline-acid extraction (b) of P. Drawing made based on the explanations given in paper II.

The results of the acid-alkaline extraction of Randers SSA from paper II are shown in Table 8. It should be noted that the concentrations of most elements in the ash batch used for this extraction were higher than the concentrations in Table 6. For instance, average concentration of P was around 1.6 times higher. Nevertheless, the result showed a P-concentration in the leachate of the second stage (6,400 mg/L, L/S=5) which was four times higher than in the single alkaline extraction (1,600 mg/L at L/S=10, Fig. 9), and represented 73% and 52% P-extraction (chapter 2.3), respectively. There are two explanations for this apparent increase of % P leached in the two-stage extraction process. First, as mentioned in chapter 1.3.3 and in Fig. 10, the formation of new alkaline-soluble Al/Fe(III)-P bindings from P and Fe(III) dissolved during the acid stage, similarly to what was suggested for Al-precipitated incineration SSAs [41]. In that same research it was seen that new formed Al-P were not detectable in x-ray diffraction [41], and thus their formation cannot be confirmed by this method. Second, the high solubilisation of Ca in the acid stage can prevent its interference in P solubility in the alkaline stage (chapters 1.3.3 and 2.3 and Fig. 10b).

The same process was applied to both Bjergmarken SSAs, but at L/S=10, with a lower acid concentration and in duplicates. HNO₃ concentrations (0.3 M) were selected according to the acid leaching tests (Fig. 9), in order to minimize the leaching of Fe but allow the leaching of some Ca. The rate of total P extraction (calculated from Tables 6 and 8) was low: 45% for the Pyroneer and 57% for incineration Bjergmarken SSAs. However, the results can be used as an orientation. In these two ashes, the concentration of P in the leachate of the second stage was higher than in the direct alkaline leaching. For incineration Bjergmarken SSA it increased from 1,200 (Fig. 9) to 2,100 mg/L (Table 8), whereas for Pyroneer Bjergmarken SSA it increased from 2,900 (Fig. 9) to 3,900 mg/L (Table 8). Similarly to Randers SSA, new Al/Fe(III)-P bindings can also be formed in Bjergmarken SSAs during the acid stage and/or Ca removal in the same stage can avoid P to bind to Ca-compounds or to form new Ca-phosphates during the alkaline stage. At the same time, P was effectively separated from Fe (but not Al) in the leachates of these three SSAs (Table 8), due to the precipitation of Fe(OH)₃, in contrast to a direct acid leaching (Fig. 9).

Table 8. Concentrations (average±standard deviation) in the leachates (mg/L) in the stages of the acid-alkaline extractions.

| Element | Randers SSA (paper II) | | Pyroneer Bjergmarken SSA | | Incineration Bjergmarken SSA | |
|----------|------------------------|------------|--------------------------|------------|------------------------------|------------|
| | Acid | Alkaline | Acid | Alkaline | Acid | Alkaline |
| L/S | 5 | 5 | 10 | 10 | 10 | 10 |
| Chemical | 0.5 M HNO ₃ | 0.5 M NaOH | 0.3 M HNO ₃ | 0.5 M NaOH | 0.3 M HNO ₃ | 0.5 M NaOH |
| pH | 1.5 | 11.7 | 2.9 | 12.7 | 2.5 | 12.8 |
| Al | 470 | 0.98 | 14±1.0 | 1,400±7.2 | 290±24 | 1,000±95 |
| Ca | 12,000 | 0.29 | 4,700±19 | 0.44±0.28 | 6,100±90 | 1.90±1.3 |
| Fe | 2,700 | 0.44 | 0.99±0.10 | 0.72±0.54 | 2.90±0.37 | 0.65±0.42 |
| P | 3,300 | 6,400 | 380±16 | 3,900±9.6 | 2,900±19 | 2,100±210 |

3. Electrodelectrolytic remediation of SSAs

3.1 Setups investigated

As a first priority of the research, the ED experiments focused on maximizing P extraction from the SSAs. The different ED setups used in this research for the four SSAs, and the reasons that motivated their research, are included in Fig. 11. As explained in papers I, II and III, the first setup used to treat all SSAs was a 2C ED cell with a CEM (chapter 1.4.1 and Fig. 5c), since it was earlier proved to be suitable for P separation from HMs in Fe-rich incineration SSAs [52, 62, 67], and most P could be extracted at acidic pH (chapter 2.3). All experiments were carried at the same conditions, varying only the remediation time (Table 9); in paper II such time variation was done in parallel with the achievement of a certain pH at the suspension with Randers SSA. These conditions were chosen according to the previous studies on incineration SSAs [52, 62]. The product of ED P-separation was an acidic solution at the anolyte, which was rich in P and depleted in Al, Fe or most HMs in comparison to the original SSA. Thus, it consisted mainly in an H_3PO_4 aqueous solution, which could potentially be further processed in the fertilizer industry if concentrated, as it is currently done with WPA (chapter 1.3.1). In chapter 3.2, the quality of the anolyte is explored in more detail. The separation of P and metals in a 2C ED cell was achieved thanks to the acidification of the SSA suspensions (chapter 1.4.1) together with the migration of most metallic cations to the cathode, as well as a proportionally lower solubilisation of most HMs than P in from SSAs in acidic pH as seen in papers I and III.

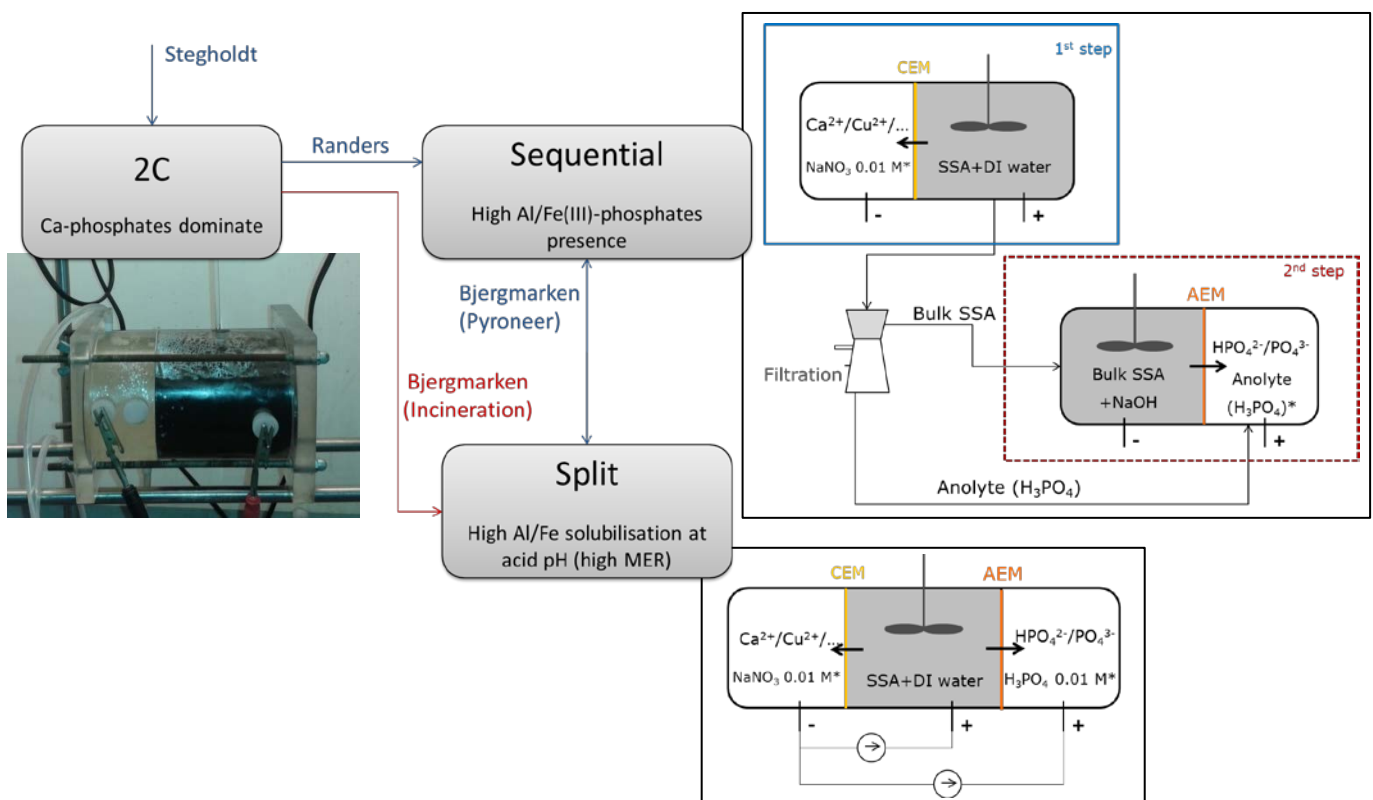

Fig. 11. ED setups used in the present research (papers I, II and III) and their motivation. *Initial solutions.

Table 9. Conditions of the 2C ED cell experiments in papers I, II and III.

| | |
|---------------------|---|
| Intensity | 50 mA |
| L/S (anolyte) | 10 (35 g of SSA+350 mL DI water) |
| Catholyte solution | NaNO ₃ 0.01 M (pH<2 adjusted with HNO ₃) |
| Electrodes | Platinum coated titanium wire Permascand® |
| Membrane area/brand | 50 cm ² /Ionics |
| Remediation time | 1-9 days (depending on the SSA) |

For Stegholdt and incineration Bjerghmarken SSAs, the maximum P recovery in the anolyte of a 2C ED cell was above 80% (Fig. 12). These results are comparable with the previous ones in literature, where above 80% of P was recovered in a 2C ED cell from Fe-rich incineration SSA [52, 62, 67]. For Randers and Pyrener Bjerghmarken SSAs the recovery was limited to 26 and 40%, mainly due to a higher presence of Al/Fe(III)-P bindings, which have low solubility at acidic pH (chapter 2.3). By increasing remediation times in a single 2C ED cell, no substantial gains were achieved for these two SSAs; in addition, it generally increased the MER of the anolytes obtained (Fig. 12) and the amount of P migrated to the cathode compartment, probably due to the formation of Al/Ca/Fe-P complexes (papers I and III and chapter 1.5).

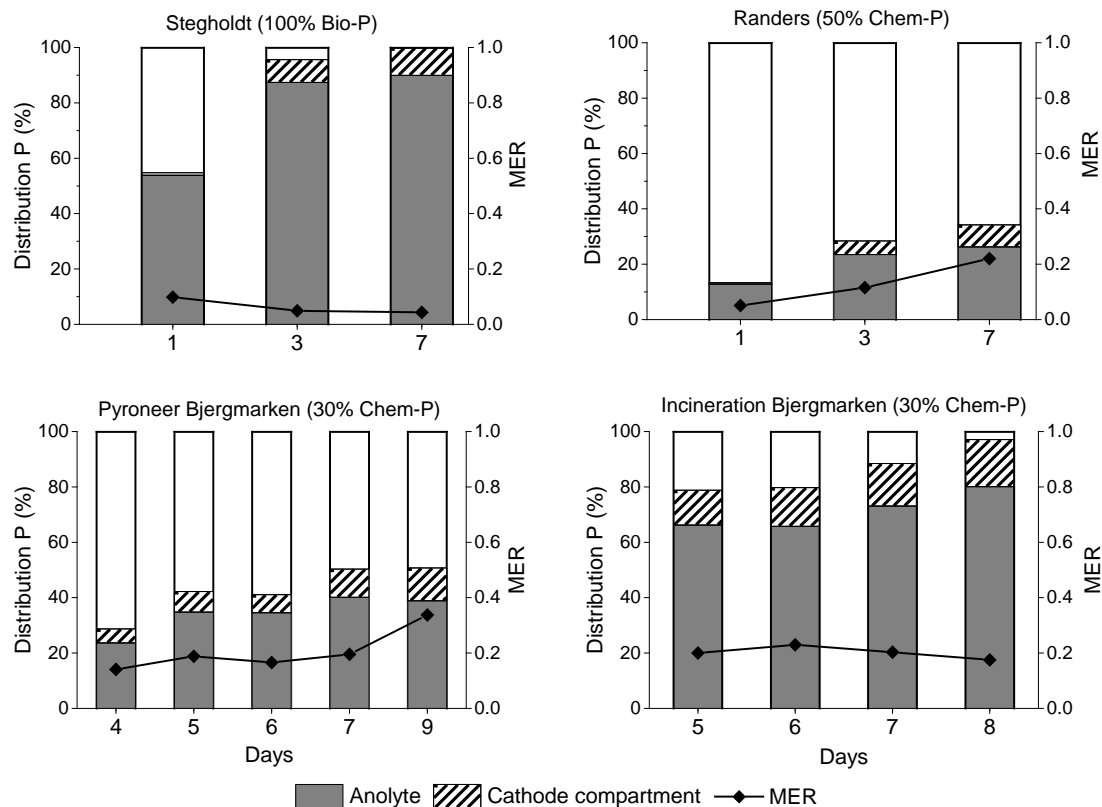

Fig. 12. P distribution in the anolyte and cathode compartment (%) using 2C ED cell in the four studied SSAs. Data from experiments presented in papers I and III.

In order to increase P recovery for Randers and Pyroneer Bjergmarken SSAs, a new setup was used which combined sequentially two separate 2C ED cells (“Sequential” in Fig. 11). It was first presented in paper II for Randers SSA, and used again for Pyroneer Bjergmarken SSA in paper III. The idea behind this new process was to carry an ED sequential process in which the SSAs were acidified in the anolyte of a first step and subsequently alkalised in the catholyte of a second step, similarly to the acid-alkaline P-extraction presented in chapter 2.4. In the 2nd step, alkaline soluble Al/Fe(III)-P dissolve, no positive metallic-P complexes are formed, and P migrates towards the anode compartment, where the anolyte resulting from the 1st step is placed. The time of the 2nd step was fixed to 3 days for Randers SSA and to 5 days for Pyroneer Bjergmarken SSA. An international patent application has been filed for this setup (publication V). With the sequential setup, up to ~70% of P was recovered for Randers and Pyroneer Bjergmarken SSA (Fig. 13). The recovery rates were higher in the sequential setup than in a single 2C ED cell for the same remediation time. For instance, for Randers SSA up to 70% of P was recovered in a sequential treatment that lasted 124.5 hours (52.5 in the 1st+ 72 in the 2nd step), well above the 23% achieved in a single 2C ED cell for 125 hours (Fig. 12). For Pyroneer Bjergmarken SSA, 63% of P was recovered in the sequential setup lasting 9 days (4+5 days, Fig. 13), whereas the recovery in a single 2C ED cell was 39% for the same duration (Fig. 9). In addition, the MER values achieved for Randers SSA were below 0.085 (Fig. 13), the technical limit for the production of DAP (chapter 1.3.2). For Bjergmarken SSAs, MER values were above this limit using a 2C ED cell (Incineration Bjergmarken, Fig. 12) or a 2C ED sequential setup (Pyroneer Bjergmarken, 4-6 days, Fig. 13).

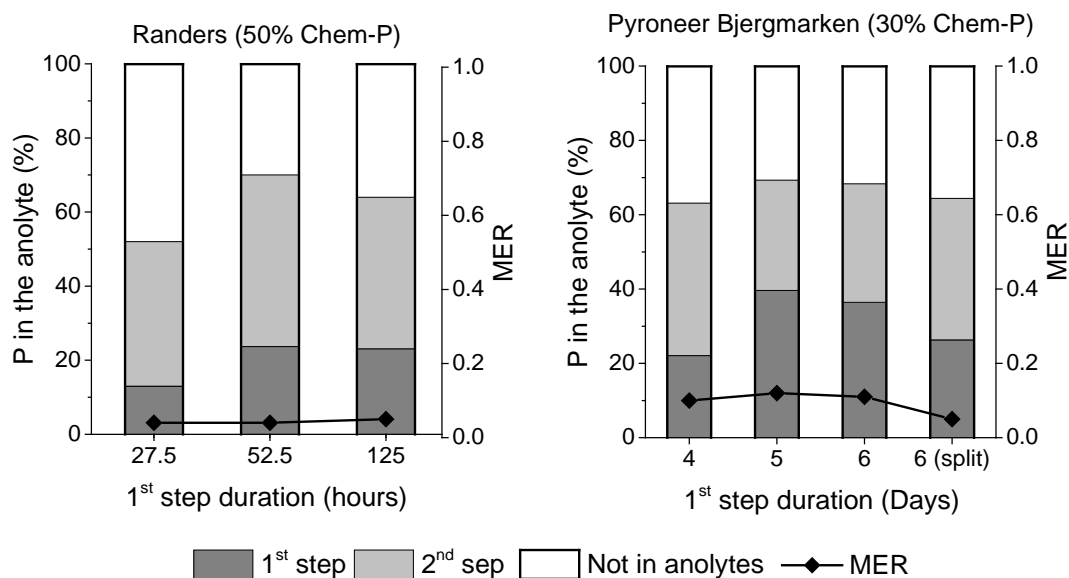

Fig. 13. P recovered (%) and MER in each anolyte using the sequential ED setups for Randers and Pyroneer Bjergmarken SSAs. Data from experiments presented in papers II and III.

In order to improve MER results for both Bjergmarken SSAs, a new setup where two anodes in two separate compartments connected to a cathode was used ("Split" in Fig. 11), and it is presented in paper III. The total current applied was equally 50 mA, but only 25 mA was directly applied in the anode compartment with the SSA suspension. For Pyroneer Bjergmarken SSA, a split ED cell was combined with an AEM-containing 2C ED cell following the ED sequential concept (Fig.11). With such setup, the total load of H^+ in the SSA suspension was expected to be lower, with the same amount of cations migrating towards the cathode. Therefore, the amount of Al, Fe and Mg in the anolyte was anticipated to decrease due to lower release. In effect, after using this setup, MER was reduced to 0.05 for Pyroneer (Fig. 13) and to 0.08 for incineration Bjergmarken SSA, due to a lower solubilisation of Al, Fe and Mg (not shown in the figures or tables). An additional benefit of the split setup was the lower HM/P for Cr, Cu and Zn (paper III). However, P-recovery for the incineration SSA was limited to 65% (paper III); the most probable reason could be the shorter period of time (6 days) compared to the experiment where 80% was achieved (8 days, Fig. 12).

3.2 P-liquids produced

The MER and the metal to P ratios (M/P) achieved in the anolytes of some selected experiments are shown in Table 10. M/P in the anolytes of ED remediation (papers I, II and III and Table 10) were clearly below the initial ones in each SSA (calculated from Table 6). The only exception was As/P for Randers SSA and incineration Bjergmarken SSA, which were <67-133 and 129 mg/kg P in the untreated SSAs, respectively. Moreover, most of these ratios were below or in the range of WPA (Table 10). A higher purification can be achieved with additional processes used in the H_3PO_4 industry, like sulphide precipitation or solvent extraction of As and HMs [22]. In general, these methods represent a relatively small economic cost in the overall H_3PO_4 production [22], although its suitability to treat these anolytes requires further study.

Table 10. Parameters in the anolytes of some selected ED experiments, based on maximised % of P recovery and/or minimized MER. M/P higher than in WPA are highlighted in bold. Data from experiments presented in papers I, II and III.

| | SSA | | | | WPA [22] | Units |
|--------------------|-------------------|--|-------------------------|-----------------------------|-------------|---------|
| | Stegholdt | Randers | Pyroneer Bjergmarken | Incineration Bjergmarken | | |
| | Chosen experiment | | | | | |
| | 2C (7 days) | Sequential** (1 st step in 125 hours) | Split sequential | Split*** | | |
| P concentration | 1.4 | 1.7 | 4.4 | 2.3 | ~350-450 | g P/L |
| MER | 0.04 | 0.05 | 0.05 | 0.08 | - | - |
| Al/P | 0.01 | 0.02 | 0.06 | 0.06 | <0.03 | kg/kg P |
| Fe/P | 0.04 | 0.05 | <0.01 | 0.04 | <0.04 | |
| Mg/P | 0.02 | 0.01 | <0.01 | 0.02 | 0.01-0.03 | |
| As/P | <14* | 108 | 34 | 138 | 20-70 | |
| Cd/P | <14* | <11* | 5* | 8 | 120-500 | mg/kg P |
| Cr/P | 36 | 14 | 7 | 64 | 100-3,000 | |
| Cu/P | 44 | 250 | 20 | 845 | 10-400 | |
| Ni/P | 202 | 22 | 61 | 119 | 100-700 | |
| Pb/P | <14* | <11* | 14 | 23 | <4 | |
| Zn/P | 542 | 746 | 35 | 628 | 100-10,000 | |

*Below ICP-OES LOD. **Experiment selected based on the maximum mass of P recovered in paper II.

***Calculated from the values in the two anolytes.

M/P in the anolyte were generally reduced from the 1st to the 2nd step in the sequential ED experiments, because of the insolubility of most metals at high pH (chapter 2.3). However, ratios of As, Al and Ni to P increased in some cases (Table 11), because these elements were alkaline soluble in the studied SSAs (chapter 2.3) and probably formed negatively charged species like AsO_4^{3-} or $\text{Al}(\text{OH})_4^-$ at alkaline pH which can also migrate together with P anions (HPO_4^{2-} and PO_4^{3-}). Pb/P are also included in Table 11 as they increased in one of the experiments for Randers SSA.

Table 11. M/P in the analytes of the ED sequential experiments. In bold, the values that increased from the 1st to the 2nd step. Data from experiments presented in papers II and III.

| Step | Units | SSA | | | | | | | | | | | | | |
|------|---------|--|-----------------|-----------------|-----------------|-----------------|-----------------|---|-----------------|-----------------|-----------------|-----------------|-----------------|-----------------|-----------------|
| | | Randers (1 st step - hours) | | | | | | Pyroneer Bjermarken (1 st step - days) | | | | | | | |
| | | 27.5 | | 52.5 | | 125 | | 4 | | 5 | | 6 | | 6 (split) | |
| | | 1 st | 2 nd | 1 st | 2 nd | 1 st | 2 nd | 1 st | 2 nd | 1 st | 2 nd | 1 st | 2 nd | 1 st | 2 nd |
| Al/P | g/kg P | 19 | 29 | 16 | 24 | 27 | 18 | 104 | 104 | 109 | 104 | 114 | 91 | 0.7 | 60 |
| As/P | | 159 | 116 | <40* | 139 | 94 | 108 | 82 | 64 | 59 | 62 | 61 | 49 | 79 | 34 |
| Ni/P | mg/kg P | 93 | 21 | <40* | <15* | 64 | 22 | 22 | 62 | 39 | 23 | 9 | 6 | 11 | 61 |
| Pb/P | | <79* | <20* | <40* | 48 | <31* | <11* | 13 | 5 | <8* | <4* | 8 | 6 | 33 | 14 |

*Below ICP-OES LOD.

M/P for incineration Bjermarken SSA was generally higher than for Pyroneer Bjermarken SSA, including a higher MER (Table 10 and paper III). This was due to the use of the 2nd step in the latter, but also to a higher solubility of most HMs in incineration Bjermarken SSA than Pyroneer Bjermarken SSA (paper III). As seen in chapter 2.4, some degree of P recovery was possible in the alkaline step of a two-stage extraction. Thus, an adaptation of the sequential setup could be useful also for incineration SSAs to reduce the HM content and MER, but it requires further study.

3.3 Potential further developments

After the ED experiments, some parallel enhancements can make the ED method more attractive from a technological but also economical point of view. The following chapters include guidelines to achieve a higher P recovery, avoid the loss of soluble K, lower the energy consumption, utilize all outputs from ED treatment of SSAs as well as increase the concentration of P in the recovered product (the anolyte).

3.3.1 P recovery in the sequential process

The % of recovered P in the anolyte was limited to around 70% for Randers and Pyroneer Bjermarken SSAs, below the usual values of incineration SSAs (>80%, chapter 3.1 and Fig. 12). A key feature to improve this rate is to understand to which element P is bound after the use of the sequential ED setup. An estimation of alkaline-soluble (Al/Fe(III)-P) and acid-soluble (Ca-P) bonds was made assuming that:

- All Ca left in the bulk SSAs after the 2nd step was bound to P with a molar stoichiometry 3:2 (Ca:P). This implied an overestimation of these bindings, since there could be other Ca compounds not containing P, but it gave an overview of the effectiveness of the sequential ED method to recover P from the different ashes.

- All P not bound to Ca, calculated in the previous point, was bound to Al/Fe(III).

The results (Table 12) show that P is considerably more bound to Ca in the bulk Pyroneer Bjergmarken SSA than in bulk Randers SSA after the sequential ED process. One reason is most probably the higher proportion of Al/Fe(III)-P bindings in the untreated Randers SSA than in the untreated Pyroneer Bjergmarken (chapter 2.3). Another explanation is the use of a higher concentration of NaOH in the 2nd step of Pyroneer Bjergmarken SSA (0.15 M) than Randers SSA (0.026 M), which eases the dissolution of Al/Fe(III)-phosphates: the amount of P solubilised in the 2nd step was between 5.8 and 7.2 mmol/day for Pyroneer Bjergmarken, and between 3.9 and 4.3 mmol/day for Randers SSAs (calculated from the data in papers II and III). Thus, a strategy to increase the recovery in Randers SSA is to use a higher concentration of NaOH in the 2nd step. A possible solution to increase the dissolution of Ca-P bindings in both SSAs is to increase the time of remediation in the 1st step. In effect, Ca solubilisations in a 2C ED cell after 125 hours for Randers, and after 7 and 9 days for Pyroneer Bjergmarken were 86, 89 and 92%, respectively; in contrast Ca solubilisation for shorter periods was between 53 and 81%. A longer experimental time might be combined with a split setup, in order to avoid the solubilisation of Al, Fe, Mg and most HMs (chapter 3.1). In parallel, the reuse of H₃PO₄ or an anolyte solution from a previous experiment can also increase Ca removal in the 1st step.

Table 12. Estimation of P bonds in the bulk SSA after the 2nd step of the ED sequential process, based on data from the experiments in paper II and III.

| | SSA | | | | | | |
|---------------------|--|------|-----|--|-----|-----|-----------|
| | Randers (1 st step - hours) | | | Pyroneer Bjergmarken (1 st step - days) | | | |
| | 27.5 | 52.5 | 125 | 4 | 5 | 6 | 6 (split) |
| Bound to Ca | 60% | 46% | 29% | 81% | 78% | 80% | 80% |
| Bound to Al/Fe(III) | 40% | 54% | 71% | 19% | 22% | 20% | 20% |

3.3.2 K loss during Stegholdt SSA treatment

As mentioned in paper I, during the ED recovery of P from Stegholdt SSA, around 80% of K was lost in the catholyte, since it was found in water-soluble forms like KCl. A possible way to mitigate this loss is to wash the ash with DI water before the ED treatment. To estimate the impact of this pre-treatment, around 50 grams of this SSA was washed with 250 mL of DI water and filtrated at atmospheric pressure, resulting in a 30% K-extraction in a 138 mL of a K-rich solution, and depleted of other elements. The ash, which absorbed the rest of the water, was dried and subsequently treated with a 2C ED cell for 3 days. The voltage evolution during the treatment, which eventually decides the energy consumption, was higher at the beginning in the pre-washed than in the non-washed Stegholdt SSA, but they became similar after 24 hours (Fig. 14). 76% of P was recovered in this experiment, a rate which is similar to comparable results without pre-wash (Fig. 12). These results show that it is technically possible to recover K and P from the SSA with an adequate washing, although it requires further study for optimization.

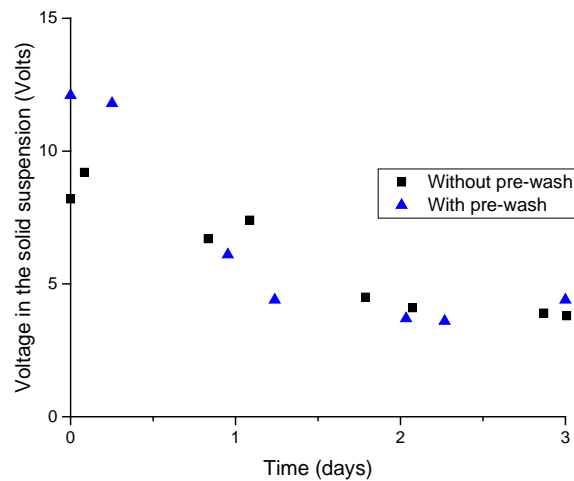

Fig. 14. Voltage evolution of ED treatment of Stegholdt SSA with and without pre-wash.

3.3.3 Energy consumption during ED

An important parameter of the ED treatment of SSA is the electrical energy required to recover P. The power consumed by the direct application of electricity (E) was estimated using the voltage measurements during the experiments:

$$E = I \cdot \sum (t_{i+1} - t_i) \cdot \frac{V(t_{i+1}) + V(t_i)}{2}$$

Where I is intensity and t_i is the time at which the voltage $V(t_i)$ was measured during ED. The efficiency in the use of electricity (η , chapter 1.4.3), was also estimated assuming that:

$$\eta = \frac{(\sum z_i \cdot \Delta n_i) \cdot F}{I \cdot t}$$

- Only counter-ions which migrated through the IEM (anions in AEM and cations in CEM) to the electrolyte in each step are considered, since they are expected to transport almost all current (>0.95) [47].
- In the 1st step, only Ca, Fe and Al migrated to the catholyte are considered, assuming a valence (z_i) of 2 (Ca, Mg) and 3 (Fe and Al). The reason is that these elements have the biggest impact in P recovery. No metallic-P complexes were considered, as the mass of migrated P was at least 15 times lower than Ca, the main metal in the catholyte.
- In the 2nd step, only P migrated to the anolyte is considered, assuming a valence of 3. This implies an overestimation as P can be present as HPO_4^{2-} , but gives an overview of the needs for improvement in the sequential ED process.

Table 13 summarizes these results in kWh per kg of recovered P for ED experiments with Randers SSA from paper II. In order to reduce E, the conductivity of the suspensions could be increased by reusing an anolyte in the 1st step and by increasing NaOH concentration in the 2nd step. Both approaches were tested separately: a 1st step experiment was performed for 3 days (at 50 mA and L/S=10) using the anolyte from the 7-day ED experiment from paper I, and a 2nd step ran for 2 days (at 50 mA, L/S=12, and after another separate 1st step running for 3 days) using a concentration of 0.1 M NaOH instead of the 0.026 M used in paper II.

Table 13. Mass of P recovered, energy consumption (E) per kg of recovered P, and efficiency of ED experiments on Randers SSA.

| Experiment | 1 st step | | | 2 nd step | | | |
|--|--------------------------|--------------------|------------|--------------------------|--------------------|------------|----|
| | mass of recovered P (mg) | kWh/kg recovered P | η (%) | mass of recovered P (mg) | kWh/kg recovered P | η (%) | |
| 1 st step | 27.5 | 126 | 143 | 51 | 339 | 130 | 24 |
| duration | 52.5 | 239 | 93 | 51 | 361 | 120 | 26 |
| (hours) | 125 | 294 | 126 | 26 | 364 | 150 | 26 |
| SSA+anolyte reuse (1 st step) | 239* | 57 | 35 | - | - | - | - |
| SSA+0.1 M NaOH (2 nd step) | - | - | - | 425 | 37 | 46 | |

*Amount corresponding to the increase in the anolyte.

The resulting voltage drops in the ED cell were compared for each step in Fig. 15, showing a clear reduction in both cases. This allowed a reduction in E for both steps, as seen in Table 13, with a comparable mass of recovered P. It has to be taken into account that for the 1st step the lower η (35%) was probably due to an excessively long duration of the experiment, which lead to a much lower pH (1.35) compared to the values from papers I and II. For the 2nd step, both the kWh/kg P and η were improved in a shorter experiment than in paper II (2 instead of 3 days). Thus, optimization of treatment times and concentration of chemicals added in the ED experiments can lead to more efficient processes, but it requires further study.

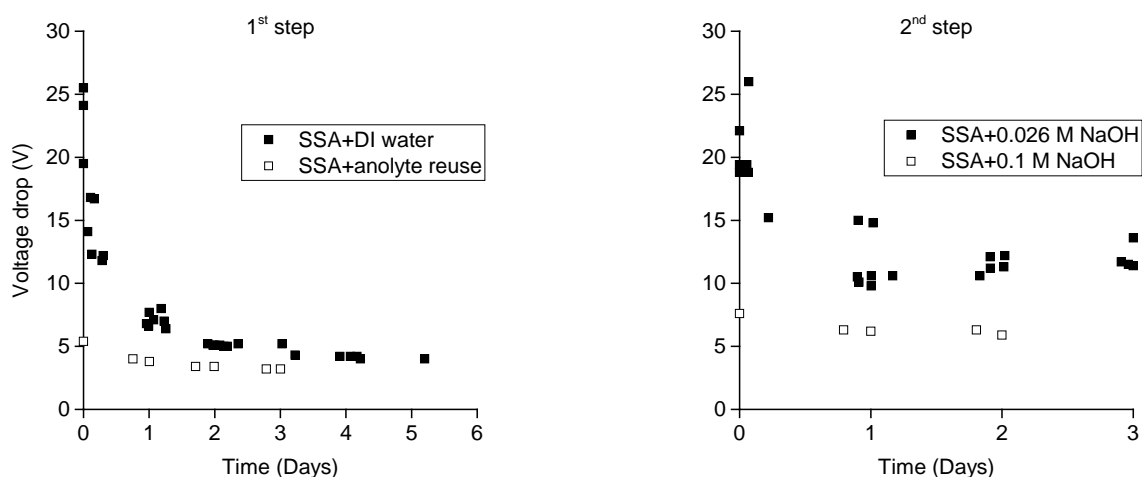

Fig. 15. Voltage evolution in sequential ED experiments of Randers SSA.

Another change which can help in lowering energy consumption is the use of an electrode with a high surface area, like a mesh electrode (Fig. 16), and the reduction of the distance between electrodes. In all ED experiments of this thesis, wire electrodes were always the choice, and normally separated by a distance of 12.5 cm. In order to understand the impact of each electrode and the distance, a 2C ED cell was built with two 5 cm long compartments separated by a CEM. The compartments were filled with 4 g/L of NaCl. Three different tests were made with this ED cell: one with a pair of wire electrodes separated 7.5 cm, and two with a pair of mesh electrodes separated 7.5 and 2.5 cm, respectively. With a current of 50 mA, the voltage drop across the cell was measured after 5 minutes; the results were 4.4 V for the wire electrodes, 3.8 V for the mesh electrodes separated 7.5 cm and 2.8 V for the mesh electrodes separated 2.5 cm. Thus, a considerable reduction in electrical consumption can be achieved with a different electrode shape and position in the ED setup. However, it requires to be addressed in future studies, because electrolysis reactions occurring closer to the IEM can lead to higher migration of H^+/OH^- instead of other ions of interest.

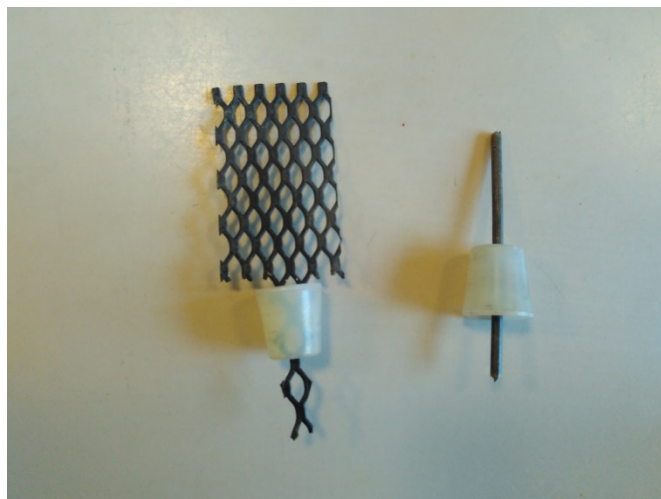

Fig. 16. Mesh (left) and wire (right) electrodes.

3.3.4 Other outputs from the electrochemical experiments

The ED process generated several outputs besides the P-recovery product (the analytes): the bulk SSA and the catholyte liquids in both steps of the sequential. All of them could have a second use:

- Some researchers have found potential in the usage of incineration SSAs in construction materials, although the recycling of bulk SSAs after a P recovery process has received little focus so far [68, 69]. Table 14 shows the concentrations of HM in bulk Stegholdt SSA after treatment with a 2C ED cell and Randers SSA at the end of the 2nd step of the sequential ED setup. Most HM were below Category 1 limits, the Danish guideline levels for the reuse of residues as construction materials [70]. The exceptions were Ni for Stegholdt SSA, as well as Zn and Pb for Randers SSA. Cd results were below the LOD, so no conclusion can be done for this element. Bjergmarken SSAs values are not shown, because Ni, Pb and Zn clearly exceed these limits. Thus, SSAs with high content in SiO₂ (paper I) might have a use in construction materials. Another potential use of the bulk SSAs after ED is in the production of insulation materials; nowadays, untreated incineration SSAs from Copenhagen area are commonly used for this purpose [28], with the consequent loss of P. Nevertheless, further research is required to assess the suitability of using each ED treated SSAs in the manufacturing of construction materials or insulation materials.

Table 14. Final concentration of the bulk SSAs after the ED experiments.

| Element | Bulk Stegholdt SSA | | | Bulk Randers SSA (1 st step duration) | | | Category 1 [70] | Units |
|---------|--------------------|---------------|---------------|--|---------------|------------------|-----------------|-------|
| | 1 day | 3 days | 7 days | 27.5 hours | 52.5 hours | 125 hours | | |
| As | <2* | <2* | <2* | <2-3.4 | <2* | <2*-3.1 | <20 | mg/kg |
| Cd | <2* | <2* | <2* | <2* | <2* | <2* | <0.5 | mg/kg |
| Cr | 23±0.4 | 22±0.1 | 19±0.4 | 31.5±2.9 | 25.0±1.3 | 42.7±9.5 | <500 | mg/kg |
| Cu | 39±0.6 | 28±0.2 | 23±0.4 | 132±7.7 | 97.7±4.2 | 140±23 | <500 | mg/kg |
| Ni | 65±1.0 | 53±0.4 | 41±0.7 | 25.3±1.2 | 23.7±6.8 | 29.1±4.5 | <30 | mg/kg |
| Pb | 7.6±1.0 | 5.4±0.4 | 3±0.9 | 38.7±2.2 | 32.8±0.9 | 52.5±9.8 | <40 | mg/kg |
| Zn | 98±1.8 | 65±0.5 | 65±1.3 | 869±33 | 664±16 | 1,114±330 | <500 | mg/kg |

*Below ICP-OES LOD.

- The catholyte liquid in the 1st step was mostly rich in Ca and nitrate. A processing of this solution could lead to calcium nitrate, a commonly produced fertilizer. However, a separation of the heavy metals, migrated from the anolyte, is required since the ratio of HM and Ca (not shown) was considerably higher than the values found in commercial calcium nitrate [26]. In like manner, such separation would allow HM recycling in the industry. A potential treatment can be the use of the use of polyelectrolyte-functionalized textiles, which are able to separate elements like Pd, Cu and, to a minor extent, Ni from Ca-rich acidic solutions [71]. The suitability of this technique to separate the different trace elements in the catholyte solutions produced in the ED treatment requires also a separate investigation.
- Copper was effectively separated from the catholyte solution in the 1st step by means of its deposition in the cathode following the reaction:

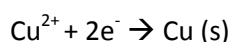

The mass of Cu recovered in the electrode of the 1st step (extracted with a 5 M HNO₃ solution) represented between 60 and 90% of the solubilised amount from Randers and both Bjergmarken SSAs. In most cases, the quantity of Cu recovered from the cathode was at least on order of magnitude higher than all other studied elements, which would ease its recycling to the industry.

- The catholyte liquid in the 2nd step was an alkaline solution containing mostly of Na, and could be reused in order to save the consumption of pure NaOH in the process.

Therefore, ED has the potential to valorise SSAs without generating waste, in contrast to the considerable generation of phosphogypsum produced in the current wet process of P-rock (chapter 1.3.1).

3.3.5 Low P concentration in the analytes

As seen in Table 10, the concentrations of P are several orders of magnitude lower than in WPA. In order to produce common fertilizers, the concentration should be increased. Using technologies based on heat transfer, common in the phosphoric acid industry which uses heat from sulfuric acid production [22], would imply a high amount of energy. An alternative can be the use of membrane technologies, as they have been proven more efficient in other sectors. For instance, the most common methods available in the water desalination industry are multi-stage flash distillation (MSF) and reverse osmosis (RO) [72]. The electrical consumption is similar for both MSF and RO: in the range of 2-4 kWh per m³ of recovered water, mostly required for pumping [73-75]. However, additional thermal energy (25-120 kWh/m³ of recovered water [76]) is required for MSF, making RO a lower energy-consuming technique.

An emerging membrane technology is Forward Osmosis (FO), which is expected to have lower fouling and less consumed energy than RO [77]. This technology utilizes the osmotic pressure of a draw solution (DS) to transport the solvent (normally water) from a feed solution (FS) through a semipermeable membrane, placed in a FO cell (Fig. 17). In order to keep the transport of solvent at a high flow, the DS is usually kept at constant concentration through other processes like RO; this could be avoided if the DS selected is a waste stream that needs some dilution. The energy consumption of the pumping system in FO for desalination, excluding the regeneration of the DS concentration, has been estimated to be around 0.3 kWh/m³ of recovered water [75], considerably lower than RO or MSF. Moreover, previous FO investigations with aqueous P-solutions showed a good P rejection [78]. With this process, it would be possible to increase the concentration of a diluted H₃PO₄ solution as FS and brine waste (i.e. from the fishing industry [79, 80]) as DS. In a research done in the external stay at The University of Hong Kong (HKU), a FO setup was used to concentrate two different acidic P-solutions, simulating the anolyte resulting from treating P with ED. Both solutions consisted of 1 liter of H₃PO₄ mixtures (10 g P/L) containing either 3 g Ca/L (by adding Ca(OH)₂) or 0.8 g Fe(III)/L (by adding Fe₂(SO₄)₃). This was done so as to investigate whether Ca or Fe(III) would interfere in the concentration process of H₃PO₄. The DS was 2 liters of NaCl 2 molal, a concentration which is in the range of herring brine waste [79]. The weight of the DS was monitored in a scale connected to a computer (Fig. 17), so as to control the flux and stop the experiments when it became too low (<0.5 kg·m⁻²·h⁻¹, Fig. 18a). Samples in the FS were taken at the beginning, after 24 hours and at the end of the FO, and the P concentration measured by ICP-OES.

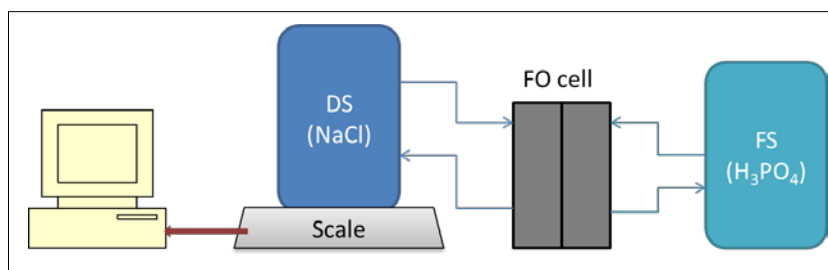

Fig. 17. FO diagram.

The results (Fig. 18b) show that P content was concentrated by a factor of around 4, with a retention of the initial P of 85% for the Ca-containing solution and 83% for the Fe(III)-containing solution. No precipitates or fouling (Fig. 18a) was observed during the experiments. Thus, FO has the potential to concentrate H_3PO_4 solutions, although it requires further research, as the system was not tested with real ED analyte solutions and the membranes brand used (HTI) were not intended for acidic solutions.

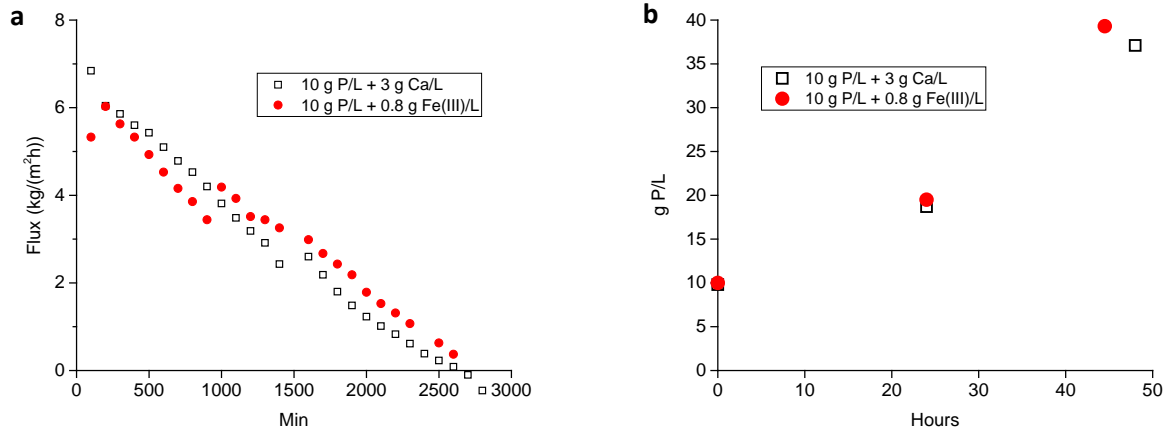

Fig. 18. Flux evolution (a) and concentration of P (b) during the FO experiments.

4. General conclusions

The characterization of four different SSAs showed that the compounds in which P can be found vary substantially depending on the P-immobilization technique at the WWTP (%chemical/biological P-precipitation) and the thermal treatment used (Pyroener/incineration). Generally, P is found in non to low plant-available compounds, such as Al, Ca or Fe(III)-phosphates. Another common feature is HM concentrations and HM/P: in the studied SSAs, they were normally within the limits of Danish legislation for sewage sludge or bioashes, but they were considerably higher than in commercial fertilizers. In consequence, a separation of P from the ashes was needed to ensure the bioavailability of P and to avoid HM accumulation in agricultural soils.

In order to achieve the separation of P, its bindings in each SSA (mostly controlled by Al, Ca and Fe) should be estimated. Among the investigated analysis (XRD, SEM and pH solubility), the best way to identify if there were a significant amount of Al/Fe(III)-P bindings was through an alkaline leaching. The results showed that a higher proportion of P was likely to be bound to Al/Fe(III) after the gasification using the Pyroener process than the incineration of chemically precipitated sewage sludge.

The separation of P from metal impurities (Al, Fe, Mg and HMs) in the four studied SSAs was achieved using different ED methods. The resulting product in all cases was always a H_3PO_4 solution with a level of metallic impurities comparable to WPA, the basic source of P for manufacturing most mineral fertilizers. The ED setup used depended on the bindings in which P was found. In biologically precipitated Pyroener SSAs and chemically precipitated incineration SSAs, with low influence of Al/Fe(III) on P solubility, a 2C ED cell allowed over 80% P-recovery in a process where ashes were acidified. In contrast, in chemically precipitated Pyroener SSAs, with a significant presence of alkaline-soluble Al/Fe(III)-phosphates, the use of two 2C ED cells connected sequentially was necessary to recover up to 70% of P. In this process, SSAs were acidified in the first ED cell followed by an alkalisation in a second ED cell. The usage of the step at high pH led also to a lower content in metallic impurities in the final product, as most metals were not soluble at alkaline pH. This sequential ED process could also be beneficial to recover a purer P-product from incineration SSAs, although it requires further study. When MER (Al, Fe and Mg ratio to P) was too high in the resulting H_3PO_4 solutions from either of these two methods, an alternative setup (split) was used. In the split setup, two anodes placed separately in two different compartments, which only one was in contact with the SSA suspension, were connected to the same cathode. This prevented an excessive load of protons generated at the anode, and thus reduced the dissolution of Al, Fe and/or Mg into the final product.

Further development of the ED method can lead to a higher rate of P-recovery from Pyroener SSAs and to lower energy consumption. The H_3PO_4 produced can also be up concentrated with low energy-consuming technologies like FO, although it needs to be addressed in future studies.

References

- [1] A. J. Pedersen *et al.*, "A Full-scale Study on the Partitioning of Trace Elements in Municipal Solid Waste Incineration-Effects of Firing Different Waste Types," *Energy and Fuels*, vol. 23, no. 7, pp. 3475-3489, 2009.
- [2] A. J. Pedersen, S. C. van Lith, F. Frandsen, S. D. Steinsen, and L. B. Holgersen, "Release to the gas phase of metals, S and Cl during combustion of dedicated waste fractions," *Fuel Processing Technology*, vol. 91, no. 9, pp. 1062-1072, 2010.
- [3] W. R. Niessen, *Combustion and incineration processes: applications in environmental engineering*. Taylor & Francis, 2010.
- [4] F. Frandsen, A. J. Pedersen, J. Hansen, O. H. Madsen, K. Lundtorp, and L. Mortensen, "Deposit Formation in the FASAN WtE Boiler as a Function of Feedstock Composition and Boiler Operation," *Energy and Fuels*, vol. 23, no. 7, pp. 3490-3496, 2009.
- [5] T. Astrup, C. Riber, and A. J. Pedersen, "Incinerator performance: effects of changes in waste input and furnace operation on air emissions and residues," *Waste Manag Res*, vol. 29, no. 10_suppl, 2011.
- [6] M. J. Quina, R. C. Santos, J. C. Bordado, and R. M. Quinta-Ferreira, "Characterization of air pollution control residues produced in a municipal solid waste incinerator in Portugal," *Journal of Hazardous Materials*, Article vol. 152, no. 2, pp. 853-869, Apr 2008.
- [7] D. M. o. E. Environmental Protection Agency, "Affaldsstatistik 2013 (In Danish)," 2015.
- [8] T. Astrup, "Pretreatment and utilization of waste incineration bottom ashes: Danish experiences," *Waste Management*, vol. 27, no. 10, pp. 1452-1457, 2007.
- [9] M. J. Quina, J. C. Bordado, and R. M. Quinta-Ferreira, "Treatment and use of air pollution control residues from MSW incineration: An overview," *Waste Management*, Review vol. 28, no. 11, pp. 2097-2121, Nov 2008.
- [10] O. Kruger and C. Adam, "Recovery potential of German sewage sludge ash," *Waste Management*, Article vol. 45, pp. 400-406, Nov 2015.
- [11] P. J. A. Withers *et al.*, "Stewardship to tackle global phosphorus inefficiency: The case of Europe," *Ambio*, Article vol. 44, pp. S193-S206, Mar 2015.
- [12] D. Panepinto, V. Tedesco, E. Brizio, and G. Genon, "Environmental Performances and Energy Efficiency for MSW Gasification Treatment," *Waste and Biomass Valorization*, vol. 6, no. 1, pp. 123-135, 2015.
- [13] N. Skoglund, A. Grimm, M. Ohman, and D. Bostrom, "Effects on Ash Chemistry when Co-firing Municipal Sewage Sludge and Wheat Straw in a Fluidized Bed: Influence on the Ash Chemistry by Fuel Mixing," *Energy & Fuels*, Article vol. 27, no. 10, pp. 5725-5732, Oct 2013.
- [14] J. Ahrenfeldt, T. Thomsen, U. B. Henriksen, and L. R. Clausen, "Biomass gasification cogeneration – A review of state of the art technology and near future perspectives," *Applied Thermal Engineering*, vol. 50, no. 2, pp. 1407-1417, 2013.
- [15] V. Hansen, D. Muller-Stover, J. Ahrenfeldt, J. K. Holm, U. B. Henriksen, and H. Hauggaard-Nielsen, "Gasification biochar as a valuable by-product for carbon sequestration and soil amendment," *Biomass & Bioenergy*, Article vol. 72, pp. 300-308, Jan 2015.
- [16] D. S. Müller-Stöver, J. Ahrenfeldt, J. K. Holm, S. G. S. Shalacet, U. B. Henriksen, and H. Hauggaard-Nielsen, "Soil application of ash produced by low-temperature fluidized bed gasification: effects on soil nutrient dynamics and crop response," *Nutrient Cycling in Agroecosystems*, vol. 94, no. 2-3, pp. 193-207, 2012.
- [17] K. Gorazda, Z. Wzorek, B. Tarko, A. K. Nowak, J. Kulczycka, and A. Henclik, "Phosphorus cycle - possibilities for its rebuilding," *Acta Biochimica Polonica, Acta Biochim. Pol, Act Bioch P, Acta Biochim Pol*, vol. 60, no. 4, pp. 725-730, 2013.

- [18] O. F. Schoumans, F. Bouraoui, C. Kabbe, O. Oenema, and K. C. van Dijk, "Phosphorus management in Europe in a changing world," *Ambio*, Article vol. 44, pp. S180-S192, Mar 2015.
- [19] DONG Energy Power A/S, "Pyroener website <<http://www.pyroener.com/en/gasification-process/process-description>> (last visited 11.08.2016)," ed.
- [20] *Sustainable phosphorus management : a global transdisciplinary roadmap*. 2014.
- [21] K. C. van Dijk, J. P. Lesschen, and O. Oenema, "Phosphorus flows and balances of the European Union Member States," *Science of the Total Environment, Sci. Total Environ, Sci Total E, Sci Total Environ, Sci Total Envir, Science of the Total Environment*, vol. 542, pp. 1078-1093, 2016.
- [22] *Phosphoric Acid Purification, Uses, Technology, and Economics*. CRC Pr I Llc, 2014.
- [23] W. P. Chen, A. C. Chang, and L. S. Wu, "Assessing long-term environmental risks of trace elements in phosphate fertilizers," *Ecotoxicology and Environmental Safety*, Article vol. 67, no. 1, pp. 48-58, May 2007.
- [24] H. Nacke, A. C. Goncalves, D. Schwantes, I. A. Nava, L. Strey, and G. F. Coelho, "Availability of Heavy Metals (Cd, Pb, and Cr) in Agriculture from Commercial Fertilizers," *Archives of Environmental Contamination and Toxicology*, Article vol. 64, no. 4, pp. 537-544, May 2013.
- [25] M. Molina, F. Aburto, R. Calderon, M. Cazanga, and M. Escudey, "Trace Element Composition of Selected Fertilizers Used in Chile: Phosphorus Fertilizers as a Source of Long-Term Soil Contamination," *Soil and Sediment Contamination*, vol. 18, no. 4, pp. 497-511, 2009.
- [26] M. B. McBride and G. Spiers, "Trace element content of selected fertilizers and dairy manures as determined by ICP-MS," *Communications in Soil Science and Plant Analysis*, Article vol. 32, no. 1-2, pp. 139-156, 2001.
- [27] "Denmark without waste," ed. The Danish Government, 2013.
- [28] BIOFOS A/S, "Miljøberetning (in Danish)," 2015.
- [29] BIOFOS A/S, "Udbudsmateriale for afhentning af slammaske til genbrug fra Renseanlæg Lynetten og Renseanlæg Avedøre (in Danish)," ed, 2014.
- [30] L. M. Ottosen, G. M. Kirkelund, and P. E. Jensen, "Extracting phosphorous from incinerated sewage sludge ash rich in iron or aluminum," *Chemosphere*, Article vol. 91, no. 7, pp. 963-969, May 2013.
- [31] S. Petzet, B. Peplinski, and P. Cornel, "On wet chemical phosphorus recovery from sewage sludge ash by acidic or alkaline leaching and an optimized combination of both," *Water Research*, Article vol. 46, no. 12, pp. 3769-3780, Aug 2012.
- [32] S. Donatello, D. Tong, and C. R. Cheeseman, "Production of technical grade phosphoric acid from incinerator sewage sludge ash (ISSA)," *Waste Management*, Article vol. 30, no. 8-9, pp. 1634-1642, Aug-Sep 2010.
- [33] J. Lehmkuhl and M. Lebek, "Purifying crude phosphoric acid, comprises reacting crude phosphoric acid with ash, calcium hydroxide and at least one sulfide, and depositing the acid-insoluble portion of the solids to obtain a filtrate or eluate," Patent DE102014006278-B3; WO2015165481-A1, Available: <Go to ISI>://DIIDW:2015143862.
- [34] M. Takhim, "Method for recovering ash from waste incineration used in e.g. agricultural field, involves digesting ash by leaching liquor containing phosphate ions and separating liquid phase comprising phosphate ions from solid phase," Patent WO2015091946-A1, Available: <Go to ISI>://DIIDW:201536069V.
- [35] Y.-Q. Liu, Y. Liu, J.-H. Tay, and Y.-T. Hung, "Biological Phosphorus Removal Processes," pp. 497-521, 2010.
- [36] G. Tchobanoglous and et al., *Wastewater engineering : treatment and resource recovery, Vol. 1*. McGraw-Hill, 2014.
- [37] M. Henze and et al., *Wastewater treatment : biological and chemical processes*. Springer, 2002.
- [38] C. S. Reynolds and P. S. Davies, "Sources and bioavailability of phosphorus fractions in freshwaters: a British perspective," *Biological Reviews*, Review vol. 76, no. 1, pp. 27-64, Feb 2001.

- [39] R. Li, Z. Zhang, Y. Li, W. Teng, W. Wang, and T. Yang, "Transformation of apatite phosphorus and non-apatite inorganic phosphorus during incineration of sewage sludge," *Chemosphere*, vol. 141, pp. 57-61, 2015.
- [40] A. B. Hernandez, J. H. Ferrasse, P. Chaurand, H. Saveyn, D. Borschneck, and N. Roche, "Mineralogy and leachability of gasified sewage sludge solid residues," *Journal of Hazardous Materials*, Article vol. 191, no. 1-3, pp. 219-227, Jul 2011.
- [41] S. Petzet, B. Peplinski, S. Y. Bodkhe, and P. Cornel, "Recovery of phosphorus and aluminium from sewage sludge ash by a new wet chemical elution process (SESAL-Phos-recovery process)," *Water Science and Technology*, Article vol. 64, no. 3, pp. 693-699, 2011.
- [42] K. Kuroda and M. Okido, "Hydroxyapatite Coating of Titanium Implants Using Hydroprocessing and Evaluation of Their Osteoconductivity," 2012.
- [43] P. Benzing and C. J. Rickardson, "CaCO₃ causes underestimation of NaOH extractable phosphorus in sequential fractionations," *Soil Science*, Article vol. 170, no. 10, pp. 802-809, Oct 2005.
- [44] P. Wilfert, P. S. Kumar, L. Korving, G.-J. Witkamp, and M. C. M. van Loosdrecht, "The Relevance of Phosphorus and Iron Chemistry to the Recovery of Phosphorus from Wastewater: A Review," *Environmental Science and Technology*, vol. 49, no. 16, pp. 9400-9414, 2015.
- [45] Y. Kalmykova and K. K. Fedje, "Phosphorus recovery from municipal solid waste incineration fly ash," *Waste Management, Waste Manage, Waste Man, Waste Manage, Waste Management, Waste Management Industrial Radioactive Hazardous, Waste Manag*, vol. 33, no. 6, pp. 1403-1410, 2013.
- [46] W. Stumm and J. J. Morgan, *Aquatic chemistry : Chemical equilibria and rates in natural waters*. Wiley, 1996.
- [47] R. W. Baker, "Membrane technology and applications," 2004.
- [48] G. M. Kirkelund, P. E. Jensen, A. Villumsen, and L. M. Ottosen, "Test of electro-dialytic upgrading of MSWI APC residue in pilot scale: focus on reduced metal and salt leaching," *Journal of Applied Electrochemistry*, Article; Proceedings Paper vol. 40, no. 6, pp. 1049-1060, Jun 2010.
- [49] G. M. Nystroem, L. M. Ottosen, and A. Villumsen, "Electrodialytic removal of Cu, Zn, Pb, and Cd from harbor sediment: Influence of changing experimental conditions," *Environmental Science & Technology*, Article vol. 39, no. 8, pp. 2906-2911, Apr 2005.
- [50] G. M. Nystroem, L. M. Ottosen, and A. Villumsen, "Acidification of harbor sediment and removal of heavy metals induced by water splitting in electro-dialytic remediation," *Separation Science and Technology*, Article vol. 40, no. 11, pp. 2245-2264, 2005.
- [51] P. E. Jensen, L. M. Ottosen, and C. Ferreira, "Electrodialytic remediation of soil fines (< 63 μ m) in suspension - Influence of current strength and L/S," *Electrochimica Acta*, Article; Proceedings Paper vol. 52, no. 10, pp. 3412-3419, Feb 2007.
- [52] B. Ebbers, L. M. Ottosen, and P. E. Jensen, "Comparison of two different electro-dialytic cells for separation of phosphorus and heavy metals from sewage sludge ash," *Chemosphere*, 2015.
- [53] B. Ebbers, L. M. Ottosen, and P. E. Jensen, "Electrodialytic treatment of municipal wastewater and sludge for the removal of heavy metals and recovery of phosphorus," *Electrochimica Acta*, vol. 181, pp. 90-99, 11/1/ 2015.
- [54] L. M. Ottosen, P. E. Jensen, H. K. Hansen, A. Ribeiro, and B. Allard, "Electrodialytic Remediation of Soil Slurry-Removal of Cu, Cr, and As," *Separation Science and Technology*, Article; Proceedings Paper vol. 44, no. 10, pp. 2245-2268, 2009.
- [55] L. M. Ottosen, A. T. Lima, A. J. Pedersen, and A. B. Ribeiro, "Electrodialytic extraction of Cu, Pb and Cl from municipal solid waste incineration fly ash suspended in water," *Journal of Chemical Technology and Biotechnology*, Article vol. 81, no. 4, pp. 553-559, Apr 2006.
- [56] L. M. Ottosen, P. E. Jensen, and G. M. Kirkelund, "Electrodialytic Separation of Phosphorus and Heavy Metals from Two Types of Sewage Sludge Ash," *Separation Science and Technology*, vol. 49, no. 12, pp. 1910-1920, 2014.

- [57] M. R. Jakobsen, J. Fritt-Rasmussen, S. Nielsen, and L. M. Ottosen, "Electrodialytic removal of cadmium from wastewater sludge," *Journal of Hazardous Materials*, vol. 106, no. 2-3, pp. 127-132, 2004.
- [58] A. J. Pedersen, "Characterization and electrodialytic treatment of wood combustion fly ash for removal of cadmium," *Biomass and Bioenergy*, vol. 25, no. 4, pp. 447-458, 2003.
- [59] G. M. Kirkelund, C. Magro, P. Guedes, P. E. Jensen, A. B. Ribeiro, and L. M. Ottosen, "Electrodialytic removal of heavy metals and chloride from municipal solid waste incineration fly ash and air pollution control residue in suspension - test of a new two compartment experimental cell," *Electrochimica Acta, Electrochim Acta, Electr Act, Electrochim. Acta*, vol. 181, pp. 73-81, 2015.
- [60] A. J. Pedersen, L. M. Ottosen, and A. Villumsen, "Electrodialytic removal of heavy metals from different fly ashes - Influence of heavy metal speciation in the ashes," *Journal of Hazardous Materials*, Article vol. 100, no. 1-3, pp. 65-78, Jun 2003.
- [61] G. M. Kirkelund, P. E. Jensen, and L. M. Ottosen, "Electrodialytic extraction of heavy metals from greenlandic MSWI Fly Ash as a function of remediation time and L/S ratio," *ISCORD 2013: Planning for Sustainable Cold Regions - Proceedings of the 10th International Symposium on Cold Regions Development*, pp. 87-96, 2013.
- [62] P. Guedes, N. Couto, L. M. Ottosen, G. M. Kirkelund, E. Mateus, and A. B. Ribeiro, "Valorisation of ferric sewage sludge ashes: Potential as a phosphorus source," *Waste Management, Waste Management, Waste Manage, Waste Man, Waste Management Industrial Radioactive Hazardous, Waste Manag*, 2016.
- [63] H. Strathmann, "Ion-exchange membrane separation processes," 2004.
- [64] A. W. Mann and R. L. Deutscher, "Solution geochemistry of lead and zinc in water containing carbonate, sulphate and chloride ions," *Chemical Geology, Chem Geol, Chem. Geol*, vol. 29, no. 29, pp. 293-311, 1980.
- [65] Danish Ministry of Environment, "Bekendtgørelse om anvendelse af affald til jordbrugsformål (Slambekendtgørelsen) BEK nr 1650 af 13/12/2006 (in Danish)," ed, 2006.
- [66] Danish Ministry of Environment, "Bekendtgørelse om anvendelse af bioaske til jordbrugsformål(Bioaskebekendtgørelsen) BEK nr 818 af 21/07/2008 (in Danish)," ed, 2008.
- [67] L. M. Ottosen, P. E. Jensen, and G. M. Kirkelund, "Phosphorous recovery from sewage sludge ash suspended in water in a two-compartment electrodialytic cell," *Waste Management*, vol. 51, pp. 142-148, 2016.
- [68] S. Donatello and C. R. Cheeseman, "Recycling and recovery routes for incinerated sewage sludge ash (ISSA): A review," *Waste Management*, Review vol. 33, no. 11, pp. 2328-2340, Nov 2013.
- [69] C. J. Lynn, R. K. Dhir, G. S. Ghataora, and R. P. West, "Sewage sludge ash characteristics and potential for use in concrete," *Construction and Building Materials, Constr Build Mater, Constr Buil, Construction and Building Materials, Constr. Build. Mater*, vol. 98, 2015.
- [70] Danish Ministry of Environment, "Bekendtgørelse om anvendelse af restprodukter og jord til bygge- og anlægsarbejder og om anvendelse af sorteret, uforurennet bygge- og anlægsaffald BEK nr 1414 af 30/11/2015 (in Danish)," ed, 2015.
- [71] K. Opwis, T. Mayer-Gall, and J. S. Gutmann, "Recovery of noble metals by the use of polyelectrolyte-functionalized textiles," in *Presentation at the 1st IWA Resource Recovery Conference* <<http://www.iwarr2015.org/sites/default/files/262/OPWIS%20-%20IWA%20-%20RR2015%20-%20Gent.pdf>> (last accessed 11.02.2016), Gent, Belgium, 2015.
- [72] L. F. Greenlee, D. F. Lawler, B. D. Freeman, B. Marrot, and P. Moulin, "Reverse osmosis desalination: Water sources, technology, and today's challenges," *Water Research*, vol. 43, no. 9, pp. 2317-2348, 2009.
- [73] M. A. Darwish, F. M. Al Awadhi, and M. Y. A. Raheem, "The MSF: Enough is Enough," *Desalination and Water Treatment*, vol. 22, no. 1-3, pp. 193-203, 2010.

-
- [74] N. M. Mazlan, D. Peshev, and A. G. Livingston, "Energy consumption for desalination : a comparison of forward osmosis with reverse osmosis, and the potential for perfect membranes," *Desalination*, vol. 377, pp. 138-151, 2016.
- [75] R. Semiat, J. Sapoznik, and D. Hasson, "Energy aspects in osmotic processes," *Desalination and Water Treatment*, vol. 15, no. 1-3, pp. 228-235, 2010.
- [76] R. Semiat, "Energy Issues in Desalination Processes," *Environmental Science and Technology*, vol. 42, no. 22, pp. 8193-8201, 2008.
- [77] M. A. Darwish, H. K. Abdulrahim, A. S. Hassan, A. A. Mabrouk, and A. O. Sharif, "The forward osmosis and desalination," *Desalination and Water Treatment*, vol. 57, no. 10, pp. 4269-4295, 2016.
- [78] J. F. Zhang, Q. H. She, V. W. C. Chang, C. Y. Y. Tang, and R. D. Webster, "Mining Nutrients (N, K, P) from Urban Source-Separated Urine by Forward Osmosis Dewatering," *Environmental Science & Technology*, Article vol. 48, no. 6, pp. 3386-3394, Mar 2014.
- [79] L. F. Sotoft, J. M. Lizarazu, B. R. Parjikolaei, H. Karring, and K. V. Christensen, "Membrane fractionation of herring marinade for separation and recovery of fats, proteins, amino acids, salt, acetic acid and water," *Journal of Food Engineering*, vol. 158, no. August, pp. 39-47, 2015.
- [80] N. Gringer, A. Osman, H. H. Nielsen, I. Undeland, and C. P. Baron, "Chemical Characterization, Antioxidant and Enzymatic Activity of Brines from Scandinavian Marinated Herring Products," *Journal of Food Processing and Technology*, vol. 5, no. 346, 2014.

Own publications

Paper I

"Electrodialytic extraction of phosphorus from ash of low-temperature gasification of sewage sludge", *Electrochimica Acta*, vol. 181, pp. 100-108, 2015.

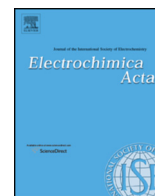

Electrodialytic extraction of phosphorus from ash of low-temperature gasification of sewage sludge



Raimon Parés Viader^{a,*}, Pernille Erland Jensen^a, Lisbeth M. Ottosen^a, Jesper Ahrenfeldt^b, Henrik Hauggaard-Nielsen^c

^a Department of Civil Engineering, Technical University of Denmark, Building 118, 2800 Kongens Lyngby, Denmark

^b Department of Chemical and Biochemical Engineering, Technical University of Denmark, Building 313, 4000 Roskilde, Denmark

^c Department of Environmental, Social and Spatial Change, Roskilde University, 4000 Roskilde, Denmark

ARTICLE INFO

Article history:

Received 8 January 2015

Received in revised form 25 April 2015

Accepted 6 May 2015

Available online 7 May 2015

Keywords:

Phosphorus

Low-temperature gasification

Sewage sludge ash

Electrodialysis

Heavy metals

ABSTRACT

Low-temperature gasification allows the production of energy from biomass with high contents of low melting point compounds, like sewage sludge, and the recycling of the nutrients as P from the resulting ashes as renewable fertiliser. Major drawbacks are, however, the presence of heavy metals and the low plant-availability of Al- and Fe- phosphate compounds in the gasification ashes. In the present research, the feasibility of a 2-compartment electro-dialytic (ED) setup for P separation from Al, Fe and heavy metals in two different low-temperature gasification ashes was investigated. One ash was from gasification of sewage sludge where P was precipitated with Fe and Al salts, from which it was possible to extract up to 26% of the P. The other ash was from co-gasification of a mixture of biologically precipitated sewage sludge and wheat straw pellets. More promising results were obtained with this ash, as up to 90% of the P was extracted from the ashes. For both ashes, P was extracted by ED in acidic aqueous solutions with ratios of Fe, Al and each heavy metal to P considerably below the values found in the initial ashes. Therefore, the 2-compartment ED cell technology was proved as possible method to separate Al, Fe and heavy metals from P for low-temperature gasification ashes.

© 2015 Elsevier Ltd. All rights reserved.

1. Introduction

Phosphorus is an essential element for life which has no biological or technological substitutes [1]. Current P supply for agriculture is dominated by phosphate rock (P-rock) fertilisers. However, the reserves of this mineral are estimated to be depleted in a period ranging from 50 to 400 years, depending on the study [2,3] and both the production and reserves are concentrated in Morocco, China and USA [4]. Thus, scarcity is likely to increase phosphate production costs by factor 3 to 5 in this century [5] and geopolitical issues might also influence both the cost and availability. In 2013, the European Union countries imported around 86% of the consumed P-rock, a dynamic observed at least over the last decade [6]. Today, only about one fourth of the P applied to agricultural fields is actually recycled [1]. Moreover, P-rock fertilisers have been a major contributor to the addition of heavy metals like Cd to soils over the last decades [7,8]. For all these

reasons, innovative recycling and re-use technologies need to be developed and implemented.

Paradoxically, while the global reserves of P-rock rapidly decline, urban and industrial regions generate increasing amounts of waste rich in organic phosphate that is currently not appropriately recycled and utilised [1]: P is usually immobilised and precipitated in sewage sludge during wastewater treatment by phosphate accumulating organisms [9] and/or by Fe/Al salts addition [10].

Low-temperature gasification allows an energy production from biomass resources like sewage sludge with high contents of low melting point ash compounds [11] – which are often shown to be a source of boiler operational problems in more traditional incineration [12]. The resulting sewage sludge ashes (SSA), with a high P content, could potentially be recycled back to agricultural soils after this thermal gasification process securing a safe renewable P fertiliser without the risk of applying organic contaminants like pharmaceuticals, detergent metabolites and others. Major drawbacks of using gasified SSA directly as fertiliser, however, are its heavy metal content and the presence of low plant available Al- and Fe- phosphates [13–15]. Hence, a mobilisation of

* Corresponding author. Tel.: +45 45252163.

E-mail address: rapv@byg.dtu.dk (R. Parés Viader).

P from the bulk gasification ashes and a simultaneous separation from heavy metals would be beneficial.

P separation from incinerated SSA can be achieved by acid leaching; but, heavy metals are also released [16–18]. Electrodialysis (ED) has been investigated as a technology to recover P from incineration SSA, from Al- and Fe- precipitation, and separate it from heavy metals, with a 3-cell compartment (Fig. 1a) [19,20]. In this set up, the ashes are placed in the middle compartment together with an acid solution and stirred constantly, so as to extract both P and heavy metals from incinerated SSA [19,20]. Released heavy metals are expected to be found as positively charged species and therefore migrating towards the catholyte during the ED treatment. In contrast, solubilised P is likely to be found in negatively charged or neutral species at acidic pH (H_3PO_4 , $\text{H}_2\text{PO}_4^{2-}$), except for Al-P and Fe-P complexes formation, so P ions would stay in the middle compartment and/or migrate towards the anolyte. In one of the studies, P separation into the middle compartment liquid and the anode compartment ranged around 15–85% for Al-precipitated incinerated SSA, a lower recovery than for Fe-precipitated ones which was around 45–95% [19]. In the other research, up to 70% of the P was recovered in the anode compartment [20].

Recently, a patent has been applied for a new set-up developed at the Technical University of Denmark, consisting of 2 compartments (Fig. 1a), which simplifies the experimental procedures in relation to the 3-compartment cell (Fig. 1b). The principle idea is that there is an acidification of the ash suspension by protons generated from electrolysis at the anode, and thus no acid addition is needed. The P remains in the filtrate of the ash suspension, instead of potentially dividing it between the anolyte and the middle compartment liquid. A study compared the performance of the two setups used in the P-recovery from incinerated SSA, and observed a lower voltage in the 2-compartment than in the 3-compartment ED cells by several orders of magnitude, when the ash was stirred only with water [21]. This can be due to a higher presence of ions in the suspension in the former than in the latter, as well as the use of one membrane and one electrolyte liquid instead of two. Thus, there is a potential saving on electricity and chemical costs with this new setup. Furthermore, with the 2-compartment setup it was possible to mobilise up to 90% of the P in the anode compartment [21]. No investigation has been made to recover P from gasification SSA by either acid or ED extraction, although the viability of low-temperature sewage sludge gasification depends partly on nutrient recycling. The aim of the present study was to test the technical feasibility of the 2-compartment ED cell to extract P, and separate it from Al, Fe and heavy metals, from SSA produced by low-temperature gasification of dried sewage sludge from two different plants.

2. Experimental

2.1. Gasification ashes

Two gasification ashes were collected from the second cyclone of a 100 kW experimental Low Temperature Circulating Fluid Bed gasifier (Fig. 2) at the Department of Chemical and Biochemical Engineering, Roskilde campus of the Technical University of Denmark [11]. The process is based on separate pyrolysis and gasification fluid bed reactors with a suitable circulating heating medium to transfer the heat from the gasification process to the pyrolysis. The temperature is kept below the melting point of the ash components (700–750 °C) avoiding sintering of the ash and subsequent fouling (from e.g. potassium) or corrosion (from e.g. chlorine) of the plant unit operations. The char conversion in the experimental Low Temperature Circulating Fluid Bed gasifier is a combination of sub-stoichiometric oxidation of the char and steam gasification [22]. The ash particles are circulated in the process until they are too small/light to be separated by the primary cyclone. Most of the ashes are separated out of the hot gas by the secondary cyclone [11], where they were sampled for this research. The original feedstocks of the two gasification ashes were:

- Randers ash: Dried sludge collected at the wastewater treatment plant in the municipality of Randers, Denmark, where P was captured 50% biologically and 50% chemically (with Fe and Al chlorides), approximately. The gasification took place in July 2013.
- Stegholdt ash: Wheat straw pellets (70% in weight) and dewatered sewage sludge (30% in weight) from Stegholdt wastewater treatment plant, Denmark, where P was mainly removed biologically with a minor amount of Fe salts. The co-gasification of both materials took place in June 2013.

2.2. Analytical methods and sampling

For both gasification ashes, small batches of around 200 grams were sampled from the total mass collected. Each ash was thereafter dried at 105 °C overnight, cooled in the fume hood, homogenised with a steel spatula and immediately stored in plastic bags and under dry conditions.

The concentration of elements was investigated for all untreated and treated gasification ashes. The targeted elements were: Al, Ca, Cd, Cu, Cr, Fe, K, Ni, P, Pb and Zn. The element content was measured by Varian 720-ES inductively coupled plasma optical emission spectrometry (ICP-OES) in six samples for the untreated ashes and in triplicates for the ED treated ashes after pre-treatment by Danish Standard DS259 [23]: 1 g ash and 20 mL 7.3 M HNO_3 were heated at 200 kPa (120 °C) for 30 min. The liquid

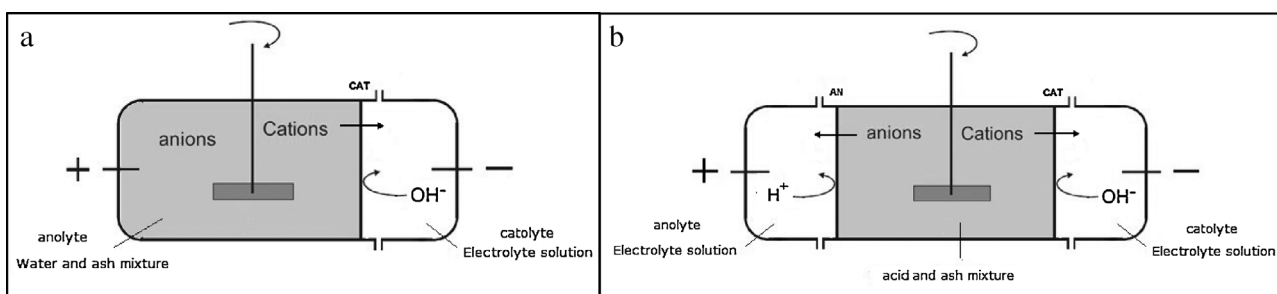

Fig. 1. Schematic view of a 2-compartment (a) and a 3-compartment (b) ED cell. CAT: cationexchange membrane. AN: anion-exchange membrane.

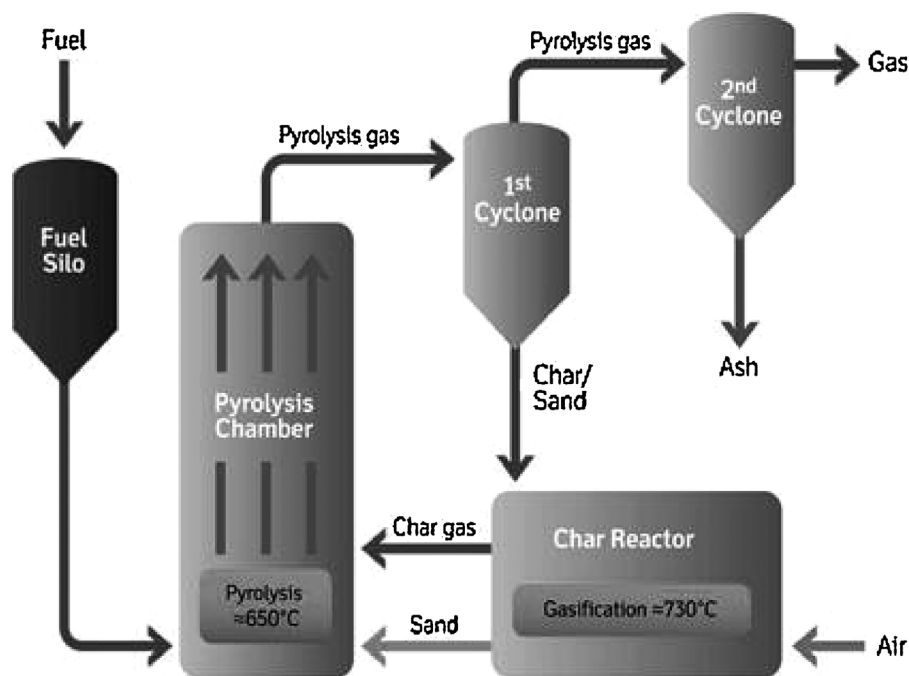

Fig. 2. Schematic of experimental Low Temperature Circulating Fluid Bed gasifier [11].

was thereafter separated by vacuum filtration through a 0.45 μm filter and diluted to 100 mL with deionised (DI) water.

Additionally, for the untreated gasification ashes, C and Si contents were measured. C concentration was determined using LECO induction furnace CS-200 Analyzer in triplicates, whereas Si content was measured by Varian MPX axial viewed ICP-OES in triplicates after digestion based on the Danish Standard EN 13656 [24]: 6 mL 35–37% HCl, 2 mL 65–70% HNO₃ and 2 mL 40–45% HF were added separately to 0.25 g of each ash, and heated in the microwave until the sample was completely dissolved. Hereafter 12 mL of 10% H₃BO₃ was added and the mixture was heated in the microwave for 20 min. The mineralogy of both untreated ashes was examined using X-ray powder diffraction (XRPD) with a

PANalytical X'Pert PRO, and the results were analysed using X'Pert HighScore Plus with ICDD PDF 2 database.

2.3. Acid extraction

In order to assess the dependence of solubility of the target elements to acidic solutions, 5 g of ash was shaken at 150 rpm for 1 week with 25 mL of HNO₃ at 1 M, 0.5 M, 0.3 M, 0.1 M and 0.01 M respectively. Additionally, the same procedure was repeated for Randers ash with HNO₃ 0.8 M. The pH of the leachate was measured by a Radiometer Analytical pH electrode. Element content in the leachate was measured by the Varian 720-ES ICP-OES after filtration through a 0.45 μm syringe filter.

Table 1

The concentration (average \pm standard deviation) of elements in the two studied gasification ashes. HM/P was calculated using average values. Values exceeding on average the Danish legislation for agricultural use are shown in bold. The results are compared with the element concentrations found in incineration SSA, gasification SSA and commercial fertilisers (CF).

| Element | per kg dry weight of sample | | | | Danish limits for agricultural use [29] | per kg P in sample (average values) | | | per kg P in Unit CF [7] | Unit |
|---------|-----------------------------|------------------------------|---------------------------------|-------------------|---|-------------------------------------|---------------|---|-------------------------|-------|
| | Randers ash | Stegholdt ash | Fe-rich SSA (literature values) | | | Randers ash | Stegholdt ash | Danish limits for agricultural use [29] | | |
| | | | Incineration [16–18,25] | Gasification [13] | | | | | | |
| Al | 9.5 \pm 1.3 | 3.1 \pm 0.1 | 20–166 | 23 | - | - | - | - | g/kg | |
| Ca | 36.7 \pm 5.1 | 35.3 \pm 3.7 | 54–163 | 110 | - | - | - | - | g/kg | |
| Fe | 57.6 \pm 8.3 | 6.2 \pm 0.7 | 47–170 | 88 | - | - | - | - | g/kg | |
| P | 32.4 \pm 4.6 | 18.6 \pm 1.8 | 39–109 | 102 | - | - | - | - | g/kg | |
| K | 1.7 \pm 0.3 | 83.3 \pm 4.3 | 4–23 | 8 | - | - | - | - | g/kg | |
| Si | 266 \pm 10.6 | 162 \pm 5.4 | 85–203 | 44 | - | - | - | - | g/kg | |
| C | 38.8 \pm 1.3 | 301 \pm 2.1 | - | 223 | - | - | - | - | g/kg | |
| Cd | <2.0*–3.14 | <2.0* | <0.4**–5 | ** | 0.8 | <61.7*–96.9 | <107.5* | 100 | 12–60 | mg/kg |
| Cr | 34 \pm 3.8 | 19 \pm 1.6 | 88–130 | 98 | 100 | 1,050 | 1,010 | - | 125–794 | mg/kg |
| Cu | 160 \pm 21 | 32 \pm 1.8 | 417–1,270 | 1,159 | 1,000 | 4,880 | 1,710 | - | 10–80 | mg/kg |
| Ni | 28 \pm 1.6 | 60\pm4.4 | 40–98 | 122 | 30 | 866 | 3,230 | 2,500 | 42–168 | mg/kg |
| Pb | 37 \pm 6.7 | 4.6 \pm 0.7 | 90–264 | 88 | 120 | 1,150 | 245 | 10,000 | 9–53 | mg/kg |
| Zn | 1,000 \pm 130 | 140 \pm 8.1 | 910–2,740 | 753 | 4,000 | 31,000 | 7,700 | - | 291–1,080 | mg/kg |

*Below ICP standards/**Below limit of detection.

2.4. ED experimental setup

The ED cell used is shown in Fig. 1b. It consisted of two compartments made of cylindrical Plexiglas® with an internal diameter of 8 cm. The anode compartment was 10 cm long and contained 35 g ash and 350 ml deionised water. A plastic strip attached to a glass-stick connected to an overhead stirrer (IKA RW11) was used to stir the ash suspension during the experiments. In the cathode compartment 500 mL electrolyte solution (0.01 M NaNO₃, pH < 2 adjusted with HNO₃) was circulated by a Totton Pump NDP 10/2. The electrodes were made of platinum coated titanium wire (diameter 3 mm) obtained from Permascand®. An Agilent E3612A DC power supply was used to maintain a constant DC current. The cation exchange membranes used were from Ionics (model CR67).

2.5. ED experiments

The durations of the ED experiments were 1, 3 and 7 days at 50 mA for both gasification ashes. The intensity was chosen following the findings from previous researches using ED for P extraction from incinerated SSA [19–21]. Voltage between the two electrodes was monitored during the whole experiment. The pH in both compartments and the conductivity of the ash suspension were measured daily during the ED experiments. The pH of the catholyte was adjusted to < 2 with HNO₃ 5 M, to avoid precipitations due to the production of OH⁻ by the electrode reaction at the inert cathode.

At the end of the experiments, the ash suspension was filtered at atmospheric pressure. The resulting liquid volume was measured and the ash was dried during 48 hours at 50 °C. The amount of liquid evaporated was measured by weight difference before and after drying. The dried ash was loosened by hand in a mortar and stored in plastic bags and under dry conditions. The volume of the catholyte was measured; the electrodes were rinsed in 5 M HNO₃, the membrane and the stirrer in 1 M HNO₃, and the concentrations of metals were measured in all of the liquids by ICP-OES after filtration through a 0.45 μm syringe filter.

Catholyte samples were taken in 20 mL vials before applying the electrical current and after 5 minutes of electrolyte circulation; at the end of the experiments, catholyte and anolyte samples were also taken in 20 mL vials. The element content was measured in the ICP-OES after filtration through a 0.45 μm syringe filter. The element content in the ashes before and after the experiments was measured as described in section 2.2.

3. Results and discussion

3.1. Characteristics of the untreated gasification ashes

The element content and the ratio of heavy metals and P (HM/P) of the gasification ashes are shown in Table 1. Most elements presented a considerable variability, which is due to the inherent inhomogeneity of the gasification ashes and it should be considered in further discussions. Cadmium concentration in the liquid from the ash sample digestion (as explained in section 2.2) was, in most cases, below the lowest standards used in the ICP measurements (0.02 mg/L). For this element, a range was given instead of the average together with the standard deviation of the six replicates. Furthermore, Cd results are not further discussed in the present work, as it is not possible to determine an accurate value and thereby whether Cd is effectively separated from P. As expected, Randers ash had a higher concentration of Fe and Al than Stegholdt ash; this is due to the usage of Fe and Al salts to precipitate P in Randers wastewater treatment plant, in contrast to its minor use in Stegholdt plant.

The P concentration in the ashes was around 3.2% and 1.9% respectively, which was below the range 3.9%–10.9% found in Fe-rich incinerated SSA [16–18,25] and gasified SSA resulting from steam gasification at 700 °C [13]. For Randers ash, this is due to a considerably higher concentration in Si. The source of this high Si content is probably the sand used during the Pyrener process. Indeed, the only mineral phase identified in the XRPD for this bio ash was quartz (SiO₂). Thus, Randers ash in fact consists of SSA diluted with sand.

For Stegholdt ash, the Si content was not as high as for Randers ash. Nonetheless, the Si content in the ashes was in the higher range of the previously reported in literature for incineration SSA [16–18,25] and similar to the concentration found in other wheat straw ashes from low-temperature gasification (180 mg per kg of dry sample [26]). For these ashes, there is most likely a parallel dilution of the P from Stegholdt sewage sludge with wheat straw (which normally has a lower P-content [26] than sewage sludge on a dry matter basis) and sand, which explains the lower content of P, compared to incineration SSA, gasification SSA and Randers ash (Table 1). Because of the feedstock proportion, these ashes had K content substantially higher than incinerated and gasified SSA (Table 1), but slightly lower than gasified wheat straw ashes (120 mg per kg of dry sample [26]). Accordingly, the mineral phases identified in the XRPD for Stegholdt ashes were SiO₂ and sylvite (KCl).

Unburned C content in both untreated ashes seemed not to be a major cause of P dilution: for Randers ash, C was around 4%, close

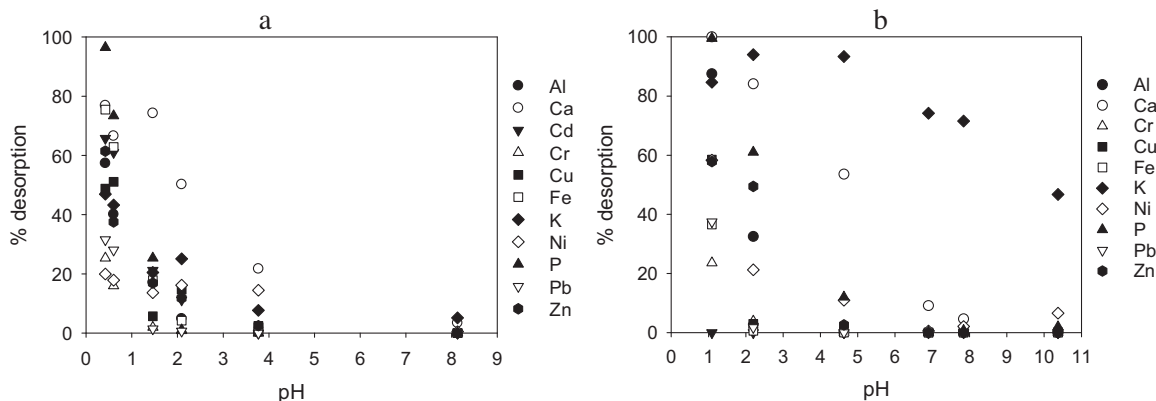

Fig. 3. Acid extraction of Al, Ca, Fe, K, P and heavy metals in a) Randers ash, b) Stegholdt ash.

to the maximum loss of ignition (3%) typically found in incinerated SSA [27] and well below the 22% found in other gasified SSA [13]. For Stegholdt ash, C content was around 30%, which is slightly higher than the concentration previously reported in gasified SSA (22.3%, Table 1).

Both ashes presented a black colour. Yet the reason can be different for each SSA: in Randers ash it is probably due to the presence of magnetite (Fe_3O_4) [28], which was previously identified in gasification SSA [14], whereas in Stegholdt ash it is most likely due to the higher content of unburned C.

The heavy metal concentrations were compared to Danish sewage sludge regulation limits for application in agriculture [29]. Only Ni limits were exceeded on average for Stegholdt ash. HM/P values found in commercial fertilisers [7] are included in Table 1, as a reference of the heavy metal content in the most common P-sources applied to agricultural soils. HM/P values were clearly higher in both Pyroneer ashes compared to commercial fertilisers for Cu, Ni, Pb and Zn. Cr/P was generally higher in the Pyroneer ashes, although the higher range found in commercial fertilisers had the same order of magnitude as both gasification ashes. In contrast, Cd/P ratio was in the range of commercial fertilisers for Randers ash and in the lower or below the range for Stegholdt ash. If applied in agricultural land on a basis of P dose without treatment, Pyroneer ashes would potentially increase heavy metal content in agricultural soils.

3.2. Acid extraction

As it can be seen in the acid extraction diagrams (Fig. 3), the lower the pH the higher the release of P and heavy metals. This makes an acidic extraction ineffective to produce a P-fertiliser with low content in heavy metals, which has similarly been observed from acid leaching on incinerated SSA [16–18]. Consequently, an additional step would be needed to separate P from heavy metals, if acid leaching was used.

Randers ash release of P (1%) at pH 2.1 (Fig. 3a) correspond to concentrations of $2.6 \cdot 10^{-3}$ M, which is above or close to the solubilities of FePO_4 (10^{-4} – 10^{-3} M) and AlPO_4 (10^{-3} – 10^{-2} M) at pH 2 [30], and below the ones of calcium phosphates like $\beta\text{-Ca}_3(\text{PO}_4)_2$ (between 10^{-2} [31] and 1 M [32]) and for Fe(II)-phosphates like vivianite ($\text{Fe}_3(\text{PO}_4)_2 \cdot 8\text{H}_2\text{O}$) (0.1 M [33]) at pH 3. Molar ratios, calculated from average concentrations (Table 1), are 0.34 for Al/P, 0.88 for Ca/P and 0.99 for Fe/P. Previous works indicated the presence of Al-, Ca- and Fe- phosphates in gasification SSA [13,14]. Consequently, P-solubility for Randers ash at acid pH are probably controlled by Fe(III), with some influence of Al- and Ca- bindings, although it requires further study for appropriate confirmation. The P solubility results (Fig. 3a) are considerably below the values observed for pH-desorption experiments for Fe-rich incinerated SSA, where 40–67% of the P solubilise at pH around 2 with the same liquid-to-solid ratio (L/S) [18]: Fe(III)-P compounds are not commonly present in Fe-rich incinerated SSA, as the trivalent iron phosphate bonds originally existing in sewage sludge are broken during incineration, resulting in the formation of more acid-soluble Ca-phosphates [19,34,35] as well as acid-insoluble Fe-

oxides [34–36]. The low solubility of P in Randers SSA implies a low plant-availability [15], which is a hindrance for its direct fertilizer application in agricultural soils.

In the Stegholdt ash around 60% of the P was released at pH 2.2 (Fig. 3b), corresponding to a concentration $7.9 \cdot 10^{-2}$ M, which is more than one order of magnitude higher than Randers SSA value at pH 2.1. This is probably due to the lower influence of Fe(III) and Al in P-solubility in these ashes. Indeed, molar ratios of Al/P and Fe/P, calculated from average concentrations (Table 1), are 0.18, well below stoichiometric ratios of Al- and Fe- phosphates, in contrast with Ca/P ratio (1.5). These facts, together with the high leaching of Ca (80%), indicate the high presence of Ca-P bindings.

3.3. ED experiments

3.3.1. Element distribution at the end of the ED experiments

The distribution of the elements in the cell at the end of the remediation for each ED experiment was determined, considering that:

- Since the resulting ash retained some P-rich liquid from the anolyte during the filtration, a subtraction of the mass of each element found in the anolyte was made to the direct measurement of element content in the treated ashes. The resulting amount was considered as the element found in the bulk ash. The element mass subtracted was found by means of multiplying the concentrations found in the ICP-OES for the P-rich solution and the volume of liquid dried (section 2.5), assuming a liquid density equal to water.
- The mass of each element subtracted from the treated ashes, explained in the previous point, was added to each element mass found in the filtrate of the ash suspension since it is potentially mobile through water washing, and the sum was considered to be separated in the anolyte.
- The catholyte, the cathode and the cationic membrane were grouped as the cathode compartment.
- The total mobilisation of each element, including P, was the sum of the masses found in anolyte solution, the anode, the stir and in cathode compartment.

The element contents found precipitated at the stirrer and the anode were always below 0.1% of the initial content in the untreated ash. Therefore, their results are not shown in detail in the present study.

3.3.2. Mass balances and ash inhomogeneity

Mass balances for each element, defined as the relation between the sum of mass found in the different ED cell compartments at the end of the experiments and the amount initially found in the mass of untreated ash placed in the ED cell, were made to control the quality of the experiments (Table 2). Results between 90 and 110% were considered acceptable. Elements were in this range for Randers ash in five out of six cases, whereas it was only six out of ten for Stegholdt ash. The most noticeable results are Cr and Pb for Stegholdt ashes, which can be

Table 2
Mass balances (%) for the ED experiments. Values outside 90–110% range are shown in bold.

| Remediation time | Gasification ash | Al | Ca | Fe | P | K | Cr | Cu | Ni | Pb | Zn |
|------------------|------------------|------------|-----|------------|-----------|------------|------------|------------|-----|------------|-----|
| 1 day | Randers | 101 | 101 | 99 | 98 | 101 | 106 | 96 | 104 | 101 | 107 |
| | Stegholdt | 110 | 93 | 100 | 70 | 94 | 176 | 123 | 100 | 223 | 104 |
| 3 days | Randers | 88 | 101 | 86 | 90 | 97 | 89 | 77 | 93 | 86 | 92 |
| | Stegholdt | 99 | 90 | 102 | 77 | 84 | 157 | 107 | 94 | 195 | 90 |
| 7 days | Randers | 104 | 105 | 101 | 103 | 112 | 106 | 110 | 107 | 108 | 105 |
| | Stegholdt | 122 | 100 | 119 | 77 | 107 | 103 | 77 | 98 | 108 | 98 |

due to the inherent inhomogeneity of elements found in trace levels, and indicate that a better homogenization before sampling from small batches (see section 2.2) might be needed. Concentration measurements which were below the lowest standard used in the ICP analyses (0.02 mg/L), only affecting Cr and Pb concentrations in the anolyte for some cases, were considered as 0.02 mg/L for the mass balances and for further calculations in the present work like the ratio HM/P. The overall impact of this approximation was small as the element mass were below 2% of the total final amount found at the end of the ED experiments.

3.3.3. P-separation results

ED applied to Randers ash gave a separation of P in the anolyte ranging 13–26%, depending on the remediation time (Fig. 4a): the longer the experiment, the higher the extraction of P. The pH of the anolyte was reduced in parallel to the increase in remediation time, due to the production of H⁺ at the anode through electrolysis of water:



As seen in section 3.2, acidification of the ash suspension favoured P and other elements release. However, the P-extraction after ED was visibly higher than the acid extraction results at similar pH. The total mobilisation of P (Fig. 4a) was 13% after 1 day (pH 2.2), 28% after 3 days (pH 1.7) and 34% after 7 days (pH 1.6). In the acid extraction experiments, 1% P was released at pH around 2.1, and 25% at pH 1.5 (Fig. 3a). The reason for a higher release of P in ED experiments can be a combination of an increased solubilisation of P compounds, due to equilibrium displacement by Al, Ca and Fe cations migration into the catholyte, together with a higher liquid-to-solid ratio (L/S) in the ED remediation (L/S=10) than in the acid extraction experiments (L/S=5). Moreover, the longer reaction time in the acid extractions could imply a lower P-extraction, as observed in a previous work when comparing acid P-extraction from incineration SSA for 2 hours and 1 week at different L/S, probably due to re-precipitation or adsorption of P over the time [18]. Further research is required to compare the ED with the acid extraction of P, from SSA similar to Randers ash, at the same pH and L/S, as well as the influence of the reaction time.

It should be noted that the difference of P separation to the anolyte between 3 (23%) and 7 (26%) days was not remarkable, and that these rates were considerably lower than previously reported from 2-compartment ED experiments with Fe-rich incinerated SSA for 7 days (around 80% [21]) also at 50 mA. The poor separation of P from Randers ashes in comparison to incineration SSA is rather due

to the ash characteristics than the ED setup. The reason is most likely to be the Fe(III) role in P-solubility at acid pH in Randers ashes, as discussed in the section 3.2. At the end of experiments, less than 5% Al and Fe was found in the anolyte; the rest of these two elements mostly remained in the bulk ashes (above 80%) and, to a minor extent, migrated to the cathode compartment. The resulting mass ratio in the anolyte ranged 50–100 for P/Al and 10–150 for P/Fe, depending on the remediation time, whereas in the untreated ash they were 3.4 for P/Al and 0.6 for P/Fe using average values (Table 1). Thus P was effectively separated from Al and Fe for Randers ash with the present ED setup.

An increase in ED duration could imply a higher P extraction due to a pH decrease; however, higher amounts of Fe and Al were also released in more acidic conditions as seen in Fig. 3a. This fact could lead to the formation of positively charged Fe-P and/or Al-P complexes. Calculations with MINTEQA2, using the concentrations found in the anolyte for P, Al, Fe (Fe (II) or Fe (III)) and Ca at the end of the 7-day ED experiment and a pH of 1.6, showed a major formation of positively charged Fe-P complexes like $\text{Fe}(\text{H}_2\text{PO}_4)^{2+}$ and $\text{Fe}(\text{HPO}_4)^+$ or $\text{Fe}(\text{H}_2\text{PO}_4)^+$ (Table 3). If higher proportions of Fe are released, such complexes are likely to form in higher percentages. As these complexes are positively charged, P would migrate towards the cathode during ED, which jeopardises the separation to the anolyte. Indeed, the difference between the P found in the anolyte and the total mobilisation increased with increased ED duration and following decrease in pH: 0.5%, 5% and 8% after 1, 3 and 7 days of ED, respectively. This is likely due to a higher proportion of the abovementioned positively charged Fe-P complexes at longer duration, and consequent migration to the cathode compartment. Therefore even at prolonged treatment times, P and heavy metals cannot be sufficiently separated by the investigated technique when high amounts of Fe are simultaneously dissolved.

ED was also applied to the Stegholdt ash, showing more encouraging results than Randers ash. The P found in the anolyte was around 54%, 87% and 90% after 1, 3 and 7 days respectively (Fig. 4b). These results should be taken with care, as mass balances were within the range 70–77% (see Table 3). However, they clearly indicate a high rate of P-separation for Stegholdt ash. As in the case of the Randers ash, the % P in the anolyte was not much higher at 7 than at 3 days. The high P-extraction results are possibly due to the high content in Ca-P compounds, which are more acid-soluble than Al- and Fe- phosphates (see section 3.2). Similarly to Randers ash results, P/Al and P/Fe mass ratios in the anolyte at the end of the ED experiments were higher than in the initial ash: in the range of 15–

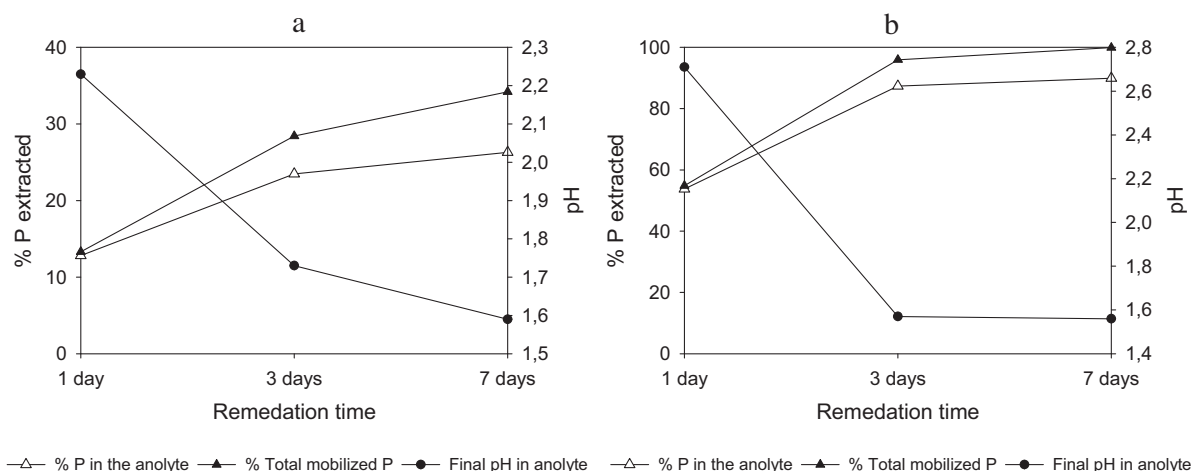

Fig. 4. P separated in the anolyte after ED treatment at different remediation times from a) Randers ash, b) Stegholdt ash.

Table 3
MINTEQ calculation of major speciation of Al, Ca, Fe(II)/Fe(III) and phosphate ions for the anolyte concentrations of Randers ash 7-day ED treatment at pH=1.6.

| Element | Total ion concentration (mg/L) | Major species distribution (Fe as Fe ²⁺) | Major species distribution (Fe as Fe ³⁺) |
|---------|--|---|---|
| Al | 24 (as Al ³⁺) | 86.7% Al ³⁺ , 13.2% Al(HPO ₄) ⁺ | 87.8% Al ³⁺ , 12.2% Al(HPO ₄) ⁺ |
| Ca | 187 (as Ca ²⁺) | 93.0% Ca ²⁺ , 7.0% Ca(H ₂ PO ₄) ⁺ | 96.1% Ca ²⁺ , 3.9% Ca(H ₂ PO ₄) ⁺ |
| Fe | 276 (as Fe ²⁺ or Fe ³⁺) | 37.3% Fe ²⁺ , 62.7% Fe(H ₂ PO ₄) ⁺ | 1.5% Fe ³⁺ , 60.1% Fe(H ₂ PO ₄) ²⁺ , 38.2% Fe(HPO ₄) ⁺ |
| P | 2864 (as PO ₄ ³⁻) | 22.4% H ₂ PO ₄ ⁻ , 65.9% H ₃ PO ₄ , 0.4% Al(HPO ₄) ⁺ , 1.1% Ca(H ₂ PO ₄) ⁺ , 10.3% Fe(H ₂ PO ₄) ⁺ | 21.0% H ₂ PO ₄ ⁻ , 61.5% H ₃ PO ₄ , 0.4% Al(HPO ₄) ⁺ , 1.0% Ca(H ₂ PO ₄) ⁺ , 9.9% Fe(H ₂ PO ₄) ²⁺ , 6.3% Fe(HPO ₄) ⁺ |

100 for P/Al and 50–250 for P/Fe, whereas in the untreated ash these ratios were 6 and 3 using average values (Table 1), respectively.

The final concentration of P in the anolyte varied from 0.5 to 0.9 g P/L for Randers ash leachates, and from 0.6 to 1.4 g P/L for the Stegholdt ash leachates. These values were well below the concentration found in commercial phosphoric acid (450 g P/L approximately) as well as in liquid fertilisers, examples of which vary approximately from 11 to 230 g P/L [37]. A higher P-concentration could possibly be reached by reducing the L/S in the experiments. The Stegholdt ash contained a high concentration of K from the straw. This is another important nutrient (however not scarce) and in the future the process could be extended also to recover K. In the present setup though, around 80% of the total K migrated to the catholyte together with the heavy metals so a separation step is needed (e.g. increasing pH so the heavy metals precipitate and K remains in solution).

3.3.4. Heavy metal reduction results

At the end of the ED treatment, at least 80% (and in most of the cases above 95%) of the mass of heavy metals was found either in the bulk ash or in the cathode compartment. Consequently, for both ashes, HM/P in the anolyte was considerably lower than in the original material in most cases, showing an efficient heavy metal load reduction (Figs. 5 and 6) in the P-solution of the anolyte. Such reduction was observed when treating incineration SSA with both the 2- and 3-compartment ED cell [19,20]. The HM/P in the anolyte for Cr and Pb were below or in the usual values found for commercial fertilisers for all treatment times (Figs. 5, 6 and Table 1). For the rest of heavy metals (Cu, Ni and Zn) there was a promising approach to fertiliser values (Figs. 5, 6 and Table 1), but more research is needed in order to achieve them.

3.3.5. ED cell voltage and ash suspension conductivity

The voltage between the two electrodes decreased continuously during the ED experiments for both SSA, in parallel to the

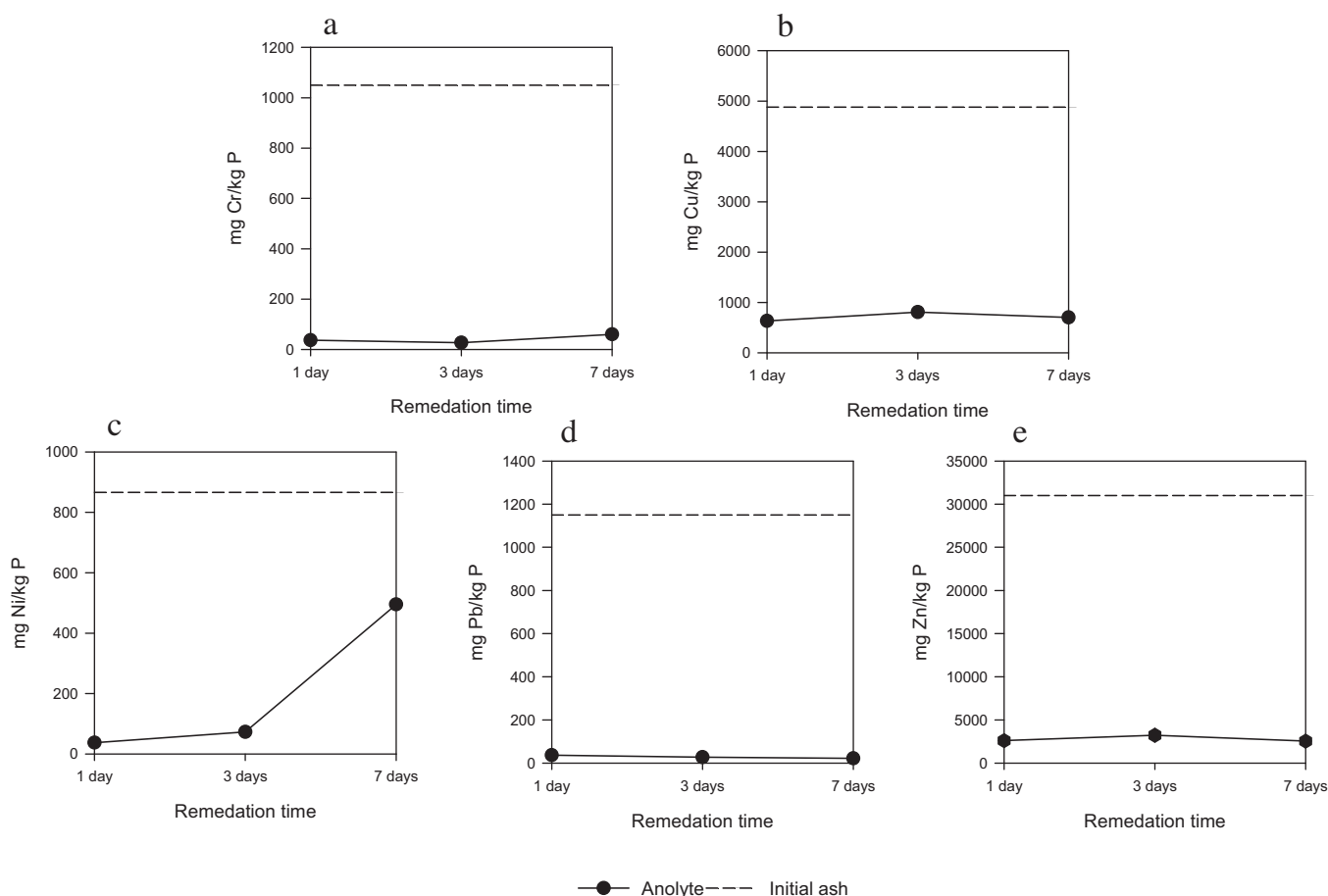

Fig. 5. a-e: Ratio of heavy metals and P in the initial ash and in the anolyte at the end of the ED treatment at different remediation times for Randers ash.

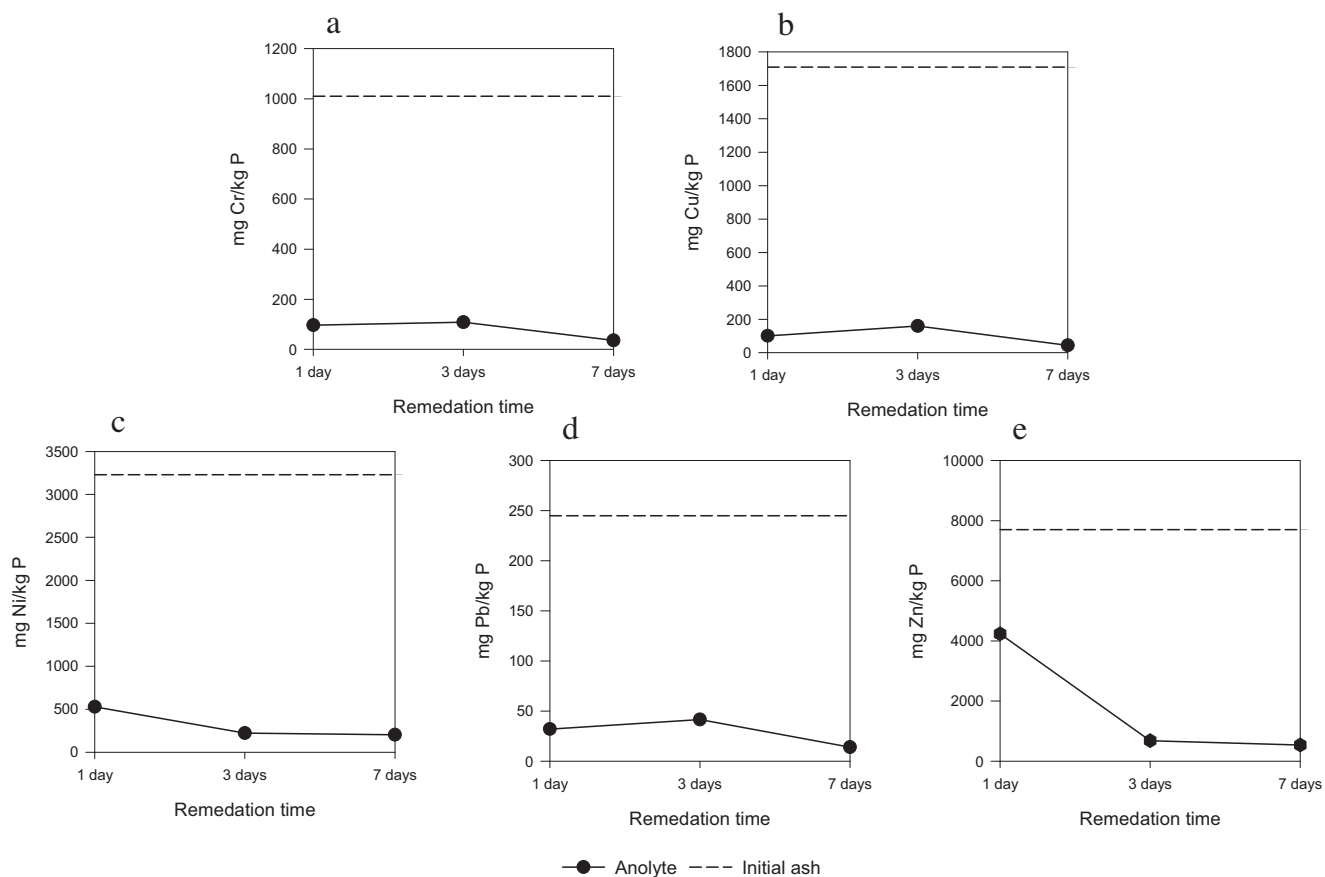

Fig. 6. a-e: Ratio of heavy metals and P in the initial ash and in the anolyte at the end of the ED treatment at different remediation times for Stegholdt ash.

increase in conductivity of the ash suspension. This was similarly observed in a previous work on electrolysytic remediation of incinerated SSA with the two-cell compartment [21]. The rise in conductivity in the suspension is due to the higher presence of protons, generated by electrolysis at the anode, and other ions released from the ashes as the suspension pH drops. Furthermore, the decrease in electrical resistivity in the ED cell during the experiments indicates the absence of significant fouling or deposit formation on the cationic exchange membrane, usually caused by calcium hydroxides and carbonates in ED processes [38].

4. Conclusion

The 2-compartment electrolysytic (ED) cell technology is an effective method to separate P from Al, Fe and heavy metals for gasified sewage sludge ashes (SSA). However, further work is required to achieve a higher ED extraction of P from chemically precipitated sewage sludge gasification ashes. It was possible to extract up to 26% of the P in the anolyte from chemically precipitated sewage sludge gasification ash, and up to 90% of the P from co-gasified wheat straw and biologically precipitated SSA. The presence of Fe-P bindings and the formation of positively charged Fe-P complexes in the ash from chemically precipitated sewage sludge were hampering the optimal ED separation. The ratios of Al, Fe, most heavy metals and P in the anolyte solutions were considerably below the one in the initial ashes; noticeably, for Cr and Pb they were below or in the range of commercial fertilisers. This is because most of the studied metals either remained in the ashes or migrate to the catholyte in case of solubilisation.

Acknowledgements

The Energy Technology Development and Demonstration Program, Danish Ministry of Climate, Energy and Buildings is acknowledged for funding this research as part of the project “Fuel Flexible, Efficient and Sustainable Low Temperature Biomass Gasification”.

References

- [1] D.L. Childers, J. Corman, M. Edwards, J.J. Elser, Sustainability Challenges of Phosphorus and Food: Solutions from Closing the Human Phosphorus Cycle, *Bioscience* 61 (Feb) (2011) 117–124.
- [2] D. Cordell, J.O. Drangert, S. White, The story of phosphorus: Global food security and food for thought, *Global Environmental Change-Human and Policy Dimensions* 19 (May) (2009) 292–305.
- [3] C.J. Dawson, J. Hilton, Fertiliser availability in a resource-limited world: Production and recycling of nitrogen and phosphorus, *Food Policy* 36 (Jan) (2011) S14–S22.
- [4] USGS, <http://minerals.usgs.gov/minerals/pubs/commodity/phosphate_rock/> (last accessed 02.10.2014).
- [5] D.P. Van Vuuren, A.F. Bouwman, A.H.W. Beusen, Phosphorus demand for the 1970–2100 period: A scenario analysis of resource depletion, *GLOBAL ENVIRONMENTAL CHANGE-HUMAN AND POLICY DIMENSIONS* 20 (2010) 428–439.
- [6] IFA, <http://www.fertilizer.org/en/doc_library/Statistics/PIT/Phosphate_Rock_public.xlsx> (last accessed 25.03.2015).
- [7] M.B. McBride, G. Spiers, Trace element content of selected fertilizers and dairy manures as determined by ICP-MS, *Communications in Soil Science and Plant Analysis* 32 (2001) 139–156.
- [8] S.S. Mar, M. Okazaki, Investigation of Cd contents in several phosphate rocks used for the production of fertilizer, *Microchemical Journal* 104 (Sep) (2012) 17–21.
- [9] Y.-Q. Liu, Y. Liu, J.-H. Tay, Y.-T. Hung, Biological Phosphorus Removal Processes (2010) 497–521.

- [10] M. Henze, et al., *Wastewater treatment: biological and chemical processes*, Springer, 2002, 2015.
- [11] J. Ahrenfeldt, T. Thomsen, U.B. Henriksen, L.R. Clausen, Biomass gasification cogeneration—A review of state of the art technology and near future perspectives, *Applied Thermal Engineering* 50 (2013) 1407–1417.
- [12] N. Skoglund, A. Grimm, M. Ohman, D. Bostrom, Effects on Ash Chemistry when Co-firing Municipal Sewage Sludge and Wheat Straw in a Fluidized Bed: Influence on the Ash Chemistry by Fuel Mixing, *Energy & Fuels* 27 (Oct) (2013) 5725–5732.
- [13] A.B. Hernandez, J.H. Ferrasse, P. Chaurand, H. Saveyn, D. Borschneck, N. Roche, Mineralogy and leachability of gasified sewage sludge solid residues, *Journal of Hazardous Materials* 191 (Jul) (2011) 219–227.
- [14] N. Gil-Lalaguna, J.L. Sanchez, M.B. Murillo, G. Gea, Use of sewage sludge combustion ash and gasification ash for high-temperature desulphurization of different gas streams, *FUEL* 141 (2015) 99–108.
- [15] C.S. Reynolds, P.S. Davies, Sources and bioavailability of phosphorus fractions in freshwaters: a British perspective, *Biological Reviews* 76 (Feb) (2001) 27–64.
- [16] S. Donatello, D. Tong, C.R. Cheeseman, Production of technical grade phosphoric acid from incinerator sewage sludge ash (ISSA), *Waste Management* 30 (Aug-Sep) (2010) 1634–1642.
- [17] M. Franz, Phosphate fertilizer from sewage sludge ash (SSA), *Waste Management* 28 (2008) 1809–1818.
- [18] L.M. Ottosen, G.M. Kirkelund, P.E. Jensen, Extracting phosphorus from incinerated sewage sludge ash rich in iron or aluminum, *Chemosphere* 91 (May) (2013) 963–969.
- [19] L.M. Ottosen, P.E. Jensen, G.M. Kirkelund, Electrodialytic Separation of Phosphorus and Heavy Metals from Two Types of Sewage Sludge Ash, *Separation Science and Technology* 49 (2014) 1910–1920.
- [20] P. Guedes, N. Couto, L.M. Ottosen, A.B. Ribeiro, Phosphorus recovery from sewage sludge ash through an electrodialytic process, *WASTE MANAGEMENT* 34 (2014) 886–892.
- [21] B. Ebbens, L.M. Ottosen, P.E. Jensen, Comparison of two different electrodialytic cells for separation of phosphorus and heavy metals from sewage sludge ash, *Chemosphere* (2015) .
- [22] V. Hansen, D. Müller-Stöver, J. Ahrenfeldt, J.K. Holm, U.B. Henriksen, H. Hauggaard-Nielsen, Gasification biochar as a valuable by-product for carbon sequestration and soil amendment, *Biomass and Bioenergy*. (2015) .
- [23] Danish standard, "Determination of metals in water, sludge and sediments - General guidelines for determination by atomic absorption spectrophotometry in flame," ed, 2003.
- [24] Danish Standard, "DS/EN 13656: Characterization of waste - Microwave assisted digestion with hydrofluoric (HF), nitric (HNO₃) and hydrochloric (HCl) acid mixture for subsequent determination of elements," ed, 2003.
- [25] C. Adam, B. Peplinski, M. Michaelis, G. Kley, F.G. Simon, Thermochemical treatment of sewage sludge ashes for phosphorus recovery, *Waste Management* 29 (Mar) (2009) 1122–1128.
- [26] D.S. Müller-Stöver, J. Ahrenfeldt, J.K. Holm, S.G.S. Shalatek, U.B. Henriksen, H. Hauggaard-Nielsen, Soil application of ash produced by low-temperature fluidized bed gasification: effects on soil nutrient dynamics and crop response, *Nutrient Cycling in Agroecosystems* 94 (2012) 193–207.
- [27] S. Donatello, C.R. Cheeseman, Recycling and recovery routes for incinerated sewage sludge ash (ISSA): A review, *Waste Management* 33 (Nov) (2013) 2328–2340.
- [28] Q.-L. Ye, H. Yoshikawa, S. Bandow, K. Awaga, Green magnetite (Fe₃O₄): Unusual optical Mie scattering and magnetic isotropy of submicron-size hollow spheres, *APPLIED PHYSICS LETTERS* 94 (2009) .
- [29] Danish Ministry of Environment, "Bekendtgørelse om anvendelse af affald til jordbrugsformål (Slambekendtgørelsen) BEK nr 1650 af 13/12/2006 (in Danish)," ed, 2006.
- [30] W. Stumm, J.J. Morgan, *Aquatic chemistry: Chemical equilibria and rates in natural waters*, Wiley, 1996, 2015.
- [31] H.B. Pan, B.W. Darvell, Solubility of TTCP and β-TCP by solid titration, *Archives of Oral Biology* 54 (2009) 671–677.
- [32] K. Kuroda and M. Okido, *Hydroxyapatite Coating of Titanium Implants Using Hydroprocessing and Evaluation of Their Osteoconductivity*, 2012.
- [33] H.E.L. Madsen, H.C.B. Hansen, Kinetics of crystal growth of vivianite, Fe-3(PO₄) (2) center dot 8H(2)O, from solution at 25, 35 and 45 degrees C, *Journal of Crystal Growth* 401 (Sep) (2014) 82–86.
- [34] M.A. Martinez, G. Gea, J. Arauzo, S.R.A. Kersten, A.M.J. Kootstra, Phosphorus recovery from sewage sludge char ash, *Biomass & Bioenergy* 65 (Jun) (2014) 42–50.
- [35] K. Gorazda, Z. Kowalski, Z. Wzorek, From sewage sludge ash to calcium phosphate fertilizers, *Polish Journal of Chemical Technology* 14 (2012) 54–58.
- [36] Y. Cohen, Phosphorus dissolution from ash of incinerated sewage sludge and animal carcasses using sulphuric acid, *Environmental Technology* 30 (2009) 1215–1226.
- [37] DanGødning, <<http://www.dangodning.dk/index.php?s=sortiment.php>> (last accessed 18.11.2014), .
- [38] L. Bazinet, M. Araya-Farias, Effect of calcium and carbonate concentrations on cationic membrane fouling during electrodialysis, *Journal of Colloid and Interface Science* 281 (Jan) (2005) 188–196.

Paper II

“Sequential electro-dialytic recovery of phosphorus from ashes of low-temperature gasification of chemically precipitated sewage sludge”, Accepted in: *Waste Management*, 2016.



Contents lists available at ScienceDirect

Waste Management

journal homepage: www.elsevier.com/locate/wasman

Sequential electrodialytic recovery of phosphorus from low-temperature gasification ashes of chemically precipitated sewage sludge

Raimon Parés Viader^{a,*}, Pernille Erland Jensen^a, Lisbeth M. Ottosen^a, Jesper Ahrenfeldt^b, Henrik Huggaard-Nielsen^c

^a Department of Civil Engineering, Technical University of Denmark, Building 118, 2800 Kongens Lyngby, Denmark

^b Department of Chemical and Biochemical Engineering, Technical University of Denmark, Building 313, 4000 Roskilde, Denmark

^c Department of Environmental, People and Technology, Roskilde University, 4000 Roskilde, Denmark

ARTICLE INFO

Article history:

Received 17 August 2016

Revised 11 November 2016

Accepted 21 November 2016

Available online xxxx

Keywords:

Electrodialysis

Heavy metals

Iron phosphates

Low-temperature gasification

Phosphorus

Sewage sludge ash

ABSTRACT

Phosphorus recycling from secondary materials like sewage sludge ashes offers an alternative to mining of phosphates from primary resources and a mean to counteract the current phosphorous rock depletion concern. A separation of P from the bulk ash is normally required, due to its low plant availability and the presence of heavy metals. Previously, more than 80% of P was recovered from incineration sewage sludge ashes using a two-compartment electrodialytic cell. In contrast, the recovery was below 30% for ashes from low-temperature gasification using the same setup. The low recovery was due to a high presence of Al- and Fe(III)-P bindings. In the present study, an electrodialytic process combining sequentially a pair of two-compartment cells allowed a recovery of up to 70% of phosphorus from these ashes. The use of a second cell, where the ash was suspended in an alkaline solution, allowed the P solubilisation from aluminium and ferric phosphates. In addition, P was separated from most metals as they became insoluble under the prevailing chemical environment. The obtained ratio of Al, Fe, Mg and most heavy metals to P was comparable to wet process phosphoric acid. Therefore, this sequential process was found to be suitable to recycle P and potentially use it in the production of common fertilizers like diammonium phosphate.

© 2016 Elsevier Ltd. All rights reserved.

1. Introduction

Europe is dependent on phosphate rock imports (van Dijk et al., 2016), the reserves of which are estimated to be exhausted within 50–400 years (van Dijk et al., 2016; Cordell et al., 2009; Dawson and Hilton, 2011). The European Commission included this mineral in the list of 20 critical raw materials in 2014. Moreover, mineral P-fertilizers are the main contributors of toxic elements accumulation such as cadmium (McBride and Spiers, 2001) and uranium (Taylor, 2007) in agricultural soils. For these reasons, P recycling from secondary resources, like sewage sludge, has gained increased attention among researchers, private companies and public institutions over the last decade (Sartorius et al., 2012; Gorazda et al., 2013; Schoumans et al., 2015; Herzel, 2015). Around 16% of phosphate rock import can be potentially substituted with unrecycled P from sewage sludge in Europe (van Dijk et al., 2016). In order to promote P recycling, some countries e.g. Denmark have set goals for P recovery (Denmark without waste, 2013), and others e.g. Ger-

many, Switzerland and Sweden currently have proposals to make it obligatory. The content of heavy metals as well as potential unwanted organic pollutants and pathogens are of major concerns in respect to sewage sludge's direct use on agricultural fields (Schoumans et al., 2015; Withers and et al., 2015). Another difficulty is the limited plant-availability of P when sewage sludge is precipitated with Al and Fe salts in the wastewater treatment plant to avoid eutrophication of natural water system recipients, a practice which is common in many countries (Gorazda et al., 2013; Paul et al., 2001; Donatello et al., 2010; Rodriguez-Garcia et al., 2011; Kruger et al., 2014).

Thermal processes such as incineration (Donatello and Cheeseman, 2013) and low-temperature gasification (Thomsen et al., 2015) can lead to the removal of organic contaminants from sewage sludge, but additional treatments of the resulting sewage sludge ashes (SSA) are required to separate P from heavy metals and ensure its bioavailability (Gorazda et al., 2013; Schoumans et al., 2015; Franz, 2008; Parés Viader et al., 2015). Electrodialysis (ED) has been studied as a technique to extract P from different SSA using 2-compartment cells (Parés Viader et al., 2015; Ebberts et al., 2015). In this setup, SSA is suspended in water in the anode com-

* Corresponding author.

E-mail address: rapv@byg.dtu.dk (R. Parés Viader).

partment, which is separated from the cathode compartment by a cation exchange membrane. When applying the electric field the cations are transported from the anolyte to the catholyte through the membrane. Protons are concurrently produced from water electrolysis at the anode, which increases the solubilisation of the different elements present in the SSA (Parés Viader et al., 2015; Ebberts et al., 2015). Thus, the applied electric field results in acidic leaching combined with cation migration into the cathode compartment. Large recoveries of P (higher than 80%) have been achieved for incineration SSA (Ebberts et al., 2015) and biologically precipitated SSA from low-temperature gasification (Parés Viader et al., 2015). On the contrary, less than 26% of P was recovered from chemically precipitated SSA from the same gasification unit. The reason for the low recovery was found to be the influence of Fe (III) on P-solubility and the formation of positively charged Fe-P complexes in acidic medium (Parés Viader et al., 2015).

Other processes than ED has been investigation for the recovery of P from SSA and the majority can be grouped into either:

- (a) Acid extraction of P from SSA with H_2SO_4 , HCl, HNO_3 and/or H_3PO_4 , followed by further steps to separate P from the leached impurities like heavy metals by means of sulphide precipitation (Franz, 2008), solvent extraction (Dittrich et al., 2009) and/or ion exchange columns (Donatello et al., 2010; Franz, 2008; Lehmkuhl and Lebek, 2015a; Takhim, 2015), as well as through the chemical precipitation of P as Ca-phosphates (Herzel, 2015; Lehmkuhl and Lebek, 2015a, 2014, 2015b). The biggest industrial agreement to recycle P from SSA until now was signed in the beginning of 2015 between the Belgian company Ecophos and the Dutch companies HVC and SNB, which includes the construction of a plant to treat 50–60,000 tonnes of incineration SSA yearly using a method belonging to this group.
- (b) Thermal removal of heavy metals at high temperatures (above 1400 °C) Herzel, 2015; Schönberg et al., 2014, which also allows the separation of the main metals like Fe; or at around 1000 °C in combination with chemicals like calcium or magnesium chloride (Adam et al., 2009), Na- and K-salts and bases (Herzel, 2015; Krüger et al., 2016; Stemann et al., 2015), which at the same time increases the plant availability of P in the ashes.

However, these researches have focused on chemically precipitated incineration SSA, where Fe(III) is not controlling P solubility (Cohen, 2009; Gorazda et al., 2012), which is on the contrary to gasification SSA. An alkaline extraction step could potentially dissolve Fe(III)-phosphates (Sano et al., 2012; Wilfert et al., 2015) existing in gasification SSA, with the advantage of preventing the formation of complexes like $\text{Fe}(\text{H}_2\text{PO}_4)^{2+}$ or $\text{Fe}(\text{HPO}_4)^+$ which complicate P separation in ion exchange processes and ED (Parés Viader et al., 2015; Ottosen et al., 2014). By such treatment, alkaline-insoluble Ca-phosphates (Stumm and Morgan, 1996) would, however, not be dissolved. Instead, a common strategy to leach P from materials containing both Ca-P and Al/Fe(III)-P bonds, previously used for Al-precipitated SSA (Petzet et al., 2012, 2011), soils (Benzing and Rickardson, 2005), sediments (Ribeiro et al., 2008), and municipal solid waste fly ashes (Kalmykova and Fedje, 2013), is to solubilise the different Ca-bearing phases in an acidic step, and the Al/Fe(III)-P bindings in an alkaline step. Nevertheless, the order of execution requires an investigation. Starting with an acidic extraction can lead to P re-precipitation as Al-P (Petzet et al., 2012, 2011), and probably Fe(III)-P, which increases the hydroxide demand for their dissolution in the subsequent alkaline step. Starting with an alkaline extraction, P could re-precipitate as Ca-P or adsorb to Ca compounds (Petzet et al., 2011; Benzing and Rickardson, 2005; Chen et al., 2007), which increases the proton

demand for P dissolution in the following acidic step. In order to assess which combination is best to recover P, both possible two-stage chemical processes are compared in the present study.

Recently, a patent concerning an innovative sequential ED process (Fig. 1) has been filed with the European Patent application number 15187370.0. The new method combines two existing 2-compartment cell configurations, one with a cation exchange membrane (Parés Viader et al., 2015; Ebberts et al., 2015) and another one with an anion exchange membrane (Touaibia et al., 1996), into a sequential process. The present research focuses on achieving a higher recovery of P from low-temperature gasification SSA, which has been chemically precipitated, using a sequential ED process in comparison to a single step with a 2-compartment cell with a cation exchange membrane.

2. Experimental

2.1. Experimental SSA

The investigated SSA were the same as in previous published work (Parés Viader et al., 2015), where the ashes were collected from the second cyclone of a 100 kW experimental Low Temperature Circulating Fluid Bed gasifier (Ahrenfeldt et al., 2013) at the Department of Chemical and Biochemical Engineering in the Technical University of Denmark. The original feedstock was dried sludge collected at the wastewater treatment plant in the Randers Municipality, Denmark, where P was captured approximately 50:50 by biological and chemical means. The chemical precipitation was based on Fe and Al chlorides.

2.2. Analytical methods and sampling

Small batches of around 200 g were sampled from the total mass collected. Each batch was dried at 105 °C overnight, cooled in the fume hood, homogenised with a steel spatula and immediately stored in plastic bags under dry conditions. A different batch was used for each experiment: alkaline extraction (Batch 1), two-stage chemical extraction (Batch 2) and ED experiments (Batch 3). The CaCO_3 content in another separate batch from the same overall sample was measured following the German standard DIN 18 129 (Rothenhofer et al., 2000).

The concentrations of elements were measured for each batch: in triplicates for the alkaline extraction as well as for the sequential extraction, and in eight samples for the ED experiments. It was also measured in triplicates after each step of the sequential extraction and the ED experiments. The targeted elements were: Al, As, Ca, Cd, Cu, Cr, Fe, K, Mg, Ni, P, Pb and Zn. Na was analysed only for the initial samples of the ED experiments. Their content was measured by Varian 720-ES inductively coupled plasma optical emission spectrometry (ICP-OES) after pre-treatment by Danish Standard DS259 (Danish standard, 2003): 1 g ash and 20 mL 7.3 M HNO_3 were heated at 200 kPa (120 °C) for 30 min. The liquid was thereafter separated by vacuum filtration through a 0.45 μm filter and diluted to 100 mL with deionised (DI) water.

Element concentrations among the batches were compared through a one-way analysis of variances (ANOVA).

2.3. Alkaline extraction

In order to assess the dependence of solubility of the target elements to alkaline solutions, 5 g of ash was shaken at 150 rpm for 1 week with 25 mL of NaOH at 1, 0.5, 0.1, 0.05 and 0.01 M respectively. The pH of the leachate was measured by a Radiometer Analytical pH electrode. The concentrations of the targeted elements in

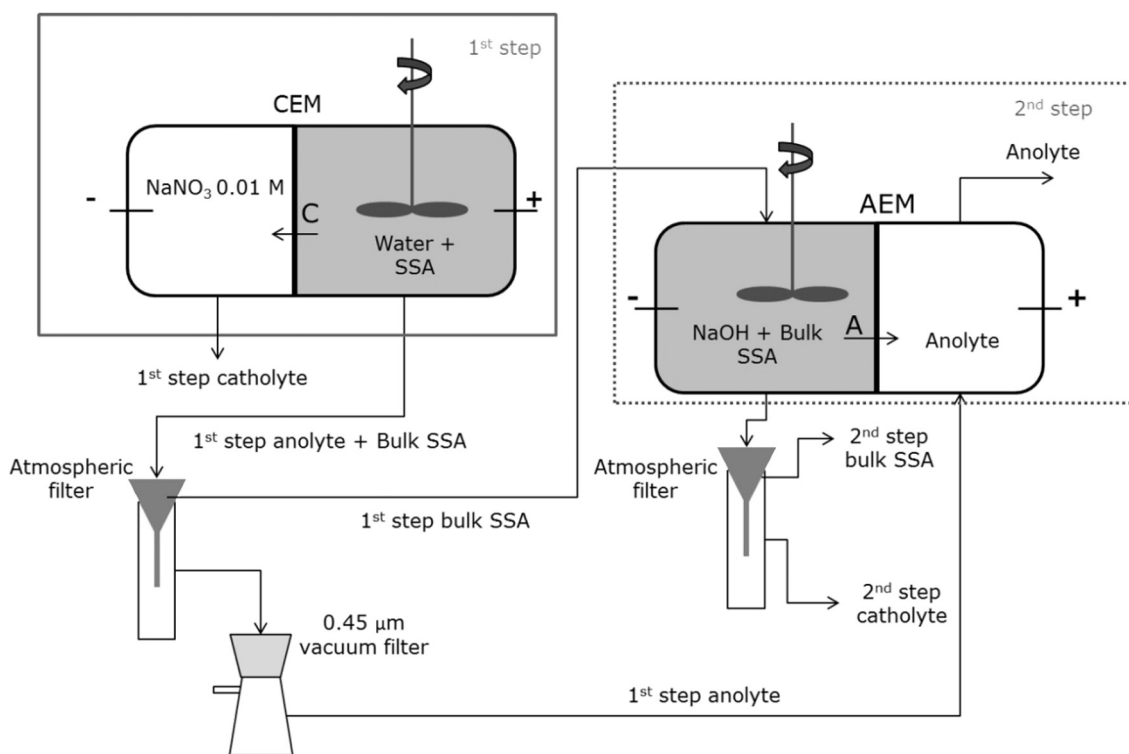

Fig. 1. Schematic view of the sequential ED process. C: cations, A: anions, CEM: Cation Exchange Membrane, AEM: Anion Exchange Membrane.

the leachate were measured by the Varian 720-ES ICP-OES after filtration through a 0.45 μm syringe filter.

2.4. Two-stage chemical extractions

Two different two-stage chemical extraction procedures were compared in order to investigate the most suitable order of the sequential P-extraction: alkaline-acid or acid-alkaline. The combined acid and base load (H^+ and OH^- moles per kg of dry ash) was equal to 5; this value was equivalent to the acid load in which almost all P could be mobilised in a previous research with the same ash (Parés Viader et al., 2015). In the alkaline-acid extraction, 10 g of ash were shaken at 150 rpm for 24 h with 50 mL of NaOH at 0.5 M; the ash suspension was filtered at atmospheric pressure, the filtrate volume and pH were measured and sampled with a 0.45 μm syringe filter, and the ash was dried during 48 h at 50 $^\circ\text{C}$. The dried ash was weighted, loosened by hand in a mortar, sampled and 5 g of it were shaken at 150 rpm for 24 h with 25 mL of HNO_3 at 0.5 M. In the acid-alkaline extraction, the same procedure was repeated starting with a step with 0.5 M HNO_3 followed by 0.5 M NaOH. All targeted elements were measured by the Varian 720-ES ICP-OES in the liquid phases at the end of each step. The amount of P, Ca, Al and Fe found in the filtrate of each step was considered to be extracted. The overall % of P extraction was calculated as:

$$\%P \text{ extraction} = \frac{P \text{ extracted in filtrates}}{\text{Total P at the end of the experiment}} = \frac{V_{\text{acid}} \cdot C_{\text{P-acid}} + V_{\text{alkaline}} \cdot C_{\text{P-alkaline}} \cdot \frac{m_{\text{ash-acid}}}{m_{\text{ash-start}}}}{V_{\text{acid}} \cdot C_{\text{P-acid}} + (V_{\text{alkaline}} \cdot C_{\text{P-alkaline}} + C_{\text{P-ash-alkaline}} \cdot m_{\text{ash-alkaline}}) \cdot \frac{m_{\text{ash-acid}}}{m_{\text{ash-start}}}}$$

where V_{acid} and V_{alkaline} were the volumes of filtrates recovered after each extraction, $C_{\text{P-acid}}$ and $C_{\text{P-alkaline}}$ the concentration of P in these filtrates, $C_{\text{P-ash-alkaline}}$ the P-concentration in the dry ash

after the alkaline extraction, whereas $m_{\text{ash-start}}$, $m_{\text{ash-acid}}$ and $m_{\text{ash-alkaline}}$ were the mass of dry ash at the beginning and at the end of each extraction. The reason for the inclusion of the ratio between $m_{\text{ash-acid}}$ and $m_{\text{ash-start}}$, multiplying the second term in the dividend and the divisor, was to extrapolate the result of the alkaline extraction step to all the bulk dry ash mass after the acid extraction. The same equation was used to calculate Ca, Al and Fe extraction.

2.5. ED experimental setup

An illustration of the ED sequential process used is shown in Fig. 1. Both cells consisted of two compartments made of cylindrical Plexiglas[®] with an internal diameter of 8 cm. The compartment with the ash suspension was 10 cm long and the other compartment was 5 cm. The anode compartment contained 35 g ash and 350 ml DI water. In the second step, the cathode compartment contained 25 g of the bulk ash resulting from the first step and 300 ml DI water, as well as 8 mL of NaOH 1 M added at the beginning of the experiment. A plastic strip attached to a glass-stick connected to an overhead stirrer (IKA RW11) was used to stir the ash suspensions during the experiments. In the cathode compartment of the first step, 500 mL electrolyte solution (0.01 M NaNO_3 , pH < 2 adjusted with HNO_3) was circulated by a Plastomec pump model P05. In the anode compartment of the second step, the anolyte

resulting from the first step was circulated using the same pump model after vacuum filtration through a 0.45 μm filter. The electrodes were made of platinum coated titanium wire (diameter

3 mm) obtained from Permacsand®. An Agilent E3612A DC power supply was used to maintain a constant DC current. The cation and anion exchange membranes used were from Ionics (model CR67 and AR204SZRA respectively).

2.6. ED experiments

Three set of sequential ED experiments were performed; the first step ran until the pH in the anolyte reached 1.5, 1.7 or 2, whereas the second step ran equally for 3 days in each experiment. The time and final pH of the SSA suspension in each ED experiment are shown in Table 1. The pH values in the first step were similar to the results of previous ED experiments with the same ash (Parés Viader et al., 2015), and the aim was to investigate their influence in the recovery of P. The intensity was 50 mA, chosen following the findings from previous researches using ED for P extraction from incinerated and gasification SSA (Parés Viader et al., 2015; Ebberts et al., 2015; Ottosen et al., 2014; Guedes et al., 2014). Voltage between the two electrodes was monitored during the whole experiment. The pH in both compartments and the conductivity of the ash suspension were measured twice a day during the ED experiments. The pH of the catholyte of the first step was adjusted to <2 with HNO₃ 5M, to avoid precipitations due to the production of OH⁻ by the electrode reaction at the inert cathode.

At the end of each step, the ash suspension was filtered at atmospheric pressure, and after the first step the ash was flushed with 200 mL of DI water in order to displace the elements in solution retained in the humidified ash. The resulting liquid volume was measured, and the ash was dried during 48 h at 50 °C. The dried ash was loosened by hand in a mortar and stored in plastic bags under dry conditions. The electrodes were rinsed in 5 M HNO₃, the membranes in 1 M HNO₃, and the concentrations of the elements were measured in all of the liquids by ICP-OES after filtration through a 0.45 µm syringe filter.

Catholyte (in the first step) and anolyte (in the second step) samples were taken in 20 mL vials before applying the electrical current and after 5 min of electrolyte circulation; at the end of the experiments, catholyte and anolyte volumes were measured and sampled in 20 mL vials. 16 mL of the samples from the catholyte in the 2nd step was mixed with 4 mL HNO₃ 68%, and heated at 200 kPa (120 °C) for 30 min. The element content was measured in the ICP-OES for all electrolytes after filtration through a 0.45 µm syringe filter. Na content in the catholyte of the second step was also measured by ICP-OES.

2.7. Experimental ED parameters

The ED experiments were evaluated in terms of rates of P recovery and the impurity level of the obtained product.

The amounts of P found in the anolyte of the 1st and 2nd steps were considered as recovered, since they were expected to be solutions rich in this element and depleted of impurities like metallic cations. The overall % of P recovered was calculated as:

$$\% P \text{ recovery} = \frac{P \text{ in anolytes}}{\text{Total P at the end of the experiment}}$$

Table 1
Final pH in the SSA suspensions and duration of each step in the ED experiments.

| Experiment | ED step | Final pH | Duration [h] |
|------------|-----------------|----------|--------------|
| A | 1 st | 1.5 | 125 |
| | 2 nd | 11.6 | 72 |
| B | 1 st | 1.7 | 52.5 |
| | 2 nd | 12.2 | 72 |
| C | 1 st | 2.0 | 27.5 |
| | 2 nd | 12.2 | 72 |

And the amount of P in the anolytes was calculated as:

$$V_{1^{st} \text{ step}} \cdot C_{P-1^{st} \text{ step}} + V_{2^{nd} \text{ step}} \cdot C_{P-2^{nd} \text{ step}} \cdot \frac{m_{\text{ash}-1^{st} \text{ step}}}{m_{\text{ash}-2^{nd} \text{ step-start}}}$$

where $V_{1^{st} \text{ step}}$ and $V_{2^{nd} \text{ step}}$ were the volumes of anolyte at the end of each step, $C_{P-1^{st} \text{ step}}$ and $C_{P-2^{nd} \text{ step}}$ the concentration of P in the anolytes for each ED step, whereas $m_{\text{ash}-1^{st} \text{ step}}$ and $m_{\text{ash}-2^{nd} \text{ step-start}}$ were the mass of dry ash at the end of the 1st step and at the beginning of the 2nd step, respectively. The inclusion of the ratio between $m_{\text{ash}-1^{st} \text{ step}}$ and $m_{\text{ash}-2^{nd} \text{ step-start}}$ multiplying the second term was used to extrapolate the result of the 2nd ED step to all the bulk dry ash mass after the 1st step.

In order to assess the amount of impurities in the recovered P, it was compared to wet process phosphoric acid (WPA), the product of leaching phosphate rock with sulphuric acid (Gilmour, 2014) which is applied to over 70% of mined phosphates (Scholz et al., 2014). A common parameter to evaluate the suitability of WPA in the fertilizer industry is the minor element ratios (MER), defined as:

$$MER = \frac{\text{Fe}_2\text{O}_3 + \text{Al}_2\text{O}_3 + \text{MgO}}{\text{P}_2\text{O}_5}$$

Additionally, the amount of P bound to Ca and Al/Fe(III) in the bulk SSA at the beginning and at the end of the 2nd step were estimated by:

- Considering all remaining Ca to be bound to P according to the stoichiometry of Ca₃(PO₄)₂. This implied an overestimation of these bindings, since there could be other Ca compounds not containing P, but it gave an overview of the effectiveness of the sequential ED method.
- Considering all P not bound to Ca, in the previous point, to be bound to Al or Fe(III).
- In both cases, average concentrations of Ca and P in the bulk SSA were used.

3. Results

3.1. Element content in untreated SSA

The element concentrations in the three batches used are shown in Table 2, together with the results for a batch from a previous research on ED treatment of the same SSA (Parés Viader et al., 2015). After performing an ANOVA with a P-value >0.05, average values were the same for the batches used in the ED treatment (Batch 3 and from Parés Viader et al. (2015)) for Al, Ca, Fe, P, Cr, Cu, Ni, Pb and Zn. In contrast, Ca, P, Pb and Zn average contents were different between Batches 1 and 3. Mean concentrations for Al, Fe, P, Cr, Ni and Zn were also different between Batches 2 and 3. These differences, together with the standard deviation in elements like Ca, Fe and P in Batches 2 and 3, show a relatively high degree of the inhomogeneity of these SSA and demand a rather qualitative comparison of the results of the different experiments.

3.2. Alkaline and two-stage chemical extractions

The solubility of all studied elements increased with the increase of pH except for Ca. Desorption of Fe, Cr, Cu, Zn was generally below 0.05%, and the highest desorbed percentage of these being 0.5% for Zn at pH 13.3. The concentrations of Cd and Pb were below the limit of detection (LOD), 0.02 mg/L, in all alkaline leaching experiments. Solubilised percentages of As are not included due to the inhomogeneity of its concentration in the ashes, with some results below LOD (Table 2); however, the results show a high degree of solubilisation, equivalent to 0.6, 1.6 and 3.0 mg/kg of drySSA at pH 11.5, 13.0 and 13.3, respectively. Fig. 2 shows

Table 2

Element concentration (average \pm standard deviation) of untreated SSA from different batches analysed by ICP, after digestion following Danish Standard DS259 (Danish standard, 2003).

| Element | Previous research (Parés Viader et al., 2015) | Batch 1 – Alkaline extraction | Batch 2 – Two-stage chemical extraction | Batch 3 – ED | | Units |
|---------|---|-------------------------------|---|----------------------|-----------------------|-------|
| | per kg of dry ash | | | per kg of P | | |
| Al | 9.5 \pm 1.3 | 11.6 \pm 0.5 | 14.9 \pm 3.9 | 10.5 \pm 1.2 | – | g/kg |
| Ca | 36.7 \pm 5.1 | 40.4 \pm 0.6 | 51.9 \pm 10.7 | 34.3 \pm 4.4 | – | g/kg |
| Fe | 57.6 \pm 8.3 | 58.3 \pm 2.9 | 82.6 \pm 21.1 | 58.3 \pm 6.7 | – | g/kg |
| Mg | – | 3.0 \pm 0.6 | 3.7 \pm 0.9 | 3.4 \pm 0.4 | – | g/kg |
| P | 32.4 \pm 4.6 | 38.7 \pm 2.3 | 49.3 \pm 11.8 | 30.0 \pm 3.6 | – | g/kg |
| As | – | <2 ^a | <2 ^a –4 | <2 ^a –4.4 | <67 ^a –133 | mg/kg |
| Cd | <2 ^a –3.14 | 3.7 \pm 0.3 | <2 ^a | <2 ^a | <67 ^a | mg/kg |
| Cr | 34 \pm 3.8 | 36.8 \pm 2.3 | 42.3 \pm 9.8 | 34.8 \pm 3.3 | 1160 | mg/kg |
| Cu | 160 \pm 21 | 180 \pm 14 | 200 \pm 54.7 | 165 \pm 16.2 | 5490 | mg/kg |
| Ni | 28 \pm 1.6 | 33.3 \pm 1.0 | 36.7 \pm 4.7 | 30.1 \pm 3.1 | 1000 | mg/kg |
| Pb | 37 \pm 6.7 | 47.7 \pm 5.2 | 52.1 \pm 17.9 | 40.5 \pm 4.2 | 1350 | mg/kg |
| Zn | 1000 \pm 130 | 1630 \pm 88 | 1680 \pm 41 | 1000 \pm 109 | 33,400 | mg/kg |

^a Below ICP LOD.

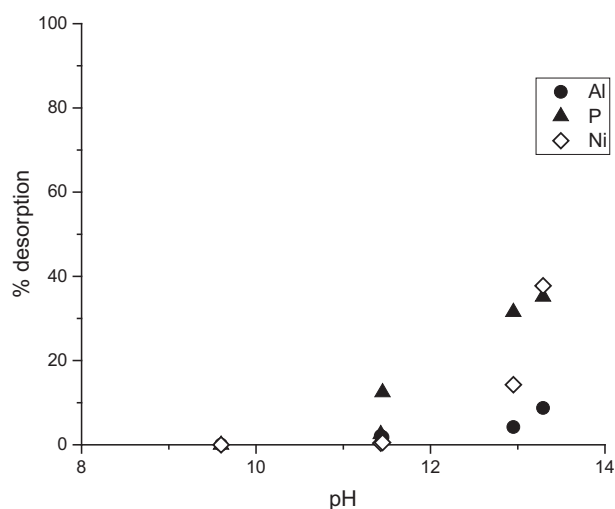

Fig. 2. Alkaline extraction of Al, Ni P in the SSA.

the results for Al, P and Ni, as the most remarkable results, as they are well above 5% in at least one of the alkaline extractions.

P solubilisation results in Fig. 2 confirms the existence of alkaline-soluble Fe(III)-P (and/or Al-P) bonds in these ashes, as previously suggested for the same SSA (Parés Viader et al., 2015). P extraction using 1 M NaOH was 35%, considerably lower than the result of using 1 M HNO₃, which was 96% in the previous work with the same material (Parés Viader et al., 2015). This unsymmetrical leaching behaviour of an individual acid and alkaline extraction step was previously reported for chemically precipitated incineration SSA (Petzet et al., 2012; Biswas et al., 2009). There are mainly two explanations for this asymmetry. First, the presence of Ca-phosphates, which are acid-soluble but alkaline-insoluble; in contrast, Fe- or Al- phosphates are soluble at both highly acidic and alkaline conditions (Stumm and Morgan, 1996). Second, P can simultaneously be adsorbed or re-precipitate in the presence of calcium compounds e.g. CaCO₃ (these SSA contained 1.14 \pm 0.14% CaCO₃), CaO and CaSO₄ at alkaline pH (Petzet et al., 2011; Benzing and Rickardson, 2005; Chen et al., 2007). As a consequence, it is not possible to determine accurately the predominance of each bond (Ca-, Fe(III)- and/or Al-phosphate). The reason for the low solubility of Fe in the alkaline extraction (4.4 \cdot 10⁻⁵ M at pH 13.0) is most likely due to re-precipitation of the solubilised Fe(III), previously bound to P, to hydroxides, for which the solubility are around 10⁻⁴ M at pH 13 (Gilmour, 2014).

An acidic step followed by an alkaline extraction allowed an extraction of up to 81% of P (Table 3). This high percentage is pos-

sibly due to the removal of over 90% of Ca in the acidic step (Table 3), so that most Ca-P bindings are dissolved and Al/Fe(III)-P bindings (more soluble at pH \sim 11–12 than at pH \sim 1.5 (Stumm and Morgan, 1996) are broken in the subsequent alkaline step without Ca compounds interference. In contrast, only 36% of P was extracted following the opposite order (Table 3). Since most Ca was removed in the acidic step (Table 3), this poor result can be due to the formation of acid-soluble Fe(III) and/or Al solids in the alkaline step (i.e. hydroxides) and subsequent re-precipitation of P with Al and/or Fe(III) in the acidic step. Then, the ideal order for P recovery from these SSA is to use an acidic step followed by an alkaline step, as previously found for incineration SSA, where P has been precipitated with Al salts during the waste water treatment (Petzet et al., 2012, 2011). In the alkaline step of this sequence, most P was extracted whereas all metals leached at low rate (Table 3, <1% for the rest), except for As leaching, which was equivalent to 2.2 mg/kg of dry SSA, representing at least a 50% of As content in Batch 3 (Table 2). Thus, this combination can also potentially separate P from most metals. Since results in Table 3 are obtained without running two or more replicates, they are used as an orientation and not for numerical comparisons in the next sections.

3.3. ED experiments

In a two-compartment ED cell, pH of the water and SSA suspension decreased when placed in the anode compartment, or increased if placed in the cathode compartment due to water electrolysis at the electrodes. Thus, an acid-alkaline sequential extraction can be adapted in an ED process connecting a couple of 2-compartment ED cells (Fig. 1).

3.3.1. Element distribution and mass balances

The element distribution in the different compartments at the end of the experiments was determined, considering that:

- The catholyte, the cathode and the cation exchange membrane were grouped as the cathode compartment in the 1st step.
- The total mobilisation or desorption of each element, including P, was the sum of the masses found in all electrolyte solutions, membranes and electrodes at the end of the experiments.
- The amount of each element migrated to the catholyte in the 1st step, and to the anolyte in the 2nd step was defined as the difference in each element amount in the electrolyte solution at the end minus at the start of the step.
- The amounts of each element found at the anode in all ED experiments were always below 0.2% of the initial content in

Table 3
Final pH and percentage of element extracted to the filtrates in the two-stage chemical extractions.

| Element | Alkaline-acid extraction | | | Acid-alkaline extraction | | |
|----------|--------------------------|-----------|--------------------|--------------------------|---------------|--------------------|
| | Alkaline step | Acid step | Overall extraction | Acid step | Alkaline step | Overall extraction |
| P | 26% | 15% | 36% | 30% | 73% | 81% |
| Ca | 0% | 91% | 91% | 92% | 0% | 91% |
| Al | 6% | 16% | 21% | 17% | 0% | 18% |
| Fe | 0% | 1% | 1% | 16% | 0% | 17% |
| Final pH | 13.2 | 1.7 | – | 1.5 | 11.7 | – |

the untreated SSA. In consequence, their results are not shown in detail in the present work.

Mass balances for each element (except Cd and As), defined as the division of the amount found at the end of the experiments by the mass initially found in the initial SSA placed in the ED cell, were made to control the quality of each step of the experiments. Most mass balances varied between 80% and 120%, which is probably due to the inherent inhomogeneity of the SSA (Table 2 and Section 3.1). Concentration measurements which were below the LOD used in the ICP analyses (0.02 mg/L), were considered to have this value, except for the anodes and the 1st step catholyte prior to applying the electrical current which were considered to be zero. This arrangement affected several measurements in the cathode compartments for Cr, Cu, Ni and Pb and, together with Cd, in the anolytes. The reason was to be able to calculate the mass balances and the worst-case value for other important parameters in the present work like the heavy metal to P ratio in the anolytes. The overall impact of these approximations was small: below 2.5% of the total final element mass found at the end of the ED experiments.

3.3.2. Evolution of ED cell voltage, ash suspension pH and conductivity

The voltage between the two electrodes decreased during both steps of the three sets of ED experiments, which corresponded to an increase in electrical conductivity, as well as the pH decrease (1st step) or increase (2nd step) of the SSA suspension. This is due to the increase of ionic concentration in all electrolyte solutions by the generation of either protons (1st step) or hydroxides (2nd step) at the electrodes, as well as the desorption of the elements from the SSA with the changes in pH. Moreover, the rise in conductivity discards possible fouling in the ion exchange membranes (Araya-Farias and Bazinet, 2006). The final pH values of each step are seen in Table 1.

3.3.3. P-recovery: 1st and 2nd step

Fig. 3 shows the distribution of P at the end of the sequential ED experiments. The amount of P in the 1st step anolyte increased with the time of remediation: 126, 239 and 294 mg P (Fig. 3) after 27.5, 52.5 and 125 h (Table 1). This is consistent with the previous results with the same SSA (Parés Viader et al., 2015), where the recovered amounts are calculated to be 147, 261 and 295 mg of P after 24, 72 and 168 h, respectively. Therefore, no big differences were observed above 72 h of ED experiments in terms of P recovery (below 15%), despite the much longer treatment. This can be explained by the low solubility of Fe(III)-phosphates at acidic pH (Stumm and Morgan, 1996), and the higher P migration towards the cathode with longer treatments (Fig. 3, and Parés Viader et al., 2015), due to the formation of positively charged Fe-P and Al-P complexes. Therefore, a higher recovery cannot be expected with a longer duration of a single ED stage using the configuration of the 1st step.

Around 6–8 g of the bulk SSA resulting from the first step were not treated in the second step, because a part of it (3 g) was used for sampling and the rest could not be recovered from the filter paper. The corresponding amounts of P are shown in Fig. 3 as “Bulk

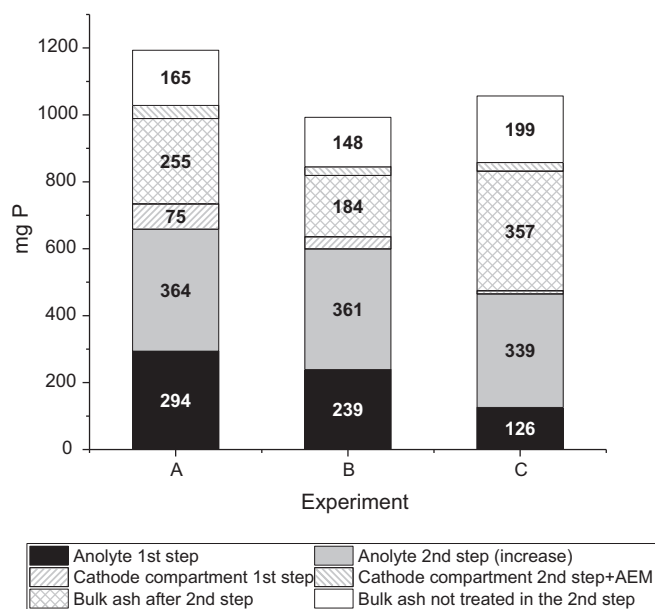

Fig. 3. P distribution at the end of ED experiments.

ash not treated in the 2nd step”. Despite that, a higher amount of P was recovered to the anolyte in the 2nd step compared to the 1st step for all three experiments (Fig. 3), which is consistent with the results of the second step of the acid-alkaline extraction (Table 3).

As seen, a lower pH in the first step (Table 1) implied a higher recovery of P mass in the anolytes (Fig. 3). The amounts of P recovered in the 2nd step (Fig. 3) were similar (~350 mg) for the three experiments, and below the estimated amount of P bound to Fe(III)/Al in the bulk SSA at the beginning of this step (Table 4). In fact, Fe(III)- or Al-P bindings would still be predominant in the bulk ash at the end of experiments A and B (Table 4). Considering a valence of three, 350 mg of P represent a transport number of around 0.25 in the 2nd step. A reason for this low migration can be a low solubilisation in the cathode compartment, as a higher amount of P was bound to Fe(III) or Al in the ashes (Table 4) than found in the cathode compartment at the end of the 2nd step (Fig. 3). In order to increase P mobilisation from these SSA, longer remediation times or higher initial NaOH concentrations could be used, although it requires further study.

The total mass of P recovered in experiment B was 600 mg (Fig. 3), with a total remediation time of 124.5 h. This amount doubled the results of running only the 1st ED step for 125 h (1st step of experiment A) and 168 h (see the beginning of this section), even though not all bulk SSA was used in the 2nd step, and confirms its potential to treat these SSA. P-recoveries in experiments A, B and C were 62, 70 and 54%, respectively. The reason for the lower % P-recovery in experiment A than B, despite a higher amount of P recovered, is primarily due to the higher content of P in the initial ash (Fig. 3).

Table 4Estimation of mg of average P bound to Ca or Al/Fe(III) in the bulk SSA at the end of the 1st and the 2nd ED step.

| mg P bound to | At the end of the 1 st step | | | At the end of the 2 nd step | | |
|---------------|--|-----|-----|--|----|-----|
| | A | B | C | A | B | C |
| Ca | 78 | 119 | 197 | 74 | 84 | 213 |
| Al/Fe(III) | 658 | 468 | 436 | 180 | 99 | 144 |

Table 5

Chemical composition of the analyte solutions in each step of the ED experiments. MER values exceeding 0.085, and metal to P ratios exceeding the values in WPA (Gilmour, 2014) are shown in bold.

| Parameter | Experiment | | | | | | WPA (Gilmour, 2014) | Units |
|-----------|--------------------------|--------------------------|--------------------------|----------------------|--------------------------|--------------------------|---------------------|---------|
| | A | | B | | C | | | |
| | 1 st step | 2 nd step | 1 st step | 2 nd step | 1 st step | 2 nd step | | |
| P content | 0.03 | 0.02 | 0.50 | 1.32 | 0.25 | 1.01 | ~340–450 | g P/L |
| Al/P | 0.15 | 0.05 | 0.02 | 0.02 | 0.02 | 0.03 | <0.03 | kg/kg P |
| Fe/P | 0.02 | 0.01 | 0.06 | 0.02 | 0.02 | 0.01 | <0.04 | |
| Mg/P | 0.07 | 0.04 | 0.02 | 0.01 | 0.05 | 0.01 | 0.01–0.03 | |
| MER | 0.13 | 0.05 | 0.06 | 0.04 | 0.07 | 0.04 | – | – |
| As/P | 94 | 108 | <40 ^a | 139 | 159 | 117 | 20–70 | mg/kg P |
| Cd/P | <31 ^a | <11 ^a | <40 ^a | <15 ^a | <80 ^a | <20 ^a | 120–500 | |
| Cr/P | <31 ^a | 14 | <40 ^a | <15 ^a | <80 ^a | <20 ^a | 100–3000 | |
| Cu/P | 683 | 250 | 491 | 150 | 627 | 42 | 10–400 | |
| Ni/P | 64 | 22 | <40 ^a | <15 ^a | 93 | 21 | 100–700 | |
| Pb/P | < 31 ^a | < 11 ^a | < 40 ^a | 48 | < 80 ^a | < 20 ^a | <4 | |
| Zn/P | 2200 | 746 | 1970 | 834 | 4270 | 1070 | 100–10,000 | |

^a Below LOD in ICP-OES.

3.3.4. Characterisation of the recovered P-rich liquid

The P concentrations in the analyte after the 2nd step were 1.7, 1.3 and 1.0 g/L for A, B and C respectively (Table 5), higher than the results previously achieved with a single ED step of the same SSA (0.5–0.9 g P/L Parés Viader et al., 2015). Nevertheless, these values are far below concentrations of commercial phosphoric acid (around 450 g P/L Parés Viader et al., 2015) or WPA (above 340 g P/L Gilmour, 2014), which needs to be addressed in future studies. For the three experiments, MER were lower in the analyte after the 2nd than after the 1st step (Table 5): 0.05, 0.04 and 0.04 at the end of experiments A, B and C respectively. These values were below the limit for WPA (0.085) to be used in the production of diammonium phosphate (DAP Gilmour, 2014), the most commonly traded fertilizer in the world according to the International Fertilizer Industry Association. Moreover, individual Al, Fe and Mg ratios to P were below or in the range of WPA values for all experiments, except for Fe/P in experiment A (Table 5).

Similarly to the acid-alkaline extraction (Section 3.2), the high pH in the 2nd step enabled an effective separation of P and most heavy metals. As it can be seen in Table 5, the heavy metal to P ratio in the analyte at the end of each experiment decreased in comparison to the analyte in the 1st step for some of the elements: Cu, Zn in all experiments, Ni in experiments A and C, Cr in experiment A and As in experiment C; As/P increased in experiments A and B, whereas Pb/P increased in experiment B. The rest of heavy metals concentrations were below LOD after the 2nd step, and therefore it cannot be concluded if they were decreased or increased in relation to the 1st step. The values eventually achieved in all experiments for Cr, Cu, Ni, Pb and Zn were at least an order of magnitude below the initial SSA (calculated from Table 2) and, except for Pb (which were below LOD), in the range or below the values found in WPA (Gilmour, 2014). The arsenic ratio in the solutions was in the range 108–139 mg As/kg P, similar to the highest value in the range of the untreated SSA (133 mg As/kg P, calculated from Table 2). This can be explained by its similar ionic form to PO₄³⁻ once extracted from the bulk SSA in the 2nd ED step: MINTEQA calculations with the concentrations and pH of the catholyte at the

end of each 2nd step indicate a high predominance of arsenate (AsO₄³⁻). This must be taken into account in future research addressing ED recovery of P from SSA with higher concentration in As.

4. Conclusions

In the present work, up to 70% of P was recovered from low-temperature gasification SSA using an innovative ED sequential process. The SSA had a high proportion of Fe(III)-P bindings. The result is a considerable improvement for extraction of P from these SSA compared to treatment in a single 2-compartment ED cell, where the recovery was less than 30%.

Phosphorus was effectively separated from Al, Ca, Fe, Mg and most heavy metals. This was partially due to the alkaline pH of the ash suspension in one of the steps of the ED treatment, where P bound to Fe(III) and/or Al was extracted and most metals were insoluble. The final product was an acidic P-solution with a metal content comparable to WPA, and a combined impurity level of Al, Fe and Mg suitable for the manufacturing of DAP, the most commonly trade mineral fertilizer. Future studies need to investigate different alternatives to remove arsenic as well as to increase the concentration in the final P-product.

Acknowledgements

The Energy Technology Development and Demonstration Program, Danish Ministry of Climate, Energy and Buildings is acknowledged for funding this research as part of the project “Fuel Flexible, Efficient and Sustainable Low Temperature Biomass Gasification”.

References

- Adam, C., Peplinski, B., Michaelis, M., Kley, G., Simon, F.G., 2009. Thermochemical treatment of sewage sludge ashes for phosphorus recovery. *Waste Manage.* 29 (3), 1122–1128.

- Ahrenfeldt, J., Thomsen, T., Henriksen, U.B., Clausen, L.R., 2013. Biomass gasification cogeneration – a review of state of the art technology and near future perspectives. *Appl. Therm. Eng.* 50 (2), 1407–1417.
- Araya-Farías, M., Bazinet, L., 2006. Effect of calcium and carbonate concentrations on anionic membrane fouling during electro dialysis. *J. Colloid Interface Sci.* 296 (1), 242–247.
- Benzing, P., Rickardson, C.J., 2005. CaCO₃ causes underestimation of NaOH extractable phosphorus in sequential fractionations. *Soil Sci.* 170 (10), 802–809.
- Biswas, B.K., Inoue, K., Harada, H., Ohto, K., Kawakita, H., 2009. Leaching of phosphorus from incinerated sewage sludge ash by means of acid extraction followed by adsorption on orange waste gel. *J. Environ. Sci.* 21 (12), 1753–1760.
- Chen, J., Kong, H., Wu, D., Chen, X., Zhang, D., Sun, Z., 2007. Phosphate immobilization from aqueous solution by fly ashes in relation to their composition. *J. Hazard. Mater.* 139 (2), 293–300.
- Cohen, Y., 2009. Phosphorus dissolution from ash of incinerated sewage sludge and animal carcasses using sulphuric acid. *Environ. Technol.* 30 (11), 1215–1226.
- Cordell, D., Drangert, J.O., White, S., 2009. The story of phosphorus: global food security and food for thought. *Glob. Environ. Change-Human Policy Dimens., Rev.* 19 (2), 292–305.
- Danish standard, 2003. DS259: Determination of metals in water, sludge and sediments - General guidelines for determination by atomic absorption spectrophotometry in flame.
- Dawson, C.J., Hilton, J., 2011. Fertiliser availability in a resource-limited world: Production and recycling of nitrogen and phosphorus. *Food Policy* 36, S14–S22.
- Denmark without waste, 2013. The Danish Government.
- Dittrich, C., Rath, W., Montag, D., Pinnekamp, J., 2009. Phosphorus recovery from sewage sludge ash by a wet-chemical process. In: Presented at the International Conference on Nutrient Recovery from Wastewater Streams.
- Donatello, S., Cheeseman, C.R., 2013. Recycling and recovery routes for incinerated sewage sludge ash (ISSA): a review. *Waste Manage., Rev.* 33 (11), 2328–2340.
- Donatello, S., Tong, D., Cheeseman, C.R., 2010. Production of technical grade phosphoric acid from incinerator sewage sludge ash (ISSA). *Waste Manage.* 30 (8–9), 1634–1642.
- Ebberts, B., Ottosen, L.M., Jensen, P.E., 2015. Comparison of two different electro dialytic cells for separation of phosphorus and heavy metals from sewage sludge ash. *Chemosphere*.
- Franz, M., 2008. Phosphate fertilizer from sewage sludge ash (SSA). *Waste Manage.* 28 (10), 1809–1818.
- Gilmour, R., 2014. *Phosphoric Acid Purification, Uses, Technology, and Economics*. CRC Press (Taylor & Francis Group).
- Gorazda, K., Kowalski, Z., Wzorek, Z., 2012. From sewage sludge ash to calcium phosphate fertilizers. *Pol. J. Chem. Technol.* 14 (3), 54–58.
- Gorazda, K., Wzorek, Z., Tarko, B., Nowak, A.K., Kulczycka, J., Henclik, A., 2013. Phosphorus cycle - possibilities for its rebuilding. *Acta Biochim. Pol.* 60 (4), 725–730.
- Guedes, P., Couto, N., Ottosen, L.M., Ribeiro, A.B., 2014. Phosphorus recovery from sewage sludge ash through an electro dialytic process. *Waste Manage.* 34 (5), 886–892.
- Herzel, H., 2015. Technical comparison on the design, operation and performances of ash processes - deliverable D 4.1 of the P-REX project. BAM.
- Kalmykova, Y., Fedje, K.K., 2013. Phosphorus recovery from municipal solid waste incineration fly ash. *Waste Manage.* 33 (6), 1403–1410.
- Kruger, O., Grabner, A., Adam, C., 2014. Complete survey of German sewage sludge ash. *Environ. Sci. Technol.* 48 (20), 11811–11818.
- Krüger, O., Adam, C., Hermann, L., Herzel, H., 2016. Sewage sludge ash - a promising secondary phosphorus source for fertilizer production. *Sci. Total Environ.* 542, 1136–1143.
- Lehmkuhl, J., Lebek, M., 2014. Extracting precipitates of calcium nitrate, calcium phosphate, calcium sulfate or aluminum hydroxophosphate from phosphate-containing ash from waste incineration plants, comprises extracting e.g. calcium phosphate and calcium nitrate. Patent DE102013018650-B3; WO2015067328-A1.
- Lehmkuhl, J., Lebek, M., 2015a. Purifying crude phosphoric acid, comprises reacting crude phosphoric acid with ash, calcium hydroxide and at least one sulfide, and depositing the acid-insoluble portion of the solids to obtain a filtrate or eluate. Patent DE102014006278-B3; WO2015165481-A1.
- Lehmkuhl, J., Lebek, M., 2015b. Recovering precipitates including e.g. calcium nitrate from phosphate-containing solids, comprises e.g. reacting solids with e.g. nitric acid or phosphoric acid, and adding calcium oxide or calcium carbonate to filtrate or supernatant. Patent DE102013018652-A1.
- McBride, M.B., Spiers, G., 2001. Trace element content of selected fertilizers and dairy manures as determined by ICP-MS. *Commun. Soil Sci. Plant Anal.* 32 (1–2), 139–156.
- Ottosen, L.M., Jensen, P.E., Kirkelund, G.M., 2014. Electro dialytic separation of phosphorus and heavy metals from two types of sewage sludge ash. *Sep. Sci. Technol.* 49 (12), 1910–1920.
- Paul, E., Laval, M.L., Sperandio, M., 2001. Excess sludge production and costs due to phosphorus removal. *Environ. Technol.* 22 (11), 1363–1371.
- Petzet, S., Peplinski, B., Bodkhe, S.Y., Cornel, P., 2011. Recovery of phosphorus and aluminium from sewage sludge ash by a new wet chemical elution process (SESAL-Phos-recovery process). *Water Sci. Technol.* 64 (3), 693–699.
- Petzet, S., Peplinski, B., Cornel, P., 2012. On wet chemical phosphorus recovery from sewage sludge ash by acidic or alkaline leaching and an optimized combination of both. *Water Res.* 46 (12), 3769–3780.
- Ribeiro, D.C., Martins, G., Nogueira, R., Cruz, J.V., Brito, A.G., 2008. Phosphorus fractionation in volcanic lake sediments (Azores, Portugal). *Chemosp., Chemosp.* 70 (7), 1256–1263.
- Rodriguez-Garcia, G., Molinos-Senante, M., Hospido, A., Hernandez-Sancho, F., Moreira, M.T., Feijoo, G., 2011. Environmental and economic profile of six typologies of wastewater treatment plants. *Water Res.* 45 (18), 5997–6010.
- Rothenhofer, P., Huber, A., Kainzmaier, B., Wohnlich, S., Peiffer, S., 2000. Ein Vergleich von vier Methoden zur Bestimmung des Karbonatgehaltes. A comparison of four methods for determining carbonate contents. *Wasser Und Boden, Wasser Boden, Wasser Und Boden Zeitschrift Fuer Die Gesamte Wasserwirtschaft* 52 (10), 37–42 (in German).
- Sano, A., Kanomata, M., Inoue, H., Sugiura, N., Xu, K.-Q., Inamori, Y., 2012. Extraction of raw sewage sludge containing iron phosphate for phosphorus recovery. *Chemosphere* 89 (10), 1243–1247.
- Sartorius, C., von Horn, J., Tettenborn, F., 2012. Phosphorus recovery from wastewater-expert survey on present use and future potential. *Water Environ. Res.* 84 (4), 313–322.
- Scholz, R.W., Roy, A.H., Hellums, D.T., 2014. *Sustainable Phosphorus Management: A Global Transdisciplinary Roadmap*. Springer.
- Schönberg, A., Samiei, K., Kern, H., Raupenstrauch, H., 2014. Der RecoPhos-Prozess – Rückgewinnung von Phosphor aus Klärschlammasche. The recophos process: recovering phosphorus from sewage. *Osterreichische Wasser- Und Abfallwirtschaft* 66 (11–12), 403–407.
- Schoumans, O.F., Bouraoui, F., Kabbe, C., Oenema, O., van Dijk, K.C., 2015. Phosphorus management in Europe in a changing world. *Ambio* 44, S180–S192.
- Stemann, J., Adam, C., Peplinski, B., 2015. Thermochemical treatment of sewage sludge ash with sodium salt additives for phosphorus fertilizer production - analysis of underlying chemical reactions. *Waste Manage.* 45.
- Stumm, W., Morgan, J.J., 1996. *Aquatic Chemistry : Chemical Equilibria and Rates in Natural Waters*. Wiley.
- Takhim, M., 2015. Method for recovering ash from waste incineration. Patent WO2015091946-A1.
- Taylor, M.D., 2007. Accumulation of uranium in soils from impurities in phosphate fertilizers. *LANDBAUFORSCHUNG VOLKENRODE* 57 (2), 133–139.
- Thomsen, T.P., Ravenni, G., Holm, J.K., Ahrenfeldt, J., Hauggaard-Nielsen, H., Henriksen, U.B., 2015. Screening of various low-grade biomass materials for low temperature gasification: method development and application. *Biomass Bioenergy* 79, 128–144. 8// 2015.
- Touaibia, D., Kerdjoudj, H., Cherif, A.T., 1996. Concentration and purification of wet industrial phosphoric acid by electro-electro dialysis. *J. Appl. Electrochem.* 26 (10), 1071–1073.
- van Dijk, K.C., Lesschen, J.P., Oenema, O., 2016. Phosphorus flows and balances of the European Union Member States. *Sci. Total Environ.* 542, 1078–1093.
- Parés Viader, R., Jensen, P.E., Ottosen, L.M., Ahrenfeldt, J., Hauggaard-Nielsen, H., 2015. Electro dialytic extraction of phosphorus from ash of low-temperature gasification of sewage sludge. *Electrochim. Acta* 181, 100–108.
- Wilfert, P., Kumar, P.S., Korving, L., Witkamp, G.-J., van Loosdrecht, M.C.M., 2015. The relevance of phosphorus and iron chemistry to the recovery of phosphorus from wastewater: a review. *Environ. Sci. Technol.* 49 (16), 9400–9414.
- Withers, P.J.A. et al., 2015. Stewardship to tackle global phosphorus inefficiency: the case of Europe. *Ambio* 44, S193–S206.

Paper III

“Comparison of phosphorus recovery from incineration and gasification sewage sludge ash, Accepted in: *Water Science and Technology*, 2016.

Comparison of phosphorus recovery from incineration and gasification sewage sludge ash

Raimon Parés Viader*, Pernille Erland Jensen*, Lisbeth M. Ottosen*, Tobias P. Thomsen**, Jesper Ahrenfeldt**, Henrik Hauggaard-Nielsen***

* Department of Civil Engineering, Technical University of Denmark, Building 118, 2800 Kongens Lyngby, Denmark (E-mail: rapv@byg.dtu.dk)

** Department of Chemical and Biochemical Engineering, Building 313, Technical University of Denmark, 4000 Roskilde, Denmark

*** Department of Environmental, Social and Spatial Change, Roskilde University, 4000 Roskilde, Denmark

KEYWORDS: Electrodialysis, Heavy metals, Incineration, Low-temperature gasification, Phosphorus, Sewage sludge ash

ABSTRACT

Incineration of sewage sludge is a common practice in many western countries. Gasification is an attractive option because of its high energy efficiency and flexibility in the usage of the produced gas. However, they both unavoidably produce sewage sludge ashes, a material which is rich in phosphorus, but that it is commonly landfilled or used in construction materials. With current uncertainty in phosphate rock supply, phosphorus recovery from sewage sludge ashes has become interesting. In the present work, ashes from incineration and gasification of the same sewage sludge were compared in terms of phosphorus extractability using electro-dialytic methods. The results show that comparable recovery rates of phosphorus were achieved with a single electro-dialytic step for incineration ashes and a sequential combination of two electro-dialytic steps for gasification ashes, which was due to a higher influence of iron and/or aluminium in phosphorus solubility for the latter. A product with lower level of metallic impurities and comparable to wet process phosphoric acid was eventually obtained from gasification ashes. Thus, gasification becomes an interesting alternative to incineration also in terms of phosphorus separation.

INTRODUCTION

Increasing global food demand requires greater use of phosphorus (P) from phosphate rock (PR), a mineral which is unevenly distributed worldwide (USGS 2015) and whose geopolitical concerns increases the risk of supply disruption (Cordell & White 2014). Since P is non-renewable on a human time scale (van Dijk et al. 2016), there is a need for recycling technologies. In this context, P recovery from secondary resources like sewage sludge ashes (SSAs) becomes an interesting alternative. Energy recovery processes, like incineration, have been adopted for some of the sewage sludge in developed economies like Europe, Japan or the United States (Samolada & Zabaniotou 2014). However, only a minor part of the resulting SSA are used in the production of fertilizers, due to the presence of heavy metals (HMs) (Ottosen et al. 2013; Ebberts et al. 2015; Parés Viader et al., 2015) and the high content of Al and Fe, which makes it unsuitable for traditional processing methods of PR (Scholz et al. 2014). Thus, around 300,000 Mg of mono-incineration SSA are produced per year in Germany, the biggest producer in the European Union (EU), most of which is currently landfilled or used in construction materials (Krüger et al. 2014, 2015). In this country, as well as in other major SSA producers like Netherlands and Switzerland, there have been recently

several agreements in order to setup pilot plants in the coming years, so as to investigate the recovery of P from incineration SSA in an industrial usable form, like H_3PO_4 solutions.

Gasification of sewage sludge is an interesting alternative to incineration because of a high energy efficiency, less extensive gas cleaning to avoid air pollution and a more flexible use of the syngas produced, which can be employed in several processes like combined heat and power or chemicals production (Ahrenfeldt et al. 2013; Samolada & Zabaniotou 2014). So far, gasification of sewage sludge has not been as extended as incineration, due to the complexity of the technology and its investment and operational costs (Samolada & Zabaniotou 2014); for instance, there are only two fluidised bed gasification plants in Germany with a combined production of less than 6,000 tonnes of SSA per year (Krüger & Adam 2015). Moreover, the direct application of gasification biochar/SSA as fertilizers can also be limited by the heavy metal (HM) content, as well as due to the low plant availability of P.

Previous researches focused on the characterisation of SSA from incineration (Franz 2008; Donatello et al. 2010; L. M. Ottosen et al. 2013) or gasification (Hernandez et al. 2011; Martinez et al. 2014; Parés Viader et al. 2015), including element composition and acid extraction of P and other elements. Electrodialytic (ED) methods have also been investigated to recover P from incineration and low-temperature (LT) gasification SSA with high content in Fe and Al, and separate it from impurities like HMs (Parés Viader et al., 2016). ED setups comprise several compartments delimited by ion exchange membranes; by applying an electrical current, the different elements are released from the bulk ash, and positively charged metallic species are separated from the P anions in the different compartments through electromigration. The setup used differed for each ash: up to 96% of P extraction was achieved for incineration SSA with a 2-compartment (2C) ED setup (Ebbers et al. 2015), whereas the recovery was around 70% for LT gasification SSA (Parés Viader et al., 2016) using a sequential ED process (Fig.1a). However, the sewage sludge originally used in each thermal treatment was different, and so was the composition of the resulting ashes; in the case of P, its content was considerably higher for incineration (12.3%) than for the LT gasification SSA (3.0%). The present study compares the chemical composition, acid and alkaline leachability, as well as the ED P-recovery from SSA produced either by incineration or LT gasification of sewage sludge from the same wastewater treatment plant (WWTP).

METHODS

Experimental SSA

Two different SSA were produced for this research using the same feedstock: sewage sludge collected at the WWTP in the municipality of Bjergmarken, Denmark, where P was captured, approximately, 70% biologically and 30% chemically with Fe chloride sulphate. Al chloride was also used to flocculate and precipitate filamentous bacteria in the sedimentation tank, and its dosing varied during the days that the sewage sludge samples were collected.

Incineration SSA: collected from the mono-incineration plant in Avedøre Wastewater Service, Denmark in a fluidized bed combustor at around 840° C after the sewage sludge was mechanically dewatered.

Gasification SSA: collected from the bottom of the char reactor of a 100 kW experimental LT Circulating Fluid Bed gasifier at the Department of Chemical and Biochemical Engineering,

Roskilde campus of the Technical University of Denmark after the sewage sludge was dried. It was the same gasification unit used in previous researches (Hansen et al. 2015; Parés Viader et al. 2015, 2016).

Analytical methods and sampling

One batch of around 300 grams was sampled from the total mass collected, dried at 105°C overnight, cooled in the fume hood, homogenised with a steel spatula and immediately stored in plastic bags and under dry conditions. Gasification SSAs were loosed with a mortar to facilitate ED experiments.

The concentration of elements was investigated for the in fifteen samples for each untreated ash, and in triplicates after each ED experiments. The targeted elements were: Al, As, Ca, Cd, Cu, Cr, Fe, Mg, Ni, P, Pb, S and Zn. Their content was measured by Varian 720-ES inductively coupled plasma optical emission spectrometry (ICP-OES) after pre-treatment by Danish Standard 259:2003 (DS259): 1 g ash and 20mL 7.3 M HNO₃ were heated at 200 kPa (120°C) for 30 min. The liquid was thereafter separated by vacuum filtration through a 0.45 µm filter and diluted to 100 mL with deionised (DI) water.

The mineralogy of both SSA was examined using X-ray powder diffraction (XRPD) with a PANalytical X'Pert PRO, and the results were analysed using X'Pert HighScore Plus with ICDD PDF 2 database.

pH release

In order to assess the solubility of the target elements under acid or alkaline solutions, 2.5 g of ash was shaken at 150 rpm for 1 week with 25 mL of HNO₃ or NaOH in duplicates at 1, 0.7, 0.5, 0.3 and 0.1 M respectively. The same procedure was repeated for de-ionised (DI) water. The pH of each leachate was measured by a PHM220 Lab pH Meter. Content of the targeted elements in the leachate was measured by the Varian 720-ES ICP-OES after filtration through a 0.45 µm syringe filter, and compared to the total amount in the untreated ashes as described in the previous section.

ED experimental setup

An illustration of two of the ED methods used is shown in Fig. 1. The sequential process (Fig. 1a) was similar to a previous research (Parés Viader et al., 2016). The first step cell consisted of two compartments made of cylindrical Plexiglas® with an internal diameter of 8 cm separated by a cation exchange membrane (CEM). The anode compartment was 10 cm long and contained 35 g ash and 350 ml DI water. The second step cell consisted also of two compartments of identical characteristics to the first step separated by an anion exchange membrane (AEM); in this case, the cathode compartment contained 20-25 g of the bulk ash resulting from the first step and 300 ml of NaOH 0.15 M. A plastic strip attached to a glass-stick connected to an overhead stirrer (IKA RW11) was used to stir the ash suspensions during the experiments. In the cathode compartment of the first step, 500 mL electrolyte solution (0.01 M NaNO₃, pH < 2 adjusted with HNO₃) was circulated by a Plastomec pump model P05. In the anode compartment of the second step, the anolyte resulting from the first step was circulated using the same pump model after vacuum filtration through a 0.45 µm filter.

The split setup (Fig. 1b) consisted of three compartments made of Plexiglas® with an internal diameter of 8 cm, in which the middle compartment was 10 cm long and contained 35 g ash and 350 ml DI water. One electrode was placed in each compartment, and the cathode was simultaneously connected to two anodes by means of two power supplies. An AEM was placed between the two anode compartments, whereas a CEM was placed between the middle and the

cathode compartment. In the end anode compartment, 500 mL of 0.01 M H_3PO_4 was circulated, whereas in the cathode compartment 500 mL of electrolyte solution (0.01 M NaNO_3 , pH < 2 adjusted with HNO_3) was circulated; in both cases using the same model pump as before. With this setup, it was expected to achieve:

- A similar degree of cationic migration as in a 2C setup, as the electrical current at the cathode was the same (50 mA, see next section).
- Less solubilisation of metals with lower acid-leachability than Ca (like Fe or Al), since the ash suspension was subjected to half the current (25 mA) than in the 2C setup, and thus a lower proton load generate at the anode by electrolysis.

In order to accelerate the pH decrease at the beginning of the split ED experiments, 50 mA were applied only between the anode in the middle compartment and the cathode for the first 6 (Incineration SSA) and 48 hours (Gasification SSA).

The electrodes were made of platinum coated titanium wire (diameter 3 mm) obtained from Permascand®. An Agilent E3612A DC power supply was used to maintain a constant DC current. The CEM and AEM used were from Ionics (model CR67 and AR204SZRA respectively).

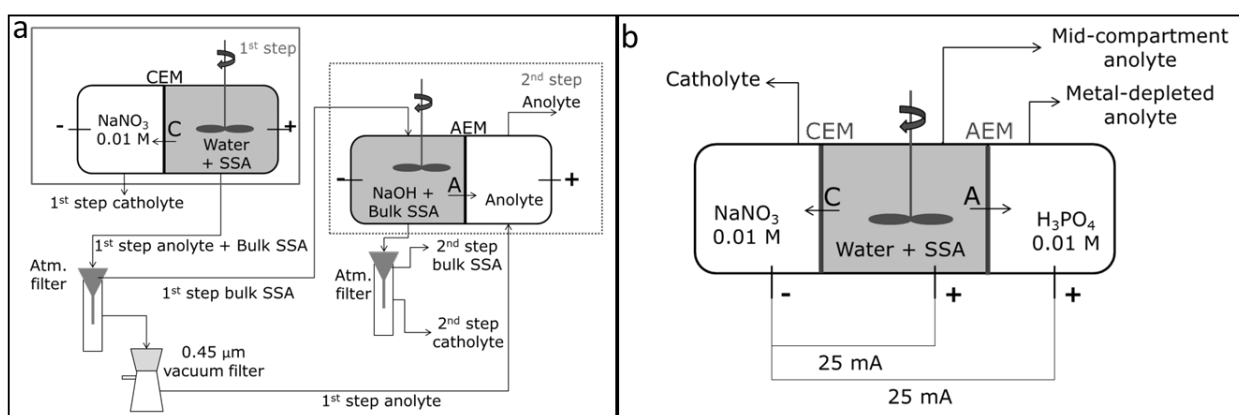

Fig. 1. Schematic view of the sequential ED process (a) and the split ED setup (b). C: cations, A: anions.

ED experiments

Eleven sets of ED experiments were made (Table 1): five for Incineration (I1-I5) and six for Gasification SSA (G1-G6). For the former, all experiments consisted of a single step, whereas a sequential process was used in four experiments for the latter. The intensity was 50 mA, chosen following the findings from previous researches using ED on incinerated and gasified SSA (Parés Viader et al., 2016). Voltage between the electrodes was monitored during the whole experiment. The pH in both compartments and the conductivity of the ash suspension were measured twice a day during the ED experiments. The pH of the catholyte of the first step was adjusted to <2 with HNO_3 5M, to avoid precipitations due to the production of OH^- by the electrode reaction at the inert cathode.

Table 1. Names and conditions of the ED experiments.

| Experiment name | SSA used | Experimental time (1 st /2 nd step) [Days] | ED setup |
|-----------------|--------------|--|---|
| I1 | Incineration | 5 | 2C |
| I2 | | 6 | |
| I3 | | 6 | Split |
| I4 | | 7 | 2C |
| I5 | | 8 | |
| G1 | Gasification | 4/5 | Sequential 2C (both steps) |
| G2 | | 5/5 | |
| G3 | | 6/5 | |
| G4 | | 6/5 | Sequential split (1 st step) and 2C (2 nd step) |
| G5 | | 7 | 2C |
| G6 | | 9 | |

At the end of each step, the ash suspension was filtered at atmospheric pressure, and for the first step it was flushed with 200 mL of DI water in order to displace the elements in solution retained in the humidified ash. The resulting liquid volume was measured, and the ash was dried during 48 hours at 50 °C. The dried ash was loosened by hand in a mortar and stored in plastic bags and under dry conditions. The electrodes were rinsed in 5 M HNO₃, the membranes in 1 M HNO₃. Catholyte and anolyte samples were taken in 20 mL vials before applying the electrical current and after 5 minutes of electrolyte circulation; at the end of all experiments, the catholyte and anolyte volumes were measured, and samples for each were also taken in 20 mL vials. The concentrations of the elements were measured in all of the liquids by ICP-OES after filtration through a 0.45 µm syringe filter.

Experimental ED parameters

The ED experiments were evaluated in terms of rates of P recovery and the impurity level of the obtained product. The amounts of P found in the anolytes of the 1st and 2nd steps were considered as recovered, since they were expected to be solutions rich in this element and depleted of impurities like metallic cations. The overall % of P recovered was calculated as:

$$\%P \text{ recovery} = \frac{P \text{ in anolytes}}{\text{Total P at the end of the experiment}}$$

And the amount of P in the anolytes was calculated as:

$$V_{1^{st} \text{ step}} \cdot C_{P-1^{st} \text{ step}} + V_{2^{nd} \text{ step}} \cdot C_{P-2^{nd} \text{ step}} \cdot \frac{m_{\text{ash}-1^{st} \text{ step}}}{m_{\text{ash}-2^{nd} \text{ step}}}$$

Where $V_{1^{st} \text{ step}}$ and $V_{2^{nd} \text{ step}}$ were the volumes of the anolytes, $C_{P-1^{st} \text{ step}}$ and $C_{P-2^{nd} \text{ step}}$ the concentration of P in the anolytes at the end of each ED step, whereas $m_{\text{ash}-1^{st} \text{ step}}$ were the mass of dry ash after the 1st step and $m_{\text{ash}-2^{nd} \text{ step}}$ the mass used in the 2nd step. The inclusion of the ratio between $m_{\text{ash}-1^{st} \text{ step}}$ and $m_{\text{ash}-2^{nd} \text{ step}}$ multiplying the second term was used to extrapolate the result of the 2nd ED step to all the bulk dry ash mass after the 1st step.

In order to assess the amount of impurities in the recovered P, it was compared to WPA, the product of leaching PR with sulfuric acid (Gilmour 2014) which is applied to over 70% of mined PR

(Scholz et al. 2014). A common parameter to evaluate the level of impurities of WPA, and its suitability in the fertilizer industry is the minor element ratios (MER), defined as:

$$MER = \frac{Fe_2O_3 + Al_2O_3 + MgO}{P_2O_5}$$

RESULTS AND DISCUSSIONS

SSA characterisation

Element concentrations of the two untreated ashes are shown in Table 2. Most elements presented a high standard deviation, as it can be expected in inherent inhomogeneous materials. Cd concentrations in the liquids from the DS259 pre-treatment of Gasification ash were found to be below the limit of detection (LOD, 0.02 ppm) in 12 out of 15 samples, and therefore the concentration is given as a range, and no mass balance or pH release result is shown for this element.

Table 2. Concentration (average±standard deviation) of elements in the two studied SSA. The results are compared with the element concentrations found in literature for incineration SSA and gasification SSA.

| Element | Incineration SSA | Gasification SSA | German incineration SSA, average values (Krüger et al. 2014) | Gasification SSA values in literature (Gil-Lalaguna et al. 2015; Hernandez et al. 2011) | Units |
|-----------|------------------|------------------|--|---|-------|
| Al | 28.3±4.4 | 51.2±1.1 | 52 | 23-61 | g/kg |
| Ca | 132±47 | 135±27 | 138 | 84-148 | g/kg |
| Fe | 63.2±13 | 61±1.8 | 99 | 88-123 | g/kg |
| Mg | 11.9±2.2 | 12.9±1.3 | 14 | 25-36 | g/kg |
| P | 88.4±21 | 96.0±15 | 90 | 51-149 | g/kg |
| S | 8.77±2.1 | 5.58±0.5 | 15 | 0.2-41 | g/kg |
| As | 11.4±1.4 | 5.82±0.33 | 17.5 | N/A | mg/kg |
| Cd | 4.19±2.8 | <2-3.6 | 3.3 | <LOD | mg/kg |
| Cr | 57.7±4.3 | 89.2±7.4 | 267 | 98-137 | mg/kg |
| Cu | 588±43 | 479±31 | 916 | 1,159-1,367 | mg/kg |
| Ni | 58.1±3.7 | 57.9±9.7 | 105.8 | 122-165 | mg/kg |
| Pb | 208±100 | 137±87 | 151 | 51-90 | mg/kg |
| Zn | 2,120±230 | 1,650±250 | 2,535 | 753-877 | mg/kg |

Average concentrations of Ca, P, Fe and Mg for Incineration compared to Gasification ashes were in the range of ±10%, and therefore a fair comparison of both SSA in terms of P leachability and ED-recovery can be made. Differences in Al are probably attributable to differences in the dosing of aluminium chloride in the WWTP (see section Experimental SSA). S and HMs content were on average slightly higher for Incineration SSA, which is probably because they were produced by mixing of fly ashes and bottom ashes. In contrast, gasification SSA consists only of the bottom ash fraction; the higher concentration for Cr is most likely due to releases from the materials used in the gasifier, although it requires further study.

Incineration SSA concentrations were compared to the average values from a survey of incineration SSA in Germany (Krüger et al. 2014). P concentrations were found to be very similar, considering only values from municipal SSA. Differences in Al and Fe can be due to a higher dosing of Al and Fe salts in German WWTP. As, Cr, Cu, Ni and Zn concentrations were on average higher in German SSA, which is because the survey included a mean value including both municipal and industrial SSA. Concentrations in the Gasification ashes of this study were compared to previous researches on gasification SSA (Hernandez et al. 2011; Gil-Lalaguna et al. 2015). On average, Al, Ca, P, S and Cr content were in the range of literature values, whereas the rest of elements were below it, except for Pb and Zn. The reason for the lower Fe concentration can be again a lower dosing of Fe salts in Bjergmarken WWTP.

The mineralogy study showed two common phases for both SSA: quartz (SiO_2) and calcium phosphates ($\text{Ca}_9\text{Fe}(\text{PO}_4)_7$, $\text{Ca}_9\text{Al}(\text{PO}_4)_7$ and/or $\text{Ca}_7\text{Mg}(\text{PO}_4)_6$). For Incineration SSA, hematite (Fe_2O_3) and anhydrite (CaSO_4) were also identified. These phases were respectively identified in other incineration (Franz, 2008; Donatello et al. 2010; Ottosen et al. 2014; Li et al. 2015) and gasification SSA (Hernandez et al. 2011; Gil-Lalaguna et al. 2015). The presence of Fe_2O_3 in incineration SSA is due to the reaction of iron phosphate with lime, and the consequent formation of more acid-soluble calcium phosphate (Martinez et al. 2014; Li et al. 2015). In contrast, the lack of hematite in Gasification SSA could indicate the presence of FePO_4 , although it was not identified neither in the XRPD analyses of the present work nor in previous studies on gasification SSA (Hernandez et al. 2011; Gil-Lalaguna et al. 2015). One reason could be that it was found in an amorphous phase, since there was a hump in the pattern from 10° to 40° (2θ), but it requires further study.

pH release experiments

The solubilisation of all elements generally increased with lower pH values for both Incineration and Gasification SSA (Fig. 2). P leaching was lower for Gasification than for Incineration SSA on each acid concentration, except for the highest acid load (1 M HNO_3). In fact, P was not completely solubilised in this acidic extraction (88% with pH 0.7) for Incineration ashes; this is in contradiction with the results obtained in previous studies (Ottosen et al. 2013), where most P was extracted at $\text{pH}\sim 1$, and it is most likely due to the inherent inhomogeneity of the ashes. P concentrations were $8.1\cdot 10^{-2}$ M at pH 2.4 for Incineration, and $3.4\cdot 10^{-2}$ M at pH 1.9 for Gasification ashes; Fe(III), Al- and Ca- phosphates solubility at pH 2 are in the range of $10^{-3}\text{-}10^{-4}$ M, $10^{-3}\text{-}10^{-2}$ and >1 M, respectively (Stumm & Morgan 1996; Kuroda & Okido 2012). Thus, P release is influenced simultaneously by these three metals for both SSA at low pH, with a higher influence of Al and Fe in Gasification than in Incineration ashes. At high pH values, P solubilised for both SSA, but to a higher degree for Gasification. This suggests the presence of alkaline-soluble P bindings, like Fe(III)-P and/or Al-P, as previously seen for other LT gasification SSA (Parés Viader et al., 2016). Nevertheless, P-solubility for Gasification SSA at pH 1.9 ($3.4\cdot 10^{-2}$ M) was one order of magnitude higher than in these LT gasification ashes at pH 2.1 ($2.6\cdot 10^{-3}$ M) (Parés Viader et al. 2015), probably because a higher proportion of chemically captured P (50%) in the original sewage sludge of the latter. For Incineration SSA, Fe leaching was lower than in Gasification ashes in all acidic pH values, which can be due to the formation of acid-insoluble iron oxides from Fe-phosphates in the former (see section SSA characterisation).

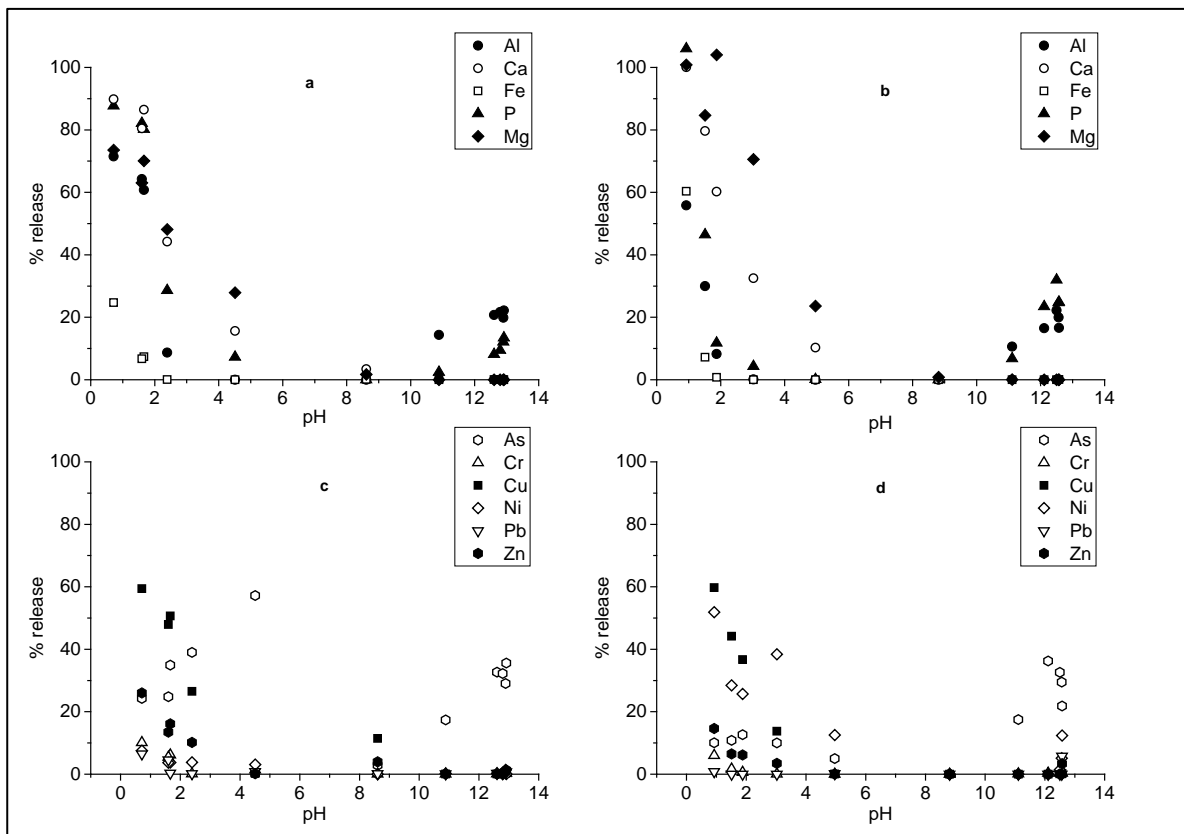

Fig. 2. pH release of the studied elements in Incineration (a,c) and Gasification (b,d) SSA.

The concentrations of most HMs in the acidic leachates of Incineration ashes were higher than the values of Gasification ashes leachates, with As, Pb and Zn being at least a twofold higher, for the same HNO_3 load. On the contrary, Ni leachability in all acid tests was around one order of magnitude higher in Gasification SSA; the results for Incineration SSA at pH 0.7 (7.5%) were also lower than the results from a previous work with similar incineration SSA at around pH 1 (~35%) (Ottosen, et al. 2013). Leachate concentrations under alkaline extractions were higher for As in Incineration and for Ni in Gasification SSA, while the rest of HMs, together with Fe and Al, leached below 5% for both SSA, probably because of the formation of metallic hydroxides.

ED experiments

Mass balances

The element distribution in the different compartments at the end of the experiments was determined, considering that:

- The catholyte, the cathode and the cationic membrane were grouped as the cathode compartment in the 1st step. In the 2nd step, the cathode compartment comprised the cathode and the catholyte.
- The total mobilisation or release of each element, including P, was the sum of the masses found in all electrolyte solutions, membranes and electrodes at the end of the experiments minus the initial concentrations of these elements in these compartments.

- In the split experiment I3, the P in both anolyte liquids (mid-compartment and metal-depleted) was considered as recovered. For split experiment G4, only the P in the metal-depleted anolyte was considered as recovered since its amount was over 50 times higher than the one found in the mid-compartment anolyte. Furthermore, the ratio of metals to P in the anolytes of the split experiments was calculated by the difference between the concentrations at the end and at the beginning of the experiments.
- The amount of each element migrated to the catholyte in the 1st step, and to the anolyte in the 2nd step was defined as the difference in each element amount in the electrolyte solution at the end minus at the start of the step.

Mass balances for each element (except Cd), defined as the division of the amount found at the end of the experiments by the mass initially found in the initial SSA and the liquids placed in the ED cell, were made to control the quality of each step of the experiments. Most elements in each step were found in the range or around 80-120%, except for Pb (52-144%), which is due to its inhomogeneity in both SSA (Table 2). Concentration measurements which were below the LOD used in the ICP-OES analyses (0.02 mg/L), were considered to have this value, except for the initial 1st step catholyte samples, which were considered to be zero. This enabled to calculate the mass balances and the worst-case value for the ratio HM/P in the anolytes, which was the recovered P-product. The overall impact of these approximations was below 1% of the total final element mass found at the end of the ED experiments.

ED cell voltage, ash suspension conductivity and pH

The voltage between electrodes decreased during the 1st step of most ED experiments, in parallel to the increase in electrical conductivity. At the same time, the pH decreased in the SSA suspensions to 2 ± 0.3 for all experiments except for I5 (1.3) and G4 (2.4). The main reason for this was the generation of protons in the anode together with the element release from the ashes. The sole exception was experiment G4, as the voltage in both power supplies increased from 8 to 17 V between 48-96 hours, and decreased afterwards to 10 V. This increase suggests the migration of ions other than protons from the suspension, which entailed a decrease in conductivity, since its pH was stable in the range 2.4-2.8 after 48 hours. In the 2nd step of G1-G4, the voltage increased after approximately 24 hours from ~7V to ~25 V and decreased progressively the following 24 hours to ~7V. This can be caused by a temporary fouling of the membrane, which was not observed in previous experiences (Parés Viader et al. 2015, 2016), and needs to be addressed in future research. In all experiments, the pH increased steadily up to ~12 after 48 hours, and reached ~12.5 at the end of the experiments.

P-recovery in ED experiments

Fig. 3 shows that a higher extraction of P to the anolytes was achieved with longer experimental times using the 2C setup (not considering the split setup) for Incineration SSA, with the exception of the 5-day experiment. Moreover, there was a sharp increase between the 7- and the 8-day tests. Since Ca represented more than 80% of the mobilised metal mass in all experiments, the reason can be a higher amount of P (Fig. 3) and a higher proportion of Ca-P bindings over other Ca-compounds for the ashes in experiments I1 and I5: the molar ratio of mobilised Ca to P (mobilised Ca/P) was around 1.4, close to the one of tricalcium phosphate (1.5), and lower than for I2 (2.2) and I4 (2.0). Thus, there was a lower content of compounds competing with Ca-P dissolution, like CaSO₄ or CaCO₃, in I1 and I5. For Gasification SSA, higher P-extractions were also generally achieved at longer remediation times in the 1st step (not considering the split setup, Fig. 3).

Nevertheless, the amount of P extracted was lower for Gasification ashes after 5, 6, and 7 days in the 1st step than after the treatment of Incineration ashes with the same times (Fig. 3). The reason can be the higher influence of Fe(III) and Al in P solubility in the Gasification SSA (see section pH release experiments). In fact, most P in the bulk SSA after the 1st step would be bound to Fe(III) and/or Al, as molar Ca/P ranged from 0.3 (G5 and G6) to 0.6 (G1), well below the value of tricalcium phosphate (1.5). Higher remediation time in the ED experiment increased the amount of P migrated to the cathode compartment (Fig. 3) and a higher MER in the anolyte (Table 3). This was probably due to a higher solubilisation of Fe (III), which enabled the formation of positively charged complexes with phosphate ions, preventing their effective separation (Parés Viader et al. 2015). Therefore, in order to increase P recovery, a sequential ED process needs to be used (Fig. 3a), so that Fe(III)-P bindings are solubilised through an increase of pH, and Fe(III) is precipitated as hydroxides. A second step was applied to the ashes of the three shortest remediation times (G1-G3), increasing the extraction to the levels achieved with Incineration ashes (Fig. 3). For G1, the amount of P recovered was higher than for G5 with the same total duration of the ED treatment (9 days). The molar Ca/P in the bulk Gasification SSA after the 2nd step was around 1.2 for the three experiments, which could be translated into an 80% of P bound to Ca. In consequence, most existing Fe(III)-P and Al-P bindings were effectively dissolved. The achieved P-recoveries were up to 80% (I5) from Incineration ash and up to 69% (G2) for Gasification ashes, which are similar to previous ED recoveries achieved on incineration and LT gasification SSA (Ebbers et al. 2015; Parés Viader et al., 2016). All recoveries can be seen in Table 3.

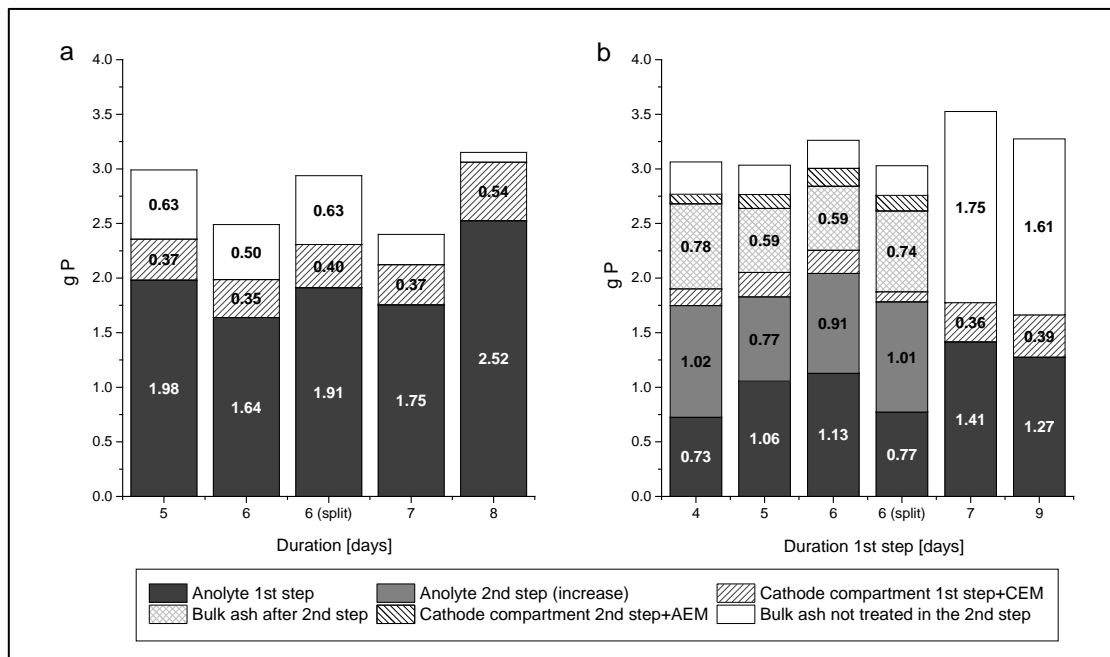

Fig. 3. P distribution at the end of the ED experiments for Incineration (a) and Gasification (b) SSA.

Characteristics of the recovered P-liquids

The resulting anolytes were acidic (pH<2), and the achieved P-concentrations were higher than in previous researches, where the concentration was below 2 g P per litre (Parés Viader et al., 2016), but several orders of magnitude below the concentration found in WPA (Table 3), which needs to be addressed together with the high proportion of S in the solution.

The ratios of Al, Fe and Mg to P in the resulting P-liquids were generally higher for Incineration than for Gasification ashes (G1-G4, Table 3). This is due to the lower solubility of Al in Gasification than Incineration SSA at pH~2 (Fig. 2) and the use of the 2nd step, since Fe and Mg were not soluble at pH~12 (see Fig. 2 and section pH release experiments). An adaptation of the sequential ED process to treat Incineration SSA could therefore be beneficial, but it requires further study. However, MER values achieved using 2C setups were always above 0.085, the technical limit of WPA to be used in Diammonium Phosphate (DAP), the world's more common mineral fertilizer (Gilmour 2014). This was also observed in previous ED treatment of incineration SSA (Ebbers et al. 2015). In order to reduce this ratio, the split setup (Fig. 1b) was used for both ashes (I3 and G4); for Gasification, as a 1st step. The amount of P extracted with this setup was in line with the other results (Fig. 3), and at the same time a lower MER (and below 0.085, Table 3) was achieved.

HM/P ratios in the analytes were below the initial SSA ones (calculated from the average values in Table 2) and, for some elements, in the range or below the values found in WPA. Remarkably, some P-liquids from Gasification ash had only Pb/P values above these ranges. Overall, the ratio of As, Cr, Cu, Ni, Pb and Zn to P were higher in Incineration than in Gasification ashes. This is probably due to the lower solubility of some of these metals in acid medium in the latter, as well as the use of the 2nd ED step (experiments G1-G4), where most HMs became insoluble due to the alkaline conditions (see section pH release experiments). Additionally, the higher concentration of S in the anolyte solutions of Incineration SSA (Table 3) could enable the formation of neutrally charged sulphate complexes with Cu, Ni, Pb and Zn, like NiSO₄ (aq), although it requires further study. The use of a split setup allowed generally lower of Cr, Cu and Zn to P; especially for Gasification ash, because the final pH in the ash compartment (2.4) was higher than the other 1st step experiments with the 2C setup (~2).

Table 3. P-recovery (%) and parameters of the analyte solutions at the end of each experiment. The results are compared with the values found in WPA, and the metals exceeding its ranges are shown in bold, together with MER values higher than 0.085. ¹calculated as an estimation of mixing the two analyte liquids, ²from the metal-depleted analyte, *below LOD in ICP-OES.

| Parameter | Experiment | | | | | | | | | | | WPA (Gilmour 2014) | Units |
|--------------|--------------|--------------|-----------------|--------------|-------------|-------------|-------------|-------------|-----------------|-------------|-------------|-----------------------|---------|
| | I1 | I2 | I3 ¹ | I4 | I5 | G1 | G2 | G3 | G4 ² | G5 | G6 | | |
| % P-recovery | 66 | 66 | 68 | 73 | 80 | 63 | 69 | 68 | 64 | 40 | 39 | - | - |
| Content of P | 4.6 | 3.7 | 2.3 | 4.2 | 6.2 | 4.1 | 5.2 | 5.5 | 4.4 | 3.5 | 3.2 | ~340-450 | g P/L |
| Content of S | 0.51 | 0.50 | 0.30 | 0.66 | 0.80 | 0.18 | 0.27 | 0.21 | 0.19 | 0.06 | 0.06 | 0.3-0.7 | g S/L |
| Al/P | 0.16 | 0.17 | 0.06 | 0.14 | 0.12 | 0.10 | 0.10 | 0.09 | 0.06 | 0.13 | 0.21 | <0.03 | |
| Fe/P | 0.07 | 0.08 | 0.04 | 0.11 | 0.10 | 0.01 | 0.03 | 0.03 | <0.01 | 0.10 | 0.22 | <0.04 | kg/kg P |
| Mg/P | 0.03 | 0.04 | 0.02 | 0.03 | 0.01 | 0.01 | 0.02 | 0.02 | <0.01 | 0.04 | 0.04 | 0.01-0.03 | |
| MER | 0.20 | 0.23 | 0.08 | 0.20 | 0.18 | 0.10 | 0.12 | 0.11 | 0.05 | 0.20 | 0.34 | - | - |
| As/P | 149 | 122 | 138 | 132 | 91 | 64 | 62 | 49 | 34 | 38 | 57 | 20-70 | |
| Cd/P | 8 | 12 | 8 | 11 | 7 | 7 | <4* | <4* | <5* | <6* | <6* | 120-500 | |
| Cr/P | 105 | 116 | 64 | 150 | 105 | 25 | 22 | 22 | 7 | 36 | 64 | 100-3,000 | |
| Cu/P | 1,190 | 1,750 | 845 | 1,220 | 684 | 89 | 222 | 247 | 20 | 648 | 748 | 10-400 | mg/kg P |
| Ni/P | 66 | 74 | 119 | 69 | 41 | 62 | 23 | 6 | 61 | 159 | 181 | 100-700 | |
| Pb/P | 25 | 25 | 23 | 303 | 214 | <5* | <4* | 6 | 14 | <6* | 8 | <4 | |
| Zn/P | 917 | 1,200 | 628 | 977 | 963 | 203 | 279 | 249 | 35 | 472 | 782 | 100-10,000 | |

CONCLUSIONS

Two different ED methods were used in order to achieve comparable extraction of P from ashes of incineration and gasification of the same sewage sludge. For the former, a 2C setup allowed a recovery of up to 80%; for the latter a sequential ED process was required to recover up to 69% of P, because of a higher presence of Fe(III)-P bindings and in order to prevent the formation of Fe-phosphate complexes. In general, higher remediation times allowed higher amount of recovered P, although this was influenced by the inhomogeneity of the ashes. Using these techniques, the resulting H₃PO₄ solutions from gasification ash had overall lower ratios of Al, Fe, Mg and HMs to P than from incineration ash. This was possible due to lower solubilisation of most HMs in the gasification SSA, as well as the use of the additional step in the sequential ED process which involved P-extraction at high pH, where most metals are insoluble.

The content of Al, Fe, Mg and some of the HMs was high in this liquids compared to WPA, which could complicate their usage in the production of commercial fertilizers like DAP. A considerable reduction of these impurities was obtained by using a new ED setup (split), making it an interesting alternative to separate P from SSA; especially because Fe concentration in commonly produced SSA tend to be higher than in the ashes of the present study.

REFERENCES

- Ahrenfeldt, J., Thomsen, T., Henriksen, U. B., & Clausen, L. R. 2013. Biomass gasification cogeneration – A review of state of the art technology and near future perspectives. *Applied Thermal Engineering*, **50**(2), 1407-1417.
- Cordell, D., & White, S. 2014. *Life's Bottleneck: Sustaining the World's Phosphorus for a Food Secure Future*. In A. Gadgil & D. M. Liverman, Annual Review of Environment and Resources, Vol 39, Palo Alto.
- Donatello, S., Tong, D., & Cheeseman, C. R. 2010. Production of technical grade phosphoric acid from incinerator sewage sludge ash (ISSA). *Waste Management*, **30**(8-9), 1634-1642.
- Ebbers, B., Ottosen, L. M., & Jensen, P. E. 2015. Comparison of two different electro-dialytic cells for separation of phosphorus and heavy metals from sewage sludge ash. *Chemosphere*, **125**, 122-129.
- Franz, M. 2008. Phosphate fertilizer from sewage sludge ash (SSA). *Waste Management*, **28**(10), 1809-1818.
- Gil-Lalaguna, N., Sanchez, J. L., Murillo, M. B., & Gea, G. 2015. Use of sewage sludge combustion ash and gasification ash for high-temperature desulphurization of different gas streams. *Fuel*, **141**, 99-108.
- Gilmour, R. 2014, Phosphoric Acid Purification, Uses, Technology, and Economics. CRC Press, Taylor& Francis Group, Boca Raton, US.
- Hansen, V., Müller-Stöver, D., Ahrenfeldt, J., Holm, J. K., Henriksen, U. B., & Hauggaard-Nielsen, H. 2015. Gasification biochar as a valuable by-product for carbon sequestration and soil amendment. *Biomass & Bioenergy*, **72**, 300-308.
- Hernandez, A. B., Ferrasse, J. H., Chaurand, P., Saveyn, H., Borschneck, D., & Roche, N. 2011. Mineralogy and leachability of gasified sewage sludge solid residues. *Journal of Hazardous Materials*, **191**(1-3), 219-227.
- Krüger, O., & Adam, C. 2015. Recovery potential of German sewage sludge ash. *Waste Management*, **45**, 400-406.
- Krüger, O., Grabner, A., & Adam, C. 2014. Complete Survey of German Sewage Sludge Ash. *Environmental Science & Technology*, **48**(20), 11811-11818.

- Kuroda, K., & Okido, M. 2012. Hydroxyapatite Coating of Titanium Implants Using Hydroprocessing and Evaluation of Their Osteoconductivity, *Bioinorganic Chemistry and Applications*, **Volume 2012**, pp. 730693.
- Li, R. D., Zhang, Z. H., Li, Y. L., Teng, W. C., Wang, W. Y., & Yang, T. H. 2015. Transformation of apatite phosphorus and non-apatite inorganic phosphorus during incineration of sewage sludge. *Chemosphere*, **141**, 57-61.
- Martinez, M. A., Gea, G., Arauzo, J., Kersten, S. R. A., & Kootstra, A. M. J. 2014. Phosphorus recovery from sewage sludge char ash. *Biomass & Bioenergy*, **65**, 42-50.
- Ottosen, L. M., Kirkelund, G. M., & Jensen, P. E. 2013. Extracting phosphorous from incinerated sewage sludge ash rich in iron or aluminum. *Chemosphere*, **91**(7), 963-969.
- Ottosen, L. M., Jensen, P. E., & Kirkelund, G. M. 2014. Electrodialytic Separation of Phosphorus and Heavy Metals from Two Types of Sewage Sludge Ash. *Separation Science and Technology*, **49**(12), 1910-1920.
- Parés Viader, R., Jensen, P. E., Ottosen, L. M., Ahrenfeldt, J., & Hauggaard-Nielsen, H. (2015). Electrodialytic extraction of phosphorus from ash of low-temperature gasification of sewage sludge. *Electrochimica Acta*, **181**, 100-108.
- Parés Viader, R., Jensen, P. E., Ottosen, L. M., Ahrenfeldt, J., & Hauggaard-Nielsen, H. (2016). Sequential electrodialytic recovery of phosphorus from low-temperature gasification ashes of chemically precipitated sewage sludge, *Waste Management*.
- Samolada, M. C., & Zabaniotou, A. A. 2014. Comparative assessment of municipal sewage sludge incineration, gasification and pyrolysis for a sustainable sludge-to-energy management in Greece. *Waste Management*, **34**(2), 411-420.
- Determination of metals in water, sludge and sediments - General guidelines for determination by atomic absorption spectrophotometry in flame*. Danish Standard 259:2003, 2003.
- Stumm, W., & Morgan, J. J. 1996. Aquatic chemistry: Chemical equilibria and rates in natural waters. Wiley.
- Scholz, R. W., Roy, A. H., Brand, F. S., Hellums, D. T., Ulrich, A. E. 2014, Sustainable phosphorus management : a global transdisciplinary roadmap. Springer, Heildeberg.
- Mineral Commodity Summaries 2015*, USGS, Virginia, USA.
- van Dijk, K. C., Lesschen, J. P., & Oenema, O. 2016. Phosphorus flows and balances of the European Union Member States. *Science of the Total Environment*, **542**, 1078-1093.

Paper IV

“Electrodialytic remediation of municipal solid waste incineration residues using different membranes,” *Chemosphere*, vol. 169, pp 62-68, 2017



Electrodialytic remediation of municipal solid waste incineration residues using different membranes



Raimon Parés Viader*, Pernille Erland Jensen, Lisbeth M. Ottosen

Department of Civil Engineering, Technical University of Denmark, Building 118, 2800 Kongens Lyngby, Denmark

HIGHLIGHTS

- Municipal Solid Waste Incineration (MSWI) residues are common in western countries.
- Four membrane brands are compared to treat MSWI residues using electro dialysis.
- Element leaching is generally reduced regardless the membrane used.
- Leaching of some elements in the treated residues varies depending on the membrane.

ARTICLE INFO

Article history:

Received 18 August 2016

Received in revised form

7 November 2016

Accepted 9 November 2016

Handling Editor: Shane Snyder

Keywords:

MSWI

APC residues

Fly ashes

Heavy metals

Electrodialysis

ABSTRACT

In the present work, three different commercial membrane brands were used in an identical electro-dialytic cell setup and operating conditions, in order to reduce the leaching of metals and salt anions of two types of municipal solid waste incineration residues: air pollution control residues of a semi-dry flue-gas cleaning system and fly ashes from a plant with wet flue-gas cleaning system. The results showed a general reduction of the leaching in both residues after ED remediation. For the following elements, the leaching was found to be different after ED treatment depending on the membrane used, with statistical significance:

- Air pollution control residues of the semi-dry flue-gas cleaning system: Cr, Cu, Ni, Pb, Zn;
- Fly ashes from a plant with wet flue-gas cleaning system: Al, Ba, Cu, Ni, Zn, Cl, SO₄.

Final leaching values for some elements and membranes, but not the majority, were below than those of certified coal fly ash (e.g. Al or Cr), a material which is commonly used in construction materials; at the same time, some of these values were reduced to below the Danish law thresholds on the use of contaminated soil in constructions. These results show the potential of ED as a technology to upgrade municipal solid waste incineration residues.

© 2016 Elsevier Ltd. All rights reserved.

1. Introduction

Worldwide municipal solid waste generation is expected to double by 2025 (Hoornweg and Bhada-Tata, 2012). Improving solid waste management is therefore an urgent priority. In many developed countries, a common practice is the incineration of solid waste, as it reduces the volume of waste by up to 90% (Hoornweg and Bhada-Tata, 2012) and allows energy recovery. Worldwide, approximately 120 million tonnes of waste are incinerated every year (Hoornweg and Bhada-Tata, 2012). This practice generates fly ashes (FA) and air pollution control (APC) residues, originating from

the treatment of the flue gas coming out of the combustion chamber, and constituting 1–5% of the original waste by mass (Sabbas et al., 2003). FA and APC residues are hazardous and contain several pollutants; among them, salts and heavy metals (Quina et al., 2008a).

Both residues can have different potential applications as substitution of other raw materials in production of construction materials (Ferreira et al., 2003). However, such use is not allowed in some countries like Denmark, where (as in many other western countries) FA and APC residues are normally deposited after treatment (Quina et al., 2008a). At the same time, huge amounts of virgin resources are used in the construction sector. An upgrade to a higher environmental standard (like a reduced metal and salts leaching), could make them suitable for substitution of raw materials in e.g. concrete production.

* Corresponding author.

E-mail address: rapv@byg.dtu.dk (R. Parés Viader).

Electrodialysis (ED) has been proven a promising technology for this purpose (Kirkelund et al., 2010; Jensen et al., 2010). ED is based on application of an electrical current to a solution or a solid suspension containing ions, forcing cations to move towards the cathode and anions towards the anode. Ion exchange membranes (IEMs), which are able to let chemical species pass depending on their charge, are strategically placed to separate cations and anions from an ion-rich compartment into different compartments. The ED setup used in this work can be seen in Fig. 1.

Previous research has focused on optimising different processing parameters for ED treatment of different materials such as contaminated soils and harbour sediments, municipal solid waste incineration (MSWI) FA/APC residues or sewage sludge ashes; important parameters being the liquid-to-solid ratio (L/S), duration of treatment, current intensity, pH as well as the number of cell compartments or the use of chemicals like H_2SO_4 (Jensen et al., 2007a; Nystroem et al., 2005; Kirkelund et al., 2013; Guedes et al., 2016). The performance of different commercial IEMs has been compared in several ED processes like the denitrification of an aqueous solution (Ulises et al., 2011), the removal of organic salts from a fermentation broth (Gong et al., 2006), as well as the production of acid from waste pickle solutions (Akgemci et al., 2005). Their results show that the transport of the same ion through the different IEMs can vary substantially among the different brands: up to a threefold for Na^+ and NO_3^- , up to a 1.3-fold for organic salts, and up to a fourfold for Cl^- . Two different ion exchange membrane (IEM) brands have been used in different studies of ED upgrading of MSWI APC residues and FA: Ionics (Kirkelund et al., 2013, 2015; Pedersen et al., 2003) and Neosepta (Kirkelund et al., 2010; Jensen et al., 2010, 2015). The influence of the IEM brand used for ED treatment of MSWI residues has, however, never been investigated.

To better understand the influence of the IEM type on upgrading of APC residues and other particular materials by ED, the present work assesses the performance of four IEM trademarks on the ED treatment of MSWI residues. All IEMs were tested for treatment of two common and different waste materials (MSWI FA and APC residues) in order to evaluate if the IEMs differently affect the MSWI residue characteristics after the ED treatment. The overall aim of the investigation was to compare the leachability changes of these residues, induced by the ED treatment, among the four different IEM brands.

2. Materials and methods

2.1. MSWI residues

Two different Danish MSWI residues were studied:

- I APC residues collected from a semi-dry (SD) flue-gas cleaning system from the MSWI plant REFA I/S. REFA I/S incinerates approximately 120,000 tonnes of household and industrial waste annually. SD were collected on 28th of June 2011 from line 3 after APC additives (slaked lime and activated carbon).
- II FA collected from the electrostatic precipitator in a wet flue-gas cleaning system from the MSWI plant Vestforbrænding I/S, which is the largest plant in Denmark, incinerating approximately 520,000 tonnes of household and industrial waste annually. FA was collected in week 50 in 2011 from the ash silo 5 prior to mixing with the wet scrubber sludge.

After sampling, both residues were dried at 40 °C. They were subsequently dry sieved through a 1 mm sieve, as performed in previous pilot experiments (Kirkelund et al., 2010; Jensen et al., 2010, 2015), to prevent clogging in the flow spacers when scaling

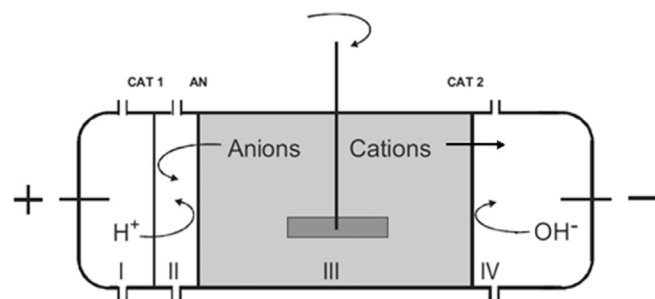

Fig. 1. Schematic view of a cell used for the ED treatment of both APC residues. AN: anion-exchange membrane; CAT1/CAT2: cation-exchange membranes.

up. The removed fraction represented a 1% of the total initial mass (Jensen et al., 2015).

2.2. Analytical methods

Mineralogy, the metal and water soluble salt concentrations and leaching were investigated for both treated and raw MSWI residues after drying them at 105 °C. Water solubility was measured only for the untreated residues. The targeted metals were: Al, As, Ba, Ca, Cd, Cu, Cr (total Cr and Cr (VI)), Mn, Mo, Na, Ni, Pb, Zn, V, Zn; whereas the target anions were: Cl^- , SO_4^{2-} .

The mineralogy of each residue sample was examined using X-ray powder diffraction (XRPD) with a PANalytical X'Pert PRO. Water solubility was calculated by measuring the weight loss after washing the untreated residues: 100 g of each residue was shaken with 500 mL of distilled water for 5 min, and thereafter the supernatant was separated and filtered at atmospheric pressure. This procedure was repeated two more times for the same residue before all the suspension was filtered, and dried overnight at 105 °C. The metal content was measured by ICP-OES (Varian 720-ES ICP-OES) in triplicates after pre-treatment by Danish Standard DS259 (Danish Standard, 2003): 1 g of each residue and 20 mL 7.3 M HNO_3 were heated at 200 kPa (120 °C) for 30 min. The liquid was thereafter separated by vacuum filtration through a 45 μm filter and diluted to 100 mL by de-ionised (DI) water.

The water soluble content of SO_4^{2-} and Cl^- was determined on IC (DIONEX DX-120 IC) in triplicates according to DS/EN ISO 10304-2 (Danish Standard, 2009) after water extraction. This was performed as follows: 2.5 g of each residue and 25 mL distilled water were mixed, shaken for 16 h on a horizontal shaker operating at 150 rpm, and the extractants were vacuum filtered through 45 μm filters.

Leaching experiments were made according to DS/EN 12457-1 (Danish Standard, 2002) in triplicates. The L/S was 2, mixing 40 g of each residue with 80 mL DI water. The resulting suspension was shaken at 150 rpm for 24 h before vacuum filtration through a 45 μm filter and the filtrate was divided into two subsamples after measuring the pH by a Radiometer Analytical pH electrode. One subsample was used to measure sulphate (SO_4^{2-}) and chloride (Cl^-) concentrations on ionic chromatograph (IC). The other was diluted at a ratio of 1.25 with concentrated HNO_3 , and heated at 200 kPa (120 °C) for 30 min, before the metal content analysis on ICP-OES (Varian 720-ES ICP-OES).

2.3. Experimental set-up

The Electrolytic (ED) cell was similar to the ones used in previous experiments (Pedersen et al., 2003; Ferreira et al., 2005). It consisted of four (I, II, III, IV) compartments (Fig. 1) made of cylindrical Plexiglas® with an internal diameter of 8 cm. Compartment III was 10 cm long and contained in each experiment 35 g ash and

350 mL of DI water. An electrolyte solution (0.01 M NaNO₃, pH < 2 adjusted with HNO₃) was circulated in each of the electrolyte compartments (I, II and IV) using Totton Pumps NDP 10/2. The electrolyte solution was selected based on positive results from previous researches (Pedersen et al., 2003; Ferreira et al., 2005), where no reactions were observed between the electrolyte solution and the transported species (for example, precipitate formation) or the electrodes (for example, gas formation) was observed. This can also allow a more accurate calculation of the mass balances explained in Section 2.6. The total volumes used were 500 mL for I and IV, and 350 mL for II. A plastic strip attached to a glass-stick connected to an overhead stirrer (IKA RW11) was used to stir the ash suspension during remediation. The electrodes were made of platinum coated titanium wire (diameter 3 mm) obtained from Permascand®. An Agilent E3612A DC power supply was used to maintain a constant electric dc current. Details on the IEMs used can be found in Section 2.4.

Compartment II was included because a high concentration of soluble salts containing Cl⁻ was expected (Quina et al., 2008a); otherwise, these anions would enter compartment I, enabling the formation of toxic Cl₂ gas from the electrode reaction at the anode: $2\text{Cl}^- \rightarrow \text{Cl}_2 + 2\text{e}^-$

2.4. Membranes

Four IEM pairs were selected according to several criteria. The first two trademarks have been used previously in experimental work with ED of MSWI residues:

- Ionics (cationic: CR67-HMR, anionic: AR204-SZRA from GE), from GE Water & Process Technologies (United States), used in laboratory scale ED cell investigations to reduce the content (Pedersen et al., 2003, 2005) or the leachability (Kirkelund et al., 2015) of heavy metals in MSWI residues.
- Neosepta (cationic: CMX, anionic: AMX), from ASTOM Corporation (Japan), used in two pilot scale ED stack investigations to reduce the leachability of heavy metals, chloride and sulphate in MSWI residues (Kirkelund et al., 2010; Jensen et al., 2010, 2015).

The other two based on their pH range tolerance (0–14):

- Ralex® (cationic: CM-PP, anionic: AM-PP), from MEGA a.s. (Czech Republic).
- Excellion™ (cationic: I-100, anionic: I-200), from SnowPure, LLC (United States).

The pH range is a crucial criterion because of the pH differences between the compartments. MSWI residues, found in compartment III, had a considerable alkalinity (Quina et al., 2008a; Kirkelund et al., 2015; Jensen et al., 2015). Contrarily, the solutions in the other compartments were kept in an acidic range as explained in Section 2.5.

Common commercial applications of these IEMs are the deionisation of food products like juices or whey, water and wastewater desalination, as well as electro-coating of automotive parts. Moreover, Ionics membranes have been used in research fields like phosphorus recovery from sewage sludge ashes (Guedes et al., 2016) or heavy metal removal from contaminated soils (Jensen et al., 2007b; Vitale et al., 1997).

2.5. Experiments

Combining the two MSWI residues studied and the four IEMs selected, eight different combinations of ED experiments were replicated until enough ED treated material was produced to carry

out the analyses described in Section 2.2. The duration of the ED treatments was 70 min at a current density of 4.67 mA/cm². Voltage and current between the two electrodes were monitored during the whole experiment. The pH (for all compartments) and electrical conductivity (for compartment III) were measured at the beginning, at the end, and every 20 min during the ED treatment. During the experiments, the pH of the compartment IV (Fig. 1) was adjusted to <2.5 with HNO₃ 1 M, to avoid precipitations in the electrolyte due to the production of OH⁻ from electrolysis at the cathode.

Electrolyte samples were taken at the beginning and at the end of all experiments for each compartment in order to study the metal ion mobility among them. At the end of the experiments, the suspension in the central compartment was filtered at atmospheric pressure and dried during 48 h at 50 °C. The resulting residue was loosened by hand in a mortar and stored in plastic bags under dry conditions. The volumes of the filtered liquid from the middle compartment and the electrolytes were measured. The electrodes were rinsed in 5 mol L⁻¹ HNO₃, whereas the IEMs and the stirrer in 1 mol L⁻¹ HNO₃. The samples of compartments III and IV were diluted at a ratio of 1.25 with concentrated HNO₃, and heated at 200 kPa (120 °C) for 30 min, prior to the metal content analyses in all liquids on ICP-OES (Varian 720-ES ICP-OES).

2.6. Calculations

Mass balances for each studied metal, defined as the relation between the sum of mass found in the different ED cell compartments at the end of the experiments and the amount initially found in the mass of untreated MSWI residue placed in the ED cell, were made to control the quality of the experiments.

An analysis of variances (ANOVA) was run for each element and each treated MSWI residue, so as to evaluate whether the leachability changes after the ED treatment was influenced by the IEM used.

3. Results and discussion

3.1. ED experiments performance

During the ED remediation with one IEM brand (Excellion), liquid flows between the compartments were observed in all experiments. After contacting the manufacturer, it was determined that the membranes were degraded during the ED experiments due to the use of nitrate solutions in the electrolyte compartments (I, II and IV). Specifically, it was detected that a water permeability as high as 0.01327 mL min⁻¹ cm⁻² psi⁻¹ (the normal value would be below 0.0005 mL min⁻¹ cm⁻² psi⁻¹). Thus, the transport mechanisms of ions between compartments might not be dominated by electromigration, as it can be assumed for the other three IEMs. In consequence, this IEM brand was proven not to be suitable for the present ED remediation of these MSWI residues, and its results are not further analysed. The other IEMs did not present major issues during the experiments.

The mass balances of the studied metals, defined as the recovered amount of an element in percentage of the initial amount, was mainly found in a range of 80–120%. This indicates an acceptable quality of the experiments and the validity of the results presented.

The conductivity in compartment III was stable during the ED experiments (results not shown). For the SD, the values oscillated between 40 and 50 mS/cm, whereas for FA the values oscillated between 25 and 30 mS/cm, with a slight tendency for decrease over the 70-min experiments for both residues. The higher conductivity in SD than in FA experiments is probably due to a higher presence of leached elements from the residues: water solubility was found

to be higher for SD (45.6%) than FA (12.5%). Furthermore, water soluble chloride content was almost three times higher in SD than in FA before ED (Table 1). Thus, solubilised anions and cations are likely to be higher in the ED experiments with SD residues. The decrease in the electrical conductivity during the experiments is due to the migration of ions from the suspension into the cathode and the anode compartments. Similar trends were found in previous works with APC residues from REFA (Kirkelund et al., 2010; Jensen et al., 2010). As a consequence of the electrical conductivity decrease in compartment III, voltage increased during all experiments by up to 30%. pH in compartment III was stable and between 11 and 12 during ED remediation for both residues, which is due to the high alkalinity of the MSWI residues.

3.2. MSWI residues characteristics before and after ED treatment

All XRPD diffractograms showing the mineralogy of the treated and untreated residues had a high background due to the presence of amorphous material in the MSWI residues, as previously seen in other studies (Eighmy et al., 1995; Pedersen, 2002). The identified minerals were calcite (CaCO_3), anhydrite (CaSO_4), portlandite (Ca(OH)_2) and Quartz (SiO_2) for untreated and treated SD. The same minerals phases, except for SiO_2 , and together with Calcium chloride hydroxide (CaOHCl), Halite (NaCl) and Sylvite (KCl) were identified for untreated FA. All these phases are consistent with the results from the literature for these two kinds of MSWI residues (Eighmy et al., 1995; Pedersen, 2002; Quina et al., 2008b; Kirby and Rimstidt, 1993; Fermo et al., 1999; Lima et al., 2008). After ED treatment of FA, two new main phases, (gypsum ($\text{CaSO}_4 \cdot \text{H}_2\text{O}$) and SiO_2) were found, whereas soluble phases like NaCl and KCl were not identified. Also, XRD characteristic peaks for Ca(OH)_2 had lower intensity for SD and were not detected for FA after the ED experiments; similarly, CaOHCl peaks disappeared after ED treatment of FA. These results indicate that a considerable part of NaCl , KCl , CaOHCl and Ca(OH)_2 dissolved during ED. Anhydrite intensity peak increased after all ED treatments, which can be attributed to a higher proportion due to its low solubility and the removal of other compounds.

Table 1 show the metal and the soluble salts content of both MSWI residues before and after ED. Overall, and as seen in a previous study (Kirkelund et al., 2010), the total concentration of all metals except Na increased slightly, whereas Cl and SO_4 content

were considerably reduced after the ED experiments (Table 1). These facts confirm that water-soluble salts, like NaCl , and KCl for both residues, and possibly Na_2SO_4 for FA, in the untreated residues, were dissolved and removed during ED. Despite their dissolution, Na as well as the water-soluble part of Cl and SO_4 were, together with Al, Ca, Pb and Zn, the major compounds found for both MSWI residues before and after ED treatment.

3.3. Leaching of elements

3.3.1. General behaviour before and after ED treatment

Tables 2 and 3 show the results from the leaching tests. Category 3 values, the Danish guideline levels for water leachable metals and salts for the reuse of residues as in construction materials (Danish Ministry of Environment, 2010), are also included. MSWI FA/APC residues are generally classified as hazardous and thus these legislation limits would not be applicable, but they can be used as reference to understand the upgrade made after ED experiments.

Ba, Pb and Zn leaching was considerably lower in FA than in SD (Tables 2 and 3), even though their content was similar (Table 1). One reason can be a higher concentration of more alkaline soluble compounds containing either of these elements in SD, such as PbCl_2 , PbO (Nagib and Inoue, 2000), ZnCl_2 (previously identified in MSWI residues (Quina et al., 2008b)) or BaCl_2 . Another explanation can be the lower pH at the end of the leaching test in FA than in SD (Tables 2 and 3): previous researches showed a lower leaching of Ba, Pb and Zn at pH 11 than at pH 12 in MSWI residues (Kirkelund et al., 2015; Quina et al., 2009; Astrup et al., 2006; Hyks et al., 2007).

Overall, average leaching for metals and salts was reduced during ED treatment, a tendency also observed in previous researches on ED remediation of FA and APC residues (Kirkelund et al., 2010, 2015; Jensen et al., 2010; Jensen et al., 2015). The explanation for this trend can be the dissolution and consequent removal to the electrolyte compartments (I, II and IV in Fig. 1) of the leachable part during the ED treatment. Moreover, ions migration through the IEMs can enhance the dissolution of some compounds by equilibrium displacement. Leaching was reduced, on average, from above to below Category 3 limits for Ba and Na in SD and for As, Na, Zn, Cl, SO_4 in FA. Na and Cl leaching reduction are consistent with the decrease in total concentrations (Table 1). Average leaching values were also reduced from above to below Category 3 limits for As in SD regardless the IEM used, as well as for Pb in FA treated with Ralex IEMs.

Notable exceptions were Cr and Ni for both SD and FA, as the leaching increased after the ED experiments, in some cases from below to above Category 3 limits (Tables 2 and 3). The other exception was SO_4 in SD, with a leaching slightly higher after ED treatment. For each element, a separate discussion is needed:

- The increase of Cr leaching after the experiments was also observed in previous researches for ED remediation of similar FA and APC residues (Kirkelund et al., 2010, 2015; Jensen et al., 2015). Cr-solubility in SD and FA has been suggested in other researches to be controlled rather by the presence of sparingly-soluble Cr(VI) phases, like BaCrO_4 and PbCrO_4 , than by Cr(III) phases (Quina et al., 2008b; Van Praagh and Persson, 2008). In fact, the solubility of these Cr(VI) compounds at a high pH is higher than for Cr(III). For instance, an alkaline extraction of PbCrO_4 -spiked soils at L/S 20 released up to 50,000 $\mu\text{g Cr/L}$ (Vitale et al., 1997); in contrast, Cr(III) solubility at pH-12 is limited to around 10 $\mu\text{g/L}$ (Rai et al., 1989). The increase in Cr solubilisation after ED can be due to the removal of soluble Ba and Pb compounds, other than chromates: leaching values of Pb for both residues, and Ba in SD, were noticeably reduced after ED treatment (Tables 2 and 3). Ba and Pb ions scarcity in the

Table 1

Metal and water-soluble salt anion content of SD and FA (mean value \pm standard deviation). The results after ED are calculated as an average of the results of the three IEMs.

| Compound (Units) | SD | | FA | |
|----------------------|-----------------|-----------------|-----------------|-----------------|
| | Before ED | After ED | Before ED | After ED |
| Al (g/kg) | 15.5 \pm 0.09 | 21.4 \pm 1.11 | 29.4 \pm 0.36 | 35 \pm 0.74 |
| As (mg/kg) | 57.7 \pm 2.13 | 68.4 \pm 5.98 | 86 \pm 2.19 | 95.5 \pm 5.02 |
| Ba (mg/kg) | 374 \pm 6.35 | 409 \pm 24.2 | 692 \pm 19 | 797 \pm 49.6 |
| Ca (g/kg) | 296 \pm 3.52 | 301 \pm 11.7 | 186 \pm 2.98 | 198 \pm 5.84 |
| Cd (mg/kg) | 134 \pm 0.78 | 162 \pm 16.6 | 95.3 \pm 1.37 | 107 \pm 4.99 |
| Cr (mg/kg) | 104 \pm 0.87 | 125 \pm 7.54 | 97.2 \pm 5.17 | 109 \pm 4.15 |
| Cu (mg/kg) | 519 \pm 3.94 | 662 \pm 31.2 | 712 \pm 5.87 | 879 \pm 134 |
| Mn (mg/kg) | 352 \pm 10.4 | 480 \pm 13 | 649 \pm 10.2 | 739 \pm 14.2 |
| Mo (mg/kg) | 35.5 \pm 0.49 | 43.1 \pm 2.05 | 55.4 \pm 0.87 | 63.2 \pm 3.05 |
| Na (g/kg) | 32.5 \pm 0.68 | 5.38 \pm 0.37 | 34.6 \pm 0.32 | 5.88 \pm 0.11 |
| Ni (mg/kg) | 27.2 \pm 1.13 | 33.3 \pm 4.23 | 48.5 \pm 10.3 | 47 \pm 3.6 |
| Pb (g/kg) | 2.36 \pm 0.03 | 2.38 \pm 0.14 | 2.90 \pm 0.05 | 2.70 \pm 0.09 |
| V (mg/kg) | 35.1 \pm 0.78 | 40.7 \pm 2.61 | 46.2 \pm 3.01 | 56.7 \pm 6.04 |
| Zn (g/kg) | 15.8 \pm 0.26 | 21.1 \pm 1.21 | 20.7 \pm 0.08 | 23.1 \pm 1.02 |
| Cl (g/kg) | 160 \pm 2.15 | 15.5 \pm 1.10 | 60.7 \pm 1.63 | 2.41 \pm 0.11 |
| SO_4 (g/kg) | 14.9 \pm 0.03 | 10.7 \pm 0.37 | 34.3 \pm 0.98 | 14.7 \pm 0.35 |

Table 2
Metal and salt leaching results from SD according to DS/EN 12457-1 (mean value \pm standard deviation). Average values exceeding Category 3 limits are shown in bold. *Below ICP limit of detection (0.02 mg/L, LOD) ** Range of average values.

| | Before ED | After ED | | | Previous research (Jensen et al., 2015) | | Category 3 (Danish Ministry of Environment, 2010) |
|-----------------------|--------------------------------|----------------------------------|----------------------------------|----------------------------------|---|----------------|---|
| | | Ionic | Neosepta | Ralex | Before ED | After ED ** | |
| pH | 12.3 \pm 0.04 | 12.1 \pm 0.01 | 12.1 \pm 0.01 | 12.1 \pm 0.08 | 11.9 | 10.2–12.2 | – |
| As (μ g/L) | 91 \pm 15 | 43 \pm 16 | 36 \pm 4.2 | 48 \pm 25 | <91 | <20–650 | 50 |
| Ba (mg/L) | 21 \pm 4.4 | 1.7 \pm 0.14 | 1.7 \pm 0.08 | 1.6 \pm 0.14 | 17 \pm 5 | 1.6–3.0 | 4 |
| Cd (μ g/L) | <20* | <20* | <20* | <20* | <20 | <20 | 40 |
| Cr (μ g/L) | 64 \pm 15 | 1200 \pm 45 | 760 \pm 40 | 880 \pm 77 | 61 \pm 2 | 114–1015 | 500 |
| Cu (μ g/L) | 1200 \pm 1500 | 61 \pm 4.0 | 55 \pm 5.7 | 240 \pm 15 | 889 \pm 397 | 32–141 | 2000 |
| Mn (μ g/L) | 100 \pm 160 | <20* | <20* | <20* | <100 | <20 | 1000 |
| Na (g/L) | 14 \pm 2.1 | 1.1 \pm 0.04 | 1.2 \pm 0.05 | 1.1 \pm 0.09 | 13 \pm 2 | 1.6–7.8 | 1.5 |
| Ni (μ g/L) | <20* | 110 \pm 13 | 86 \pm 6.9 | 56 \pm 5.1 | <20 | <20–72 | 70 |
| Pb (mg/L) | 570 \pm 77 | 4 \pm 0.03 | 3.5 \pm 0.81 | 14 \pm 1.3 | 453 \pm 168 | 1–21 | 0.1 |
| Zn (mg/L) | 39 \pm 3.9 | 4.5 \pm 0.13 | 4.4 \pm 0.45 | 6 \pm 0.41 | 32 \pm 10 | 0.1–3.7 | 1.5 |
| Al (μ g/L) | 930 \pm 120 | 360 \pm 71 | 270 \pm 14 | 220 \pm 280 | – | – | – |
| Ca (g/L) | 32 \pm 4.7 | 4.8 \pm 0.13 | 4.9 \pm 0.2 | 4.7 \pm 0.43 | – | – | – |
| Mo (μ g/L) | 770 \pm 57 | 600 \pm 23 | 600 \pm 16 | 550 \pm 50 | 770 | 211–708 | – |
| V (μ g/L) | <20* | <20* | <20* | <20* | <20 | 311–662 | – |
| Cl (g/L) | 85 \pm 1.7 | 8.3 \pm 0.25 | 8.9 \pm 0.26 | 8.7 \pm 0.36 | 87 \pm 3 | 5.1–35 | 3 |
| SO ₄ (g/L) | 0.87 \pm 0.03 | 1.3 \pm 0.03 | 1.3 \pm 0.01 | 1.3 \pm 0.03 | 0.9 \pm 0 | 0.9–1.2 | 4 |

Table 3
Metal and salt leaching results from FA according to DS/EN 12457-1 (mean value \pm standard deviation). Average values exceeding Category 3 limits are shown in bold. *Below ICP LOD. ** One of the triplicate measurements value below LOD, so the result is shown as an average of the other two triplicates and LOD/2.

| | Before treatment | After treatment | | | Previous research (Jensen et al., 2015) | | Category 3 (Danish Ministry of Environment, 2010) | |
|-----------------------|----------------------------------|-----------------------------------|-----------------------------------|--------------------------------|---|---------------------------------|---|------|
| | | Ionic | Neosepta | Ralex | Before ED | After ED | | |
| pH | 11.3 \pm 0.24 | 11.1 \pm 0.01 | 11.1 \pm 0.01 | 11.0 \pm 0.03 | 12.6 | 10.1 \pm 0.1 | 11.9 \pm 0.4 | – |
| As (μ g/L) | 59 \pm 20 | 40 \pm 14 | 36 \pm 2.8 | 48 \pm 22 | <20 | <20 | <29 | 50 |
| Ba (mg/L) | 0.46 \pm 0.05 | 0.29 \pm 0.02 | 0.3 \pm 0.003 | 0.22 \pm 0.02 | 0.4 \pm 0.03 | 0.8 \pm 0.9 | 2.6 \pm 0.1 | 4 |
| Cd (μ g/L) | <20* | <20* | <20* | <20* | <20 | <20 | <20 | 40 |
| Cr (μ g/L) | 18 \pm 7.5** | 430 \pm 44 | 480 \pm 49 | 460 \pm 46 | 20 \pm 0 | 991 \pm 234 | 341 \pm 146 | 500 |
| Cu (μ g/L) | 30 \pm 6.4 | 26 \pm 1.7 | 20 \pm 3 | 16 \pm 3.5 | 23 \pm 11 | 37 \pm 14 | 28 \pm 25 | 2000 |
| Mn (μ g/L) | <20* | <20* | <20* | <20* | <20 | <20 | <20 | 1000 |
| Na (g/L) | 12 \pm 0.8 | 0.43 \pm 0.02 | 0.46 \pm 0.02 | 0.5 \pm 0.04 | 14 \pm 2 | 3.6 \pm 1.1 | 3.1 \pm 0.6 | 1.5 |
| Ni (μ g/L) | <20* | 130 \pm 21 | 140 \pm 7.7 | 75 \pm 8.4 | <20 | <193 | <47 | 70 |
| Pb (mg/L) | 18 \pm 2.4 | 0.47 \pm 0.74 | 0.13 \pm 0.13 | 0.03 \pm 0.01 | 40 \pm 2 | 1.8 \pm 2.2 | 18 \pm 11 | 0.1 |
| Zn (mg/L) | 4.5 \pm 0.67 | 0.57 \pm 0.26 | 0.46 \pm 0.13 | 0.27 \pm 0.02 | 3.3 \pm 1.1 | 0.2 \pm 0.0 | 3.5 \pm 2.8 | 1.5 |
| Al (μ g/L) | 610 \pm 44 | 1100 \pm 130 | 1000 \pm 96 | 150 \pm 14 | – | – | – | – |
| Ca (g/L) | 1.4 \pm 0.07 | 0.97 \pm 0.01 | 0.98 \pm 0.01 | 0.93 \pm 0.06 | – | – | – | – |
| Mo (μ g/L) | 2000 \pm 150 | 640 \pm 27 | 660 \pm 14 | 630 \pm 48 | 2024 \pm 48 | 704 \pm 76 | 497 \pm 16 | – |
| V (μ g/L) | <20* | <20* | <20* | <20* | 4 \pm 55 | 135 \pm 177 | 264 \pm 339 | – |
| Cl (g/L) | 31 \pm 0.21 | 1.4 \pm 0.03 | 1.4 \pm 0.02 | 1.6 \pm 0.06 | 31 \pm 1 | 14 \pm 11 | 20 \pm 7 | 3 |
| SO ₄ (g/L) | 8.4 \pm 0.30 | 1.6 \pm 0.004 | 1.7 \pm 0.04 | 1.8 \pm 0.04 | 9 \pm 0.5 | 1.9 \pm 0.4 | 1.0 \pm 0.4 | 4 |

leaching experiments after ED treatment can favour Cr dissolution. On the contrary, the higher concentration of Ba and/or Pb ions in the untreated residues leaching experiments may prevent the dissolution, or re-precipitate in case of release, of Ba- and Pb-chromates.

- Ni leaching increase was not generally observed before in others researches using ED to remediate similar MSWI FA and APC residues (Kirkelund et al., 2010; Jensen et al., 2015). The reason can be the enhanced dissolution of Al–Ni layered double hydroxide (LDH), which was found to limit Ni solubility in cement materials (Scheidegger et al., 2000), during ED: mobilized Al during the experiments is around 20 and 50 times higher than in the leaching tests of untreated SD and FA, respectively. Thus, a higher dissolution of Al could imply a partial dissolution of Ni hydroxides, which have a higher solubility than in Al–Ni LDH.
- SO₄ leaching increase after ED treatment of SD, which was previously observed in another study for the same APC residues (Jensen et al., 2015) and Table 2, can be due to the removal of soluble Ca compounds during ED: Ca leaching in SD was

considerably reduced (Table 2) after ED. The higher presence of Ca cations in the untreated than ED-treated SD leaching test can decrease CaSO₄ solubility in the former. After ED treatment, the lower content of Ca in the leaching tests can favour CaSO₄ dissolution.

3.3.2. Comparison with previous results, category 3 guidelines and certified coal fly ash values

Compared with a previous study on the same MSWI residues (Jensen et al., 2015), the leaching values before the ED treatment were within two standard deviations for all elements, except for Pb in FA which were still in the same order of magnitude (Tables 2 and 3). Leaching values for untreated SD and FA were also in the same order of magnitude for Cr, Cu, Pb and Zn as another investigation about the same residues (Kirkelund et al., 2015). After ED, leaching of most elements were in the range of the results in (Jensen et al., 2015) (in which Neosepta was used) for SD (Table 2), and within two standard deviations for FA (Table 3). Moreover, they had the

same order of magnitude for Cr, Cu, Pb and Zn than the values obtained in (Kirkelund et al., 2015) with a 3-compartment ED cell using Ionics. Therefore, the leaching values before and after ED were in line with previous investigations.

For SD, Category 3 limits were exceeded on average for Cr, Pb, Zn and Cl after treatment regardless the IEM used and for Ni after treatment using Ionics and Neosepta IEMs (Table 2). The variability of As values was high enough for Ionics and Neosepta IEMs, so that Category 3 limits could be exceeded or not within one standard deviation (Table 2). For FA, Category 3 limits were exceeded on average for Pb after treatment with Ionics and Neosepta IEMs; remarkably, Category 3 limits were within one standard deviation below the mean value for both IEM (Table 3). Category 3 limits were also slightly exceeded on average for Ni after ED treatment with the three IEMs. It should be noted that there was variability enough for Cr for all IEMs, for Ni with Ralex and for As with Ionics and Ralex to exceed or not Category 3 limits within one or two standard deviations (Table 3). Leaching values exceeding Category 3 for Pb, Zn and Cl were observed in a previous work with APC residues from the REFA plant (Kirkelund et al., 2010); in that research, the combination of the ED treatment with carbonation was successful in order to reduce the leachability for most of heavy metals except for Cr. A similar treatment could have a potential beneficial effect for the two MSWI residues of this study, although it requires further study.

Certified coal fly ash is commonly used in cement production, in contrast to MSWI APC residues, despite that its Cr leaching values normally exceeds Category 3 limits leaching values (Kirkelund et al., 2014). In general, considering a range of two standard deviations, ED treated SD and FA have a higher metal leaching than certified coal fly ashes. Exceptions for treated FA were Al, Ba, Ca and Cr, as their leaching in coal fly ashes is higher: 2600 µg/L, 0.7 mg/L, 1200 g/L and 1000 µg/L (Kirkelund et al., 2014), respectively (see Table 3 for comparison). For treated SD, the exceptions were Al and Cr for some IEMs (see Table 2 for comparison).

3.3.3. Difference in leaching values among the IEMs

The result of the ANOVA among the different ED treatments for each residue with a P-value > 0.05 showed that mean leaching values were found not to be the same for some of the elements among the three IEMs studied. More specifically, mean leaching values of Cr, Cu, Ni, Pb and Zn for the treated SD, and Ba, Cu, Ni, Al, Cl and SO₄ for the treated FA were found to be different depending on the IEM used. It is worth mentioning that Pb and Zn leaching values had a high variability for FA treated with Ionics and Neosepta IEMs (Table 3), which requires further study. The reason could not be the pH of the different leachates, since they were almost identical regardless the membrane used (Tables 2 and 3).

Main differences were found for Pb in SD: leaching after ED treatment with Ralex was around 3 to 4 times higher than with the other two IEMs (Table 2). The reason can be a different transportation rate of chloride anions through the IEMs. Ralex IEMs are likely to transport Cl⁻ at a slower rate than Ionics and Neosepta. This can be seen in the water soluble Cl content for both residues, which was slightly higher after ED treatment with Ralex than with Ionics or Neosepta: 17.0, 15.6 and 15.0 mg/kg for SD and 2.54, 2.36 and 2.32 mg/kg for FA, respectively. A slower migration of Cl through Ralex IEMs can entail a lower dissolution of PbCl₂ by equilibrium displacement, and, consequently, the content of sparingly soluble PbCl₂ in SD after ED treatment with Ralex can be higher than when using Ionics or Neosepta. However, the transportation of Cl⁻ and the other species through the different IEM brands, and its connection to differences in leachability, require specific research for proper confirmation.

4. Conclusions

The leaching of some heavy metals and salts in two MSWI residues was found to be different after ED treatment depending on the IEM brand used, without achieving a better overall result for any of them. Further investigation is required in order to understand the unalike transportation of chloride and other ions among different IEMs during ED, and its influence in the leaching behaviour of the hazardous elements from MSWI residues.

ED remediation resulted in the reduction of the leachability for most heavy metals and salts, probably due to the removal of the leachable part. For some metals, like Al or Cr, the leaching was reduced to below the values found in certified coal fly ash. At the same time, leaching was reduced for some elements like As from above to below the Danish guideline levels for the use of residues as construction materials. However, none of the resulting ED-treated MSWI residues had all the leaching values below these levels, and for most elements the final values were higher than for certified coal fly ash.

Acknowledgements

The Danish Environmental Protection Agency (Ministry of Environment and Food of Denmark) is acknowledged for funding this research as part of the project "Electrodialytic upgrading of MSWI APC residue from hazardous waste to secondary resource".

References

- Akgemci, E.G., Ersoz, M., Atalay, T., 2005. Comparison of commercial anion-exchange membranes for pickle waste treatment by electro-electrodialysis. *Sep. Sci. Technol.* 40 (4), 1899–1909.
- Astrup, T., Mosbæk, H., Christensen, T.H., 2006. Assessment of long-term leaching from waste incineration air-pollution-control residues. *Waste Manag.* 26 (8), 803–814.
- Danish Standard, 2002. Characterisation of Waste - Leaching - Compliance Test for Leaching of Granular Waste Materials and Sludges - Part 1: One Stage Batch Test at a Liquid to Solid Ratio of 2 L/kg for Materials with High Solid Content and with Particle Size below 4 Mm (Without or with Size Reduction).
- Danish Standard, 2003. DS259: Determination of Metals in Water, Sludge and Sediments - General Guidelines for Determination by Atomic Absorption Spectrophotometry in Flame.
- Danish Standard, 2009. Water Quality - Determination of Dissolved Anions by Liquid Chromatography of Ions - Part 1: Determination of Bromide, Chloride, Fluoride, Nitrate, Nitrite, Phosphate and Sulfate.
- Danish Ministry of Environment, 2010. Bekendtgørelse om Anvendelse af Restprodukter og Jord Til Bygge- og Anlægsarbejder og om Anvendelse af Sorteret, Uforurenset Bygge- og Anlægsaffald BEK nr 1662 af 21/12/2010 (In Danish).
- Eighmy, T.T., et al., 1995. Comprehensive approach toward understanding element speciation and leaching behavior in municipal solid-waste incineration electrostatic precipitator ash. *Mar Environ. Sci. Technol.* 29 (3), 629–646.
- Fermo, P., et al., 1999. The analytical characterization of municipal solid waste incinerator fly ash: methods and preliminary results. *Dec Fresenius J. Anal. Chem.* 365 (8), 666–673.
- Ferreira, C., Ribeiro, A., Ottosen, L., 2003. Possible applications for municipal solid waste fly ash. *Jan J. Hazard. Mater.* 96 (2–3), 201–216.
- Ferreira, C., Jensen, P., Ottosen, L., Ribeiro, A., 2005. Removal of selected heavy metals from MSW fly ash by the electro-dialytic process. *Mar Eng. Geol.* 77 (3–4), 339–347. Article; Proceedings Paper.
- Gong, Y., Dai, L.-M., Wang, X.-L., Yu, L.-X., 2006. Effects of transport properties of ion-exchange membranes on desalination of 1,3-propanediol fermentation broth by electrodialysis. *Desalination* 191 (1–3), 193–199.
- Guedes, P., Couto, N., Ottosen, L.M., Kirkelund, G.M., Mateus, E., Ribeiro, A.B., 2016. Valorisation of ferric sewage sludge ashes: potential as a phosphorus source. *Waste Manag.* 52, 193–201.
- Hoorweg, D., Bhada-Tata, P., 2012. What a waste: a global review of solid waste management. In: *Urban Development Series*.
- Hyks, J., Astrup, T., Christensen, T.H., 2007. Influence of test conditions on solubility controlled leaching predictions from air-pollution-control residues. *Waste Manag. Res.* 25 (5), 457–466.
- Jensen, P.E., Ottosen, L.M., Ferreira, C., 2007a. "Electrodialytic remediation of soil fines (< 63 µm) in suspension - influence of current strength and L/S. *Feb Electrochim. Acta* 52 (10), 3412–3419. Article; Proceedings Paper.
- Jensen, P.E., Ottosen, L.M., Ferreira, C., 2007b. Electrodialytic remediation of soil fines (< 63 µm) in suspension - influence of current strength and L/S. *Feb Electrochim. Acta* 52 (10), 3412–3419. Article; Proceedings Paper.

- Jensen, P.E., Ferreira, C.M.D., Hansen, H.K., Rype, J.U., Ottosen, L.M., Villumsen, A., 2010. Electromediation of air pollution control residues in a continuous reactor. *Jun J. Appl. Electrochem.* 40 (6), 1173–1181. Article; Proceedings Paper.
- Jensen, P.E., Kirkelund, G.M., Pedersen, K.B., Dias-Ferreira, C., Ottosen, L.M., 2015. Electrolytic upgrading of three different municipal solid waste incineration residue types with focus on Cr, Pb, Zn, Mn, Mo, Sb, Se, V, Cl and SO₄. *Electrochim. Acta* 181, 167–178.
- Kirby, C.S., Rimstidt, J.D., 1993. Mineralogy and surface-properties of municipal solid-waste ash. *Apr Environ. Sci. Technol.* 27 (4), 652–660.
- Kirkelund, G.M., Jensen, P.E., Villumsen, A., Ottosen, L.M., 2010. Test of electrolytic upgrading of MSWI APC residue in pilot scale: focus on reduced metal and salt leaching. *Jun J. Appl. Electrochem.* 40 (6), 1049–1060. Article; Proceedings Paper.
- Kirkelund, G.M., Jensen, P.E., Ottosen, L.M., 2013. Electrolytic extraction of heavy metals from greenlandic MSWI Fly Ash as a function of remediation time and L/S ratio. In: *ISCOR 2013: Planning for Sustainable Cold Regions - Proceedings of the 10th International Symposium on Cold Regions Development*, pp. 87–96.
- Kirkelund, G.M., Geiker, M.R., Jensen, P.E., 2014. Electrolytically treated MSWI APC residue as substitute for cement in mortar. *Nord. Concr. Res.* 49, 1–16.
- Kirkelund, G.M., Magro, C., Guedes, P., Jensen, P.E., Ribeiro, A.B., Ottosen, L.M., 2015. Electrolytic removal of heavy metals and chloride from municipal solid waste incineration fly ash and air pollution control residue in suspension - test of a new two compartment experimental cell. *Electrochim. Acta* 181, 73–81.
- Lima, A.T., Ottosen, L.M., Pedersen, A.J., Ribeiro, A.B., 2008. Characterization of fly ash from bio and municipal waste. *Mar Biomass & Bioenergy* 32 (3), 277–282.
- Nagib, S., Inoue, K., 2000. Recovery of lead and zinc from fly ash generated from municipal incineration plants by means of acid and/or alkaline leaching. *Hydrometallurgy* 56 (3), 269–292.
- Nystroem, G.M., Ottosen, L.M., Villumsen, A., 2005. Electrolytic removal of Cu, Zn, Pb, and Cd from harbor sediment: influence of changing experimental conditions. *Apr Environ. Sci. Technol.* 39 (8), 2906–2911.
- Pedersen, A.J., 2002. Electrolytic Removal of Heavy Metals from Fly Ashes (PhD thesis). Technical University of Denmark (DTU).
- Pedersen, A.J., Ottosen, L.M., Villumsen, A., 2003. Electrolytic removal of heavy metals from different fly ashes - influence of heavy metal speciation in the ashes. *Jun J. Hazard. Mater.* 100 (1–3), 65–78.
- Pedersen, A.J., Ottosen, L.M., Villumsen, A., 2005. Electrolytic removal of heavy metals from municipal solid waste incineration fly ash using ammonium citrate as assisting agent. *Jun J. Hazard. Mater.* 122 (1–2), 103–109.
- Quina, M.J., Bordado, J.C., Quinta-Ferreira, R.M., 2008a. Treatment and use of air pollution control residues from MSW incineration: an overview. *Nov Waste Manag.* 28 (11), 2097–2121.
- Quina, M.J., Santos, R.C., Bordado, J.C., Quinta-Ferreira, R.M., 2008b. Characterization of air pollution control residues produced in a municipal solid waste incinerator in Portugal. *Apr J. Hazard. Mater.* 152 (2), 853–869.
- Quina, M.J., Bordado, J.C.M., Quinta-Ferreira, R.M., 2009. The influence of pH on the leaching behaviour of inorganic components from municipal solid waste APC residues. *Waste Manag.* 29 (9), 2483–2493.
- Rai, D., Eary, L.E., Zachara, J.M., 1989. Environmental chemistry of chromium. *Sci. Total Environ.* 86 (1–2), 15–23.
- Sabbas, T., et al., 2003. Management of municipal solid waste incineration residues. *Waste Manag.* 23 (1), 61–88.
- Scheidegger, A.M., Wieland, E., Scheinost, A.C., Dahn, R., Spieler, P., 2000. Spectroscopic evidence for the formation of layered Ni-Al double hydroxides in cement. *Nov Environ. Sci. Technol.* 34 (21), 4545–4548.
- Ulises, L.-G., René, A.-L., German, O., Julieta, T.-G., Federico, C., 2011. Comparison of nine membrane pairs for electrolytic removal of nitrate ions. *J. Water Resour. Prot.* 03 (06).
- Van Praagh, M., Persson, K.M., 2008. Metal releases from a municipal solid waste incineration air pollution control residue mixed with compost. *Aug Waste Manag. Res.* 26 (4), 377–388.
- Vitale, R.J., Mussoline, G.R., Rinehimer, K.A., Petura, J.C., James, B.R., 1997. Extraction of sparingly soluble chromate from soils: evaluation of methods and E(h)-pH effects. *Environ. Sci. Technol.* 31 (2), 390–394.

Publication V

Sequential electrodialytic extraction of phosphorus compound (filed with the international application number PCT/EP2016/073094).

Sequential electro dialytic extraction of phosphorus compounds

Field of invention

5 The present invention relates to an apparatus for electro dialytic extraction of phosphorus from a particulate material in suspension, a method for electro dialytic phosphorus recovery, and the use of the apparatus and the method for wastewater treatment, and/or treatment of particulate material rich in phosphorus.

Background of invention

10 Phosphorus (P) is a valuable resource; it is an elemental nutrient for agriculture, as well as an element in food, biofuels and biobased materials. The global consumption of phosphorus, and phosphorus compounds such as phosphate (PO_4^{3-}), is increasing, and thus the supply of phosphorus has received increasing attention during recent years. Phosphorus may be extracted from phosphate rock reserves. The reserves are
15 geographically restricted and a non-renewable resource. The reserves, or primary sources, of phosphorus are estimated to be depleted within a century.

Alternative, also called secondary, phosphorus resources include municipal wastewater and agricultural organic residues, such as livestock manure or digestate from biogas
20 plants. In the wastewater, the phosphorus occurs as dissolved inorganic phosphates in a liquid fraction and/or as phosphorus bound in a solid fraction, e.g. as inorganic precipitates or complexes, or as complex biochemical molecules.

The purpose of wastewater treatment is to remove contaminants from the wastewater
25 to produce an environmentally safe fluid for reuse. The solid, or semi-solid, waste from such a process is called sludge, and depending on the processes it may be characterised as industrial sludge or sewage sludge, and the sludge will thus contain the contaminants. The contaminants may be heavy metals as well as phosphorus compounds. Contaminants such as phosphorus compounds are typically removed
30 from the wastewater by microorganisms combined with chemical precipitation involving the addition of iron (Fe) or aluminium (Al) salts. Thus, sludge typically contains phosphorus bound as inorganic phosphates (Al-, Fe- and Ca-phosphates) and organic bound phosphorus.

The sludge is further typically incinerated to ash, which may be either disposed or reused as e.g. farm fertilizer. However, the ashes containing iron and aluminum phosphates are known to have low fertilizer value, as phosphorus in these chemical forms is not easily accessible for plants. Thus, methods to extract phosphorus from sewage sludge or sewage sludge ashes (also denoted SSA) into phosphorus products with higher fertilizer value are of interest.

Furthermore, in the fertilizer industry it is important to keep the ratios of Al, Fe, and Mg to phosphorus low. This is to obtain industrial phosphoric acid with high concentration, as well as to manufacture common fertilizers like diammonium phosphate (DAP). For this purpose, there is a technical limit called minor element ratio (MER), defined as:

$$MER = \frac{Al_2O_3 + Fe_2O_3 + MgO}{P_2O_5} < 0.085$$

Recently, electrodialysis or electro-dialytic remediation has been used to produce phosphorus products from ashes. WO 2015/032903 [1] discloses a two compartment electrochemical cell, where the two compartments are separated by a cation exchange membrane. A particulate suspension, such as an ash comprising heavy metals, is introduced into the anode compartment. When an electric field is applied, protons are generated at the anode, whereby the different metals (Al, Ca, Fe and heavy metals) dissolve and form positively charged cations that will migrate from the anode compartment, through the cation exchange membrane and into the cathode compartment.

Thus, in [1] the heavy metals are separated from the particulate suspension, and the residual particulate suspension which may contain phosphorus, may be used as an agricultural product. However, the concentration of phosphorus in the liquid part of the residual particulate suspension may be low, and its fertilizer value in the solid part of the residual particulate suspension is low if the phosphorus is found as iron and aluminium phosphates in the original ash.

Furthermore, typically the concentration of phosphorus in the liquid part of the residual particulate suspension is low, because the rate of phosphorus extraction to the liquid part is low, since the main driving forces for the extraction is dissolution and diffusion.

Electrodialytic remediation of a phosphorus containing sludge using a two compartment electrochemical cell with an anion exchange membrane, has been described by B. Ebberts et al. [2]. The sludge, which may comprise phosphorus, is in this case introduced into the cathode compartment. When an electric field is applied, hydroxide anions are formed at the cathode, whereby some of the phosphorus bound in the sludge will dissolve and form negatively charged phosphorus compounds (such as HPO_4^{2-}) that will migrate from the cathode compartment, through the anion exchange membrane and into the anode compartment.

Thus, in [2] the phosphorus is separated from the particulate suspension in the cathode compartment, and concentrated in the anode compartment in a readily available form. However, when using this method, not all phosphorus compounds will dissolve and/or form negatively charged compounds. For example, phosphorus bound to calcium (Ca) is expected to remain as insoluble in the cathode compartment. Thus, the method is not suitable for fully, or high degree of recovery of the phosphorus in the ashes.

Furthermore, typically the concentration of phosphorus in the liquid part of the residual particulate suspension is low, because the rate of phosphorus extraction to the liquid part is low, since the main driving forces for the extraction is dissolution and diffusion.

20

Summary of invention

The present invention provides an apparatus and a method for high recovery of phosphorus from a particulate material, such as a sludge or a sludge ash. Furthermore, the present invention provide extracted phosphorus in a form that can be easily used to manufacture products with high fertilizer value, such as phosphorus in an aqueous solution.

25

The inventors of the present invention have surprisingly found that if modifications are made to the earlier established two compartment electrochemical cell, by combining two separated two compartment cells via filtration means, then an improved remediation method is achieved.

30

In a first aspect the present invention provides an apparatus for electrochemical extraction of phosphorus from a particulate material in suspension, comprising:

35 - a first electrochemical cell comprising

- a first anolyte compartment comprising a first anolyte, and
 - a first catholyte compartment comprising a first catholyte, wherein the compartments of the first cell are separated by a cation exchange membrane, and wherein the first anolyte is the particulate material in suspension;
- 5
- a second electro dialytic cell comprising
 - a second anolyte compartment comprising a second anolyte, and
 - a second catholyte compartment comprising a second catholyte, wherein the compartments of the second cell are separated by an anion exchange membrane; and
- 10
- filtration means in fluid communication with the compartments and configured to filter the first anolyte, and transfer the residual into the second catholyte compartment to be comprised in the second catholyte, and transfer the filtrate into the second anolyte compartment to be comprised in
- 15
- the second anolyte.

In a further aspect, the present invention provides an apparatus for electro dialytic extraction of phosphorus from a particulate material comprising acidic and/or alkaline soluble phosphorus compounds, in suspension, comprising:

- 20
- a first electro dialytic cell, comprising
 - a first anolyte compartment comprising a first anolyte, and
 - a first catholyte compartment comprising a first catholyte, wherein the compartments of the first cell are separated by a cation exchange membrane,
- 25
- wherein the first anolyte is the particulate material in suspension, the first electro dialytic cell configured for exposing the particulate material to acidic conditions;
- a second electro dialytic cell comprising
 - a second anolyte compartment comprising a second anolyte, and
 - a second catholyte compartment comprising a second catholyte, wherein the compartments of the second cell are separated by an anion exchange membrane,
- 30
- the second electro dialytic cell configured for exposing the particulate material to alkaline conditions; and

filtration means in fluid communication with the first and second electrolysytic cells, and configured to filter the first anolyte and transfer the residual into the second catholyte compartment to be comprised in the second catholyte and transfer the filtrate into the second anolyte compartment to be comprised in the second anolyte.

5

In a second aspect the present invention provides a method for electrolysytic phosphorus recovery, comprising:

- (a) providing a first electrolysytic cell, comprising a first anolyte compartment and a first catholyte compartment, separated by a cation exchange membrane;
 - 10 (b) providing a particulate material comprising phosphorus;
 - (c) mixing the particulate material with a liquid and use it as an anolyte for the first cell;
 - (d) providing an electrolyte solution and use it as a catholyte for the first cell;
 - (e) applying a first current to the first cell;
- whereby metal ions are concentrated in the catholyte;
- 15 (f) providing a second electrolysytic cell, comprising a second anolyte compartment and a second catholyte compartment, separated by an anion exchange membrane;
 - (g) transferring the treated anolyte from the first cell by filtration means such that the treated anolyte is filtered into a residual and a filtrate;
 - (h) transferring the liquid filtrate into the second anolyte compartment thereby forming a
 - 20 second anolyte;
 - (i) mixing the residual with water, and transferring it into the second cathode compartment thereby forming a second catholyte;
 - (j) applying a second current to the second cell;
- whereby phosphorus and phosphorous compounds are concentrated in the second
- 25 anolyte.

In a further aspect, the present invention provides a method for electrolysytic phosphorus recovery, comprising:

- (a) providing a first electrolysytic cell, comprising a first anolyte compartment and a
- 30 first catholyte compartment, separated by a cation exchange membrane;
- (b) providing a particulate material comprising acidic and/or alkaline soluble phosphorus compounds;
- (c) mixing the particulate material with a liquid and use it as an anolyte for the first cell;
- (d) providing an electrolyte solution and use it as a catholyte for the first cell;
- 35 (e) applying a first current to the first cell thereby exposing the particulate material to

acidic conditions,

whereby metal ions are concentrated in the catholyte;

(f) providing a second electrochemical cell, comprising a second anolyte compartment and a second catholyte compartment, separated by an anion exchange membrane;

5 (g) transferring the treated anolyte from the first cell to filtration means such that the treated anolyte is filtered into a residual and a filtrate;

(h) transferring the liquid filtrate into the second anolyte compartment thereby forming a second anolyte;

10 (i) mixing the residual with water, and transferring the mixture into the second cathode compartment thereby forming a second catholyte;

(j) applying a second current to the second cell thereby exposing the particulate material to alkaline conditions,

whereby phosphorus and phosphorous compounds are concentrated in the second anolyte.

15

A third aspect of the present invention is directed to the use of the apparatus according to the first aspect, and the use of the method according to the second aspect of the invention, for wastewater treatment and/or treatment of particulate material rich in phosphorus, such as incinerated-, gasified-, and pyrolyzed- wastewater sludge ash.

20

Description of Drawings

The invention will in the following be described in greater detail with reference to the accompanying drawings.

25

Figure 1 shows an embodiment of the invention comprising a first electrochemical cell (1), a second electrochemical cell (2), and filtration means (3). Each cell is a two compartment electrochemical cell, where the charged electrodes, indicated by plus (anode) and minus (cathode) signs, are placed in respectively the anolyte compartments (4, 6) and the catholyte compartments (5, 7). The two compartments in the first cell (1) are separated by a cation exchange membrane (8), and the two compartments in the second cell are separated by an anion exchange membrane (9). Electrolyte solutions and/or suspensions are circulated in the compartments, and the electrolyte/suspension in the anolyte compartments is designated anolyte (4.1, 6.1), and the electrolyte/suspension in the catholyte compartments is designated catholyte (5.1, 7.1).

35

Figure 2 shows an embodiment of the invention where the first catholyte (5.1) is recycled as first catholyte (5.1), and/or the second anolyte (6.1) and/or the first filtrate (3.1) is recycled as a part comprised in the first anolyte (4.1). The embodiment also illustrates a second filtration means (10) in fluid communication with the second catholyte compartment (7), wherein the produced second filtrate (10.1) may be recycled as the liquid comprised in the second catholyte (7.1).

Figure 3 shows the solubility curves of Al-, Fe-, and Ca-phosphates as a function of pH, according to [3].

Figure 4 shows the solubility curves of calcium orthophosphoric compounds at 37° C, depending on pH in aqueous solution. HAp: hydroxyapatite ($\text{Ca}_{10}(\text{PO}_4)_6(\text{OH})_2$), TCP: calcium phosphate ($\text{Ca}_3(\text{PO}_4)_2$), OCP: octacalcium phosphate ($\text{Ca}_8\text{H}_2(\text{PO}_4)_6 \cdot 5\text{H}_2\text{O}$), DCPA: dicalcium phosphate anhydrous (CaHPO_4), DCPD: dicalcium phosphate dihydrate ($\text{CaHPO}_4 \cdot 2\text{H}_2\text{O}$), according to [4].

Figure 5 shows the pH dependence of metal hydroxide solubility, where the considered minerals are $\text{Al}(\text{OH})_3$, $\text{Fe}(\text{OH})_2$, $\text{Fe}(\text{OH})_3$, and $\text{Zn}(\text{OH})_2$, as reported by C. Noubactep in Clean-Soil Air Water 41(5) (2013) p. 493-502 [5].

Detailed description of the invention

The present invention relates to an apparatus and a method for extraction of phosphorus from a particulate material, such as a sludge or a sludge ash. Particulate material such as sludge or sludge ash typically comprise phosphorus bound to Al, Fe and Ca and/or heavy metals. Examples of common phosphorous compounds in sewage sludge and ashes include AlPO_4 , FePO_4 , $\text{Ca}_{10}(\text{PO}_4)_6(\text{OH})_2$, and $\text{Ca}_3(\text{PO}_4)_2$, as well as other less common compounds such as CaHPO_4 , $\text{Ca}_4\text{H}(\text{PO}_4)_3$, and $\text{Ca}_{10}(\text{PO}_4)_6(\text{F})_2$.

Phosphorus refers to the chemical element with symbol P and atomic number 15. Compounds comprising phosphorus are referred to as phosphorous compounds, but may also be referred to as phosphorus species, or abbreviated as "P-compounds". Examples of P-compounds include ortho-phosphates with the general formula

$H_xPO_4^{x-3}$, where x is between 0 and 3, as well as iron-, aluminum-, and Ca-phosphate compounds. By the term “phosphorus” as used herein is meant any material comprising phosphorus in any form, such as elemental form, ionic form, or any compound comprising phosphorus. Thus, the terms “phosphorus compounds” and
5 “phosphorous compounds” may be used interchangeably.

By the term “phosphorous” as used herein is meant any kind of ionic form, which includes elemental phosphorous, such as for example phosphoric acid (H_3PO_4), dihydrogen phosphate ($H_2PO_4^-$), hydrogen phosphate (HPO_4^{2-}), phosphate (PO_4^{3-}),
10 phosphorous acid (H_3PO_3), dihydrogen phosphonate ($H_2PO_3^-$), hydrogen phosphonate (HPO_3^{2-}), phosphonate (PO_3^{3-}) and pyrophosphate ($H_2P_2O_5^{2-}$), as well as $AlPO_4$, $FePO_4$, $Ca_{10}(PO_4)_6(OH)_2$, and $Ca_3(PO_4)_2$. A skilled person would know of any similar ionic forms that phosphorous may be able to form.

15 A suspension is a heterogeneous mixture of solid particles or particular matter dispersed or suspended in a fluid or liquid phase. By the term “particulate matter” as used herein is meant any kind of particulate material that can be suspended and subjected to the novel process of the present invention.

20 In some embodiments the particulate material originates from waste products. Such products often need to be deposit at a secured waste deposit because of the toxic heavy metals. Hence, if the particulate material can be treated before disposal so that the heavy metals are removed prior to depositing, as well as removal of any valuable elements such as phosphorus, then a smaller amount of waste product needs to be
25 deposited.

Examples of waste products that can be subjected to the electrodialytic process of the present invention include sludge ash, manure ash, soil and soil sludge, municipal solid waste incineration air pollution control residue, harbor sediment, sewage sludge,
30 sewage sludge ash (SSA), mine tailings, low quality P-ore, freshwater sediment, slag, bottom ash, fly ash, bioash and industrial/agricultural sludge. In a preferred embodiment the particulate material is a material selected from the group consisting of sludge ash, manure ash, soil and soil sludge, municipal solid waste incineration air pollution control residue, harbor sediment, sewage sludge and sewage sludge ash. In a

particular preferred embodiment the particulate material is sewage sludge ash containing heavy metals as well as calcium-, iron- and/or aluminum phosphates.

5 By the term “heavy metal” as used herein is meant any metal or metalloid that is toxic and thereby dangerous to the health of human beings and animals as well as to the environment. Hence, the term refers to metals that need to be removed from materials before said materials are safe to use as for example agricultural products or the like. Typical examples of heavy metals include As, Ba, Se, Sb, Mo, Cd, Cr, Cu, Ni, Pb, Zn, Sn, Ta, Nb, Zr and any of the lanthanides, as well as Hg.

10

By the term “alkaline soluble phosphorus compounds” is meant phosphorus compounds with a high solubilisation at alkaline pH, i.e. at a pH value above 10. Examples of alkaline soluble phosphorus compounds include Al phosphates and Fe(III) phosphates as seen in Figure 3.

15

By the term “acidic soluble phosphorus compounds” is meant phosphorus compounds with a high solubilisation at acidic pH, i.e. at pH value below 4. Examples of acidic soluble phosphorus compounds include Ca phosphates (e.g. $\text{Ca}_3(\text{PO}_4)_2$) as seen in Figures 3-4, and Mg phosphates.

20

The particulate material to be treated may comprise phosphorus bound in various forms depending on the origin and treatment.

25 Sewage sludge ash from low-T gasification as used in Examples 1-4 typically comprise phosphorus bound to Ca, Al, and Fe. The phosphorus bound to Fe and Al is mainly formed after chemically treatment of the sludge, where Fe and Al salts are typically used for treatment and for capturing phosphorus in the sludge.

The sludge may be turned into ash by gasification, such as low-T gasification, or by incineration.

30

The phosphorus compounds typically remains upon gasification, i.e. the Al-P and Fe(III)-P compounds are still present. However, incineration may affect the phosphorus compounds, such that the phosphorus bound to Al and Fe(III) is decomposed and instead forms Ca-P compounds.

35

Thus, in these cases the particulate material to be electro dialytically treated may comprise phosphorus bound to Ca, Al, and Fe, or mainly phosphorus bound as Ca-P. Sewage sludge may also be chemically treated with other chemicals than Al salts and/or Fe-salts, such as AlCl_3 , and FeCl_3 . An examples of another chemical is $\text{Ca}(\text{OH})_2$, Thus, the particulate material to be electro dialytically treated may comprise phosphorus bound to Al, and/or Fe, and/or Ca.

Examples 1-4 describes electro dialytic treatment of a particulate materials comprising P bound to Ca, Al, and Fe.

Example 5 describes electro dialytic treatment of a particulate materials comprising P bound to mainly Ca.

Example 6 describes electro dialytic treatment of a particulate materials comprising P bound to mainly Ca and Al.

Example 7 describes electro dialytic treatment of a particulate materials comprising P bound to mainly Ca and Fe(III).

Example 8 describes electro dialytic treatment of a particulate materials comprising P bound to mainly Al.

Example 9 describes electro dialytic treatment of a particulate materials comprising P bound to mainly Fe(III).

Even though the starting particulate material comprises mainly phosphorus bound to Ca, phosphorus bound to other components may be formed before or during the electro dialytic treatment. For example part of the Ca-P compounds that are dissolved during electro dialytic treatment at low pH, may reprecipitate as new Al-P or Fe-P compounds.

Similarly, for a starting material comprising no Ca-P compounds, Ca-P compounds may be formed before or during the electro dialytic treatment if Ca is present isolated or as other compounds. Ca may be present since it is used as a sludge stabilizer.

The P-compounds formed before or during the electro dialytic treatment may be due to Al, Fe, and/or Ca being present either isolated or as other compounds used during previous steps of the sludge or wastewater treatment. For example, Al salts may be used in the flocculation step at the wastewater treatment plant, or may be present due to the zeolites present in the wastewater. Similarly, Fe(III) may be present since Fe (III)

salts may be used in the flocculation step at the wastewater treatment plant. Also, Ca may be present due to the use of lime as stabilizer at the wastewater treatment plant.

5 Thus, to ensure maximum potential P recovery, it is advantageous that phosphorus bound to Al, and/or Fe, and/or Ca, formed at various steps of the material treatment can be recovered.

Sequential electro dialytic extraction

10 In an aspect of the current invention, the extraction of phosphorus from a particulate material process is performed sequentially by combining two separated electro dialytic two compartment cells via filtration means. By using the sequential approach, a high degree of the bound phosphorus are extracted, and optionally heavy metals are extracted too.

15 The sequential method for electro dialytic phosphorus recovery, comprises the steps of:

- (a) providing a first electro dialytic cell (1), comprising a first anolyte compartment (4) and a first catholyte compartment (5), separated by a cation exchange membrane (8);
- (b) providing a particulate material comprising phosphorus or phosphorous compounds;
- 20 (c) mixing the particulate material with a liquid and use it as an anolyte for the first cell (4.1);
- (d) providing an electrolyte solution and use it as a catholyte (5.1) for the first cell;
- (e) applying a first current to the first cell (1);

whereby metal ions are concentrated in the catholyte (5.1);

- 25 (f) providing a second electro dialytic cell, comprising a second anolyte compartment (6) and a second catholyte compartment (7), separated by an anion exchange membrane (9);
- (g) transferring the treated anolyte (4.1) from the first cell (1) by filtration means such that the treated anolyte is filtered into a residual and a filtrate (3.1);
- 30 (h) transferring the liquid filtrate (3.1) into the second anolyte compartment (6) thereby forming a second anolyte (6.1);
- (i) mixing the residual with water, and transferring the mixture into the second cathode compartment (7) thereby forming a second catholyte (7.1);
- (j) applying a second current to the second cell (2);

whereby phosphorus and phosphorous compounds are concentrated in the second anolyte (6.1).

5 An illustration of an embodiment of the invention is shown in Figure 1. Figure 1 shows a first electro dialytic cell (1), a second electro dialytic cell (2), and filtration means (3). Each cell is a two compartment electrochemical cell, where the charged electrodes, indicated by plus (anode) and minus (cathode) signs, are placed in respectively the anolyte compartments (4, 6) and the catholyte compartments (5, 7). The two compartments in the first cell (1) are separated by a cation exchange membrane (8), and the two compartments in the second cell are separated by an anion exchange membrane (9). Electrolyte solutions and/or suspensions are circulated in the compartments, and the electrolyte/suspension in the anolyte compartments is designated anolyte (4.1, 6.1), and the electrolyte/suspension in the catholyte compartments is designated catholyte (5.1, 7.1).

15 During the extraction process, an electric field in the form of a direct current is applied to the electrodes of the first cell, and then subsequently to the second cell. In each cell, the current will result in the following electrolytic half-reactions at the electrodes (reaction R1 and R2):

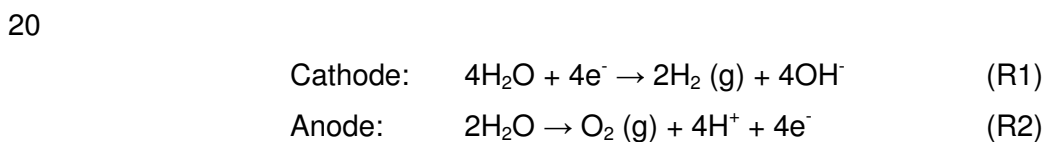

25 From the half-reactions it follows that the pH near a cathode will increase (due to the produced hydroxide ions), and the pH near an anode will decrease (due to the produced protons), when a current is supplied.

30 In Figure 1, a suspension of particulate material is provided as anolyte (4.1), and a solution is provided as catholyte (5.1), in the respective compartments of the first cell (1). During electrolysis, the pH in the anolyte will decrease due to the reaction (R2). As the pH decreases, metals bound in the particulate material dissolve and will be released as cations. Due to the charge of the electrodes, the released cations will migrate to the catholyte (5.1). The released cations typically include calcium ions, and/or heavy metals (HM), and/or other cations.

35

In an embodiment of the invention, the heavy metals include Ba, Se, Sb, Mo, Cd, Cr, Cu, Ni, Pb, Zn, Sn, and Hg. In a further embodiment the heavy metals include Cd, Cr, Cu, Pb, Ni and Zn. In a further embodiment of the present invention the heavy metals include metals that upon dissolution form positively charged ions that are capable of migrating into the cathode compartment during the remediation process. Some heavy metals may form positively charged ions and/or negatively charged ions upon dissolution. For example, As, Sb, Cr, and Mo may form negatively charged ions upon dissolution, e.g. AsO_4^{3-} .

10 The type of released cations will depend on the pH, and the complexing affinity of the cations. Figures 3 and 4 show the solubility of Al-, Fe-, and Ca-phosphates as a function of pH. Figure 5 show the solubility of metal hydroxides, such as Al- and Fe-hydroxides.

15 From Figure 3 it is seen that under acidic conditions, Ca-phosphates are the most easily dissolved, and they will dissolve and be released as Ca cations and phosphate ions.

20 The Al- and Fe-phosphates are seen to be less easy to dissolve. However, under alkaline conditions, only Al- and Fe-phosphates are soluble, whereas most Ca-phosphates are insoluble. The solubility as a function of pH of other calcium orthophosphoric compounds are also seen in Figure 4.

25 From Figure 5 it follows that the dissolution of the Al- and Fe-phosphates under alkaline environment results in negative ions of phosphorous (e.g. HPO_4^{2-} , PO_4^{3-}), and the dissolved Al- and Fe-components may form insoluble hydroxides,

30 Under acidic conditions, the cations from calcium phosphates will be released and occur mainly as simple cations (Ca^{2+}). In contrast, the released Al and Fe ions are known to form positively charged Al-P and Fe-P complexes. Examples of such complexes can be $\text{Al}(\text{HPO}_4)^+$, $\text{Fe}(\text{H}_2\text{PO}_4)^+$, $\text{Fe}(\text{H}_2\text{PO}_4)^{2+}$ and $\text{Fe}(\text{HPO}_4)^+$.

Thus, as the electrolysis proceeds, first Ca ions and optionally heavy metals (HM) will be released and migrate into the first catholyte (5). Subsequently, Al-P and Fe-P

complexes are formed, and due to their charge, they will also migrate into the first catholyte (5.1).

5 From the successive migration it follows that the migration of the phosphorus complexes (Al-P and Fe-P) during the electrolysis process may be controlled and avoided by the electrolysis parameters such as the pH, current load and time. In an embodiment of the invention, the electrolysis process of the first cell (1) is controlled such that only calcium ions, and optionally heavy metals, will be released and migrate into the first catholyte (5.1). The embodiment is illustrated in Figure 1.

10

In an embodiment of the invention, the metal ions concentrated in step (e) comprises calcium ions and/or heavy metal ions.

15

Subsequent to the electrolysis in the first electrolysytic cell (1), the treated particulate material, i.e. the anolyte (4.1), is transferred to filtering means (3) as illustrated in Figure 1. From the filtering means, the solid residual and the liquid filtrate is further transferred to the second electrolysytic cell (2). The residual is transferred to the catholyte compartment (7) of the second cell to be comprised in the second catholyte (7.1), and the filtrate is transferred to the anolyte compartment (6) of the second cell to be comprised in the second anolyte (6.1). The residual will comprise the particulate material including the phosphorus bound as Al- and Fe-phosphates, and the filtrate will comprise the released phosphate ions originally bound to Ca.

20

25

When electrolysis in the second electrolysytic cell (2) is carried out, negatively charged species will migrate into the second anolyte (6.1). Furthermore, according to the electrode reaction (R1), the pH in the catholyte compartment will increase during the electrolysis. The increase will result in the dissolution of the Al- and Fe- phosphates, as seen from Figure 3, and thus the release of the negatively charged phosphorous species, which will migrate to the anolyte (6.1). The increased pH could also cause any present calcium to precipitate as Ca-phosphates, as seen from Figures 3 and 4. However, if calcium has been removed in the first electrolysytic cell, Ca-P-precipitates are avoided.

30

35

The sequential process results in a high degree of phosphorus being mobilised from a particulate material, as well as the mobilised phosphorus being made available for

extraction and recovery. In addition any heavy metals may be removed. In an embodiment of the invention, the method is used for combined electro dialytic phosphorus recovery and heavy metal removal.

5 In the first electro dialytic cell, the pH conditions are configured such that phosphorus bound to calcium is mobilised and extracted to a liquid phase. In the second electro dialytic cell, the pH conditions are configured such that phosphorus bound to aluminium and iron is mobilised and extracted to the same liquid phase as the phosphorus originally bound to calcium, by the use of filtration means.

10

The high phosphorus recovery of the invention is obtained by both a high degree of mobilisation of phosphorus compounds, as well as mobilisation into a form that can be extracted. Thus, phosphorus bound to Ca as well as phosphorus bound to Fe and Al can be mobilised and extracted to the same liquid based product.

15

Control of the electro dialytic treatment parameters is essential to obtain a high phosphorus recovery. Furthermore, the treatment parameters will depend on the amount of ash to be treated.

20

In an embodiment of the invention, the first and second currents, of respectively the first and second electro dialytic cell, are below 3 mA/g ash, more preferably below 2 mA/g ash, and most preferably below 1.5 mA/g ash. In a further embodiment, the first and second currents are supplied for between 1.25 to 4.5 h/g ash, more preferably between 1.25 to 2.25 h/g ash.

25

In another embodiment of the invention, the first and second currents are supplied for a time relative to the amount of particulate material, and wherein the time is between 1.25 to 4.5 h/g particulate material, more preferably between 1.25 to 2.25 h/g particulate material.

30

An embodiment of the apparatus illustrated in Figures 1-2 for the sequential electro dialytic extraction of phosphorus from a particulate material in suspension, comprises: a first electro dialytic cell (1) comprising a first anolyte compartment (4) comprising a first anolyte (4.1), and a first catholyte compartment (5) comprising a first catholyte (5.1), wherein the compartments of the first cell (4, 5) are separated by a

35

cation exchange membrane (8), and wherein the first anolyte (4.1) is the particulate material in suspension; a second electrolysytic cell (2) comprising a second anolyte compartment (6) comprising a second anolyte (6.1), and a second catholyte compartment (7) comprising a second catholyte (7.1), wherein the compartments of the second cell (6, 7) are separated by an anion exchange membrane (9); and
5 filtration means (3) in fluid communication with the compartments (4, 6, 7) and configured to filter the first anolyte (4.1), and transfer the residual into the second catholyte compartment (7) to be comprised in the second catholyte (7.1), and transfer the filtrate (3.1) into the second anolyte compartment (6) to be comprised in the second
10 anolyte (6.1).

Larger quantities of phosphorus may be extracted from large quantities of particulate material by repeating the described sequential process any number of times to treat further particulate material. In an embodiment of the invention, the sequential process
15 is repeated one or more times times, to treat further particulate material.

For any of the repetitions, one or more of the electrolytes, or parts thereof, may be recycled. By re-using or recycling the anolytes and/or catholytes, or parts thereof, the operational cost can be reduced, as the required amounts of liquid are reduced, as well
20 as the amount of current to decrease or increase the pH to a certain degree, will be reduced.

For recycling of the fluids, the apparatus comprises circulation means as indicated in Figure 2. Any type of circulations means known to the skilled person may be applied,
25 such as pumps.

In an embodiment of the invention, the apparatus further comprises circulation means for transferring a fluid comprised in one unit (3-7,10) to the same or another unit (3-7,10), such that the apparatus is configured for recycling fluids, and wherein the
30 circulation means optionally are pumps.

In an embodiment of the invention, the apparatus further comprises circulation means for recycling fluids, such as the first catholyte (5.1), second anolyte (6.1), and filtrates (3.1, 10.1). In a further embodiment of the invention, the circulation means are pumps.
35

In an embodiment of the invention, the sequential process is repeated one or more times, and wherein the first catholyte (5.1) is recycled, and/or the first filtrate (3.1) is recycled, and/or the filtrate of the second catholyte (10.1) is recycled, and/or the second anolyte (6.1) is recycled.

5

In a further embodiment of the invention, the sequential process is repeated one or more times, and wherein the first catholyte (5.1) is recycled to be comprised in the first catholyte (5.1), and/or the first filtrate (3.1) is recycled to be comprised in the first anolyte (4.1), and/or the second anolyte (6.1) is recycled to be comprised in the first anolyte (4.1), and/or the second filtrate (10.1) is recycled to be comprised in the second catholyte (7.1).

10

In a further embodiment of the invention, the sequential process is repeated on a further batch of particulate material (i.e. not treated previously), and/or on the particulate material of step (j) to subject the treated material to a second cycle, thereby extracting any phosphorus that have not been recovered from the first cycle.

15

In an embodiment of the invention, the particulate material provided in step (b) is a further batch of particulate material, and step (c)-(j) is repeated thereby defining a second cycle, and optionally wherein the liquid provided in repeated step (c) is recycled first filtrate (3.1), and/or the filtrate of the second catholyte (10.1), and/or the second anolyte (6.1) from the first cycle, and optionally wherein the electrolyte solution of repeated step (d) is the first catholyte from the first cycle.

20

In a further embodiment of the invention, the particulate material provided in step (b) is the particulate material of step (j) or a further batch of particulate material, and step (c)-(j) is repeated thereby defining a second cycle,, and optionally wherein the liquid provided in repeated step (c) is recycled first filtrate (3.1), and/or the filtrate of the second catholyte (10.1), and/or the second anolyte (6.1) from the first cycle, and optionally wherein the electrolyte solution of repeated step (d) is the first catholyte from the first cycle.

25

30

First electro dialytic cell

The anolyte (4.1) of the first electro dialytic cell (the first anolyte) may comprise a particulate material comprising heavy metals and phosphorus or phosphorous

35

compounds, from which the phosphorus is extracted to be recovered, and optionally also the heavy metals are extracted and removed.

5 Particulate material from waste products are known to comprise significant amounts of heavy metals and phosphorus. In an embodiment of the invention, the particulate material of the first anolyte (4.1) is selected from the group consisting of ash, ash from the thermal treatment of biomass, manure ash, sewage sludge ash, incinerated sewage sludge ash, gasified sewage sludge ash, chemically precipitated sewage sludge, biologically precipitated sewage sludge, or a combination thereof.

10

In another embodiment of the invention, the particulate material of the first anolyte (4.1) comprises phosphorous compounds, wherein the phosphorus is chemically bonded to calcium (Ca), and/or aluminum (Al), and/or iron (Fe).

15

In another embodiment of the invention, the particulate material of the first anolyte (4.1) comprises above 0.5 wt% P bonded to Ca, and/or Al, and/or Fe, more preferably above 1 wt% or 1.5 wt%, and most preferably above 2 wt% or 2.5 wt%.

20

For faster and more homogeneous extraction of the phosphorus and/or heavy metals, the particulate material is suspended in a liquid. In an embodiment of the invention, the particulate material of the first anolyte (4.1) is suspended in a liquid selected from the group consisting of distilled water, tap water, recycled second anolyte (6.1) and recycled filtrate (3.1), diluted acid, such as H_3PO_4 , and any combination thereof.

25

The diluted acid may be phosphoric acid (H_3PO_4), or any other acid.

30

The recycling of the second anolyte (6.1) or the first filtrate (3.1) in a repeated process are illustrated in Figure 2. By re-using or recycling the second anolyte (6.1) or first filtrate (3.1) as the liquid comprised in the first anolyte (4.1), the operational cost of the apparatus can be limited. The required amounts of liquid and current, to provide acidic conditions, will be reduced when the second anolyte is recycled.

35

The extraction process may also depend on the solid load of particulate material in the suspension. The solid load may be indicated by the liquid/solid ratio (L/S) of the suspended particulate material.

In an embodiment of the invention, the liquid/solid ratio (L/S) of the suspended particulate material in the first anolyte (4.1) is above 30, more preferably equal to or above 20, and most preferably equal to or above 10, or equal to or above 2.

5

A key parameter determining the type and amounts of released cations and anions from the particulate material is the pH. In an embodiment of the invention, the pH of the first anolyte (4.1) is controlled by a first electro-dialytic current, and wherein the pH decreases during the first electro-dialytic treatment. In a further embodiment of the invention, the pH of the first anolyte (4.1) is below 4, more preferably below 2.5, and most preferably below 2. In a further embodiment of the invention, the pH is further controlled by the type of liquid added to the first anolyte (4.1), such as diluted acid. In a further embodiment, the apparatus is configured such that the pH of the first anolyte (4.1) is controlled by a first electro-dialytic current, and configured such that the pH decreases during the first electro-dialytic treatment, and/or wherein the pH of the first anolyte (4.1) is below 4, more preferably below 2.5, and most preferably below 2.

10

15

The catholyte (5.1) of the first electro-dialytic cell (the first catholyte) may be any electrolyte facilitating the electro-dialytic process of the first cell.

20

In an embodiment of the invention, the first catholyte (5.1) is an electrolyte solution. In a further embodiment of the invention, the first catholyte (5.1) is selected from the group consisting of solutions of sodium nitrate (NaNO_3), solutions of sodium chloride, solutions of nitric acid, solutions of hydrochloric acid, distilled water, tap water, and recycled first catholyte (5.1).

25

The recycling of the first catholyte (5.1) as first catholyte (5.1) in a repeated process is illustrated in Figure 2. By re-using or recycling, the operational cost of the apparatus can be limited.

30

The first electro-dialytic cell (1) comprise a cation exchange membrane (8) as shown in Figures 1-2. The cation exchange membrane is a semipermeable membrane, which allows the passage of the positive charges (cations), while preventing the passage of negative charges (anions). The released cations (calcium and optionally heavy metals)

will migrate through the cation exchange membrane (8) and into the catholyte (5.1) in the cathode compartment (5), due to the polarity of the electrodes.

Stirring means

5 To avoid sedimentation of the suspended particulate material, and for efficient operation of the electro dialytic processes in the electro dialytic cells, it is advantageous that the catholytes and/or anolytes in the compartments are stirred. In an embodiment of the invention, one or more of the compartments (4, 5, 6, 7) further comprises stirring means. In a further embodiment, the first anolyte compartment (4) and/or the second
10 catholyte compartment (7) comprises stirring means.

Stirring means suitable for electro dialytic cells are known to the skilled person. In an embodiment of the invention, the stirring means are selected from the group consisting of overhead stirrer, magnetic stirrer, and stirring by gas bubbling, such as air or CO₂
15 bubbling.

Heating means

To control or accelerate the extraction process further, it may be advantageous that the electrolytes (i.e. anolytes and catholytes) are heated. In an embodiment of the
20 invention, one or more of the compartments (4, 5, 6, 7) further comprises heating means. In a further embodiment of the invention, the temperature of one or more of the anolytes and/or catholytes (4.1, 5.1, 6.1, 7.1) is above room temperature. In a further embodiment of the invention, the temperature of the one or more electrolyte(s) is above 30 °C, more preferably above 40 °C or 50 °C.

25 The apparatus of the invention may be used in a wastewater treatment plant, where waste heat in the form of heat streams are known to be present. In an embodiment of the invention, the heating means are driven by the waste heat streams from a wastewater treatment plant. The conversion of waste heat for use as heating means for
30 electrolytes in an electro dialytic cell are known to a person skilled in the art.

Filtration means (3,10)

Filtration is a mechanical operation for the separation of solids from fluids. The operation may be carried out using a filter or a membrane, which allows the fluid to
35 pass through or flow through, and prevents the solids from passing through. The liquid

that passes through is called the filtrate, and the resident particles are called the residual.

5 Filtration means may be a filter with a defined mesh size, where the mesh size describes the size of the openings. Filtration through multiple filters may be carried out, and the filtration may further be assisted by use of vacuum, i.e. vacuum filters. Figure 2 illustrates an embodiment of the invention, where the filtration means (3) comprises two filtration means, a filter and a vacuum filter.

10 In an embodiment of the invention, the filtration means is selected from the group of filter paper, vacuum filters, and a combination thereof.

In a further embodiment of the invention, the filter mesh size is equal to or below 50 μm , more preferably equal to or below 45 μm , and most preferably equal to or below 40 μm , and optionally combined with a vacuum filter. In a further embodiment of the
15 invention, the vacuum filter has a filter mesh size equal to or below 10 μm , more preferably equal to or below 1 μm , and most preferably equal to or below 0.45 μm .

Second electrolysytic cell

20 The anolyte (6.1) of the second electrolysytic cell (the second anolyte) is the filtrate (3.1) from the first filtration means (3), and corresponds to the produced liquid of the first anolyte, as illustrated in Figures 1-2. The second anolyte may be further recycled as a liquid for the first anolyte (4.1) as illustrated in Figure 2.

25 The catholyte (7.1) of the second electrolysytic cell (the second catholyte) comprises the residual from the filtration means, which corresponds to the particulate material of the first anolyte, as illustrated in Figures 1-2. The catholyte (7.1) may further comprise additional liquid such that the residual becomes suspended in the liquid to further facilitate the electrolysytic extraction process. In an embodiment of the invention, the second catholyte (7.1) comprises the residual from the first filtration means and a
30 further liquid phase. In a further embodiment of the invention, the further liquid phase is selected from the group consisting of water, distilled water, tap water, sodium hydroxide (NaOH), recycled filtrate from the second filtration means (10.1), and any combination thereof.

During the electro dialytic operation in the second electro dialytic cell, the pH of the second catholyte (7.1) increases thereby facilitating the dissolution Al- and Fe-phosphates, and thus release of phosphate ions. The pH is therefore a key parameter for controlling the extration process of phosphorus. It further follows from Figure 5 that the dissolution of the Al- and Fe-phosphates under alkaline environment results in negative ions of phosphorous (e.g. HPO_4^{2-} , PO_4^{3-}), and the dissolved Al- and Fe-components will form insoluble hydroxides.

In an embodiment of the invention, the pH of the second catholyte (7.1) is controlled by a second electro dialytic current, and wherein the pH increases during the second electro dialytic treatment. In a further embodiment, the apparatus is configured such that the pH of the second catholyte (7.1) is controlled by a second electro dialytic current, and configured such that the pH increases during the second electro dialytic treatment.

The electro dialytic treated second catholyte (7.1) may also be recycled as illustrated in Figure 2. The second catholyte may be transferred to a second filtration means (10), where it is filtered into a second residual and a second filtrate. In an embodiment of the invention, the apparatus further comprises second filtration means (10) in fluid communication with the second catholyte compartment (7) configured to filter the second catholyte (7.1) into a second residual and a second filtrate (10.1). In a further embodiment of the invention, the second filtrate is recycled as the further liquid in the second catholyte (7.1) as illustrated in Figure 2. In a further embodiment, the filtration means is a filter with a mesh size of equal to or below $50\ \mu\text{m}$, more preferably equal to or below $45\ \mu\text{m}$, and most preferably equal to or below $40\ \mu\text{m}$, and optionally combined with a vacuum filter.

The second residual from the second filtration means (10) may be deposited as waste. In cases where the heavy metals and phosphorus are removed, the waste may be deposited without environmental concerns. Furthermore, the clean waste may be recycled as raw material for rockwool, concrete or brick production.

The second electro dialytic cell (2) comprises an anion exchange membrane (9) as shown in Figures 1-2. The anion exchange membrane is a semipermeable membrane, which allows the passage of the negative charges (anions), while preventing the

passage of positive charges (cations). The anions will migrate through the anion exchange membrane and into the anolyte in the anode compartment (6), due to the polarity of the electrodes.

5 **Examples**

Example 1: High P recovery (70%)

10 Ash resulting of thermally treating sludge from Randers Centralrenseanlæg by means of Pyroneer technology (low-T gasification). The P of the sludge was captured 50% biologically and 50% chemically (using Fe and Al salts). The ash initially contained around 2.7% P, 1.0% Al, 3.1% Ca and 5.5% Fe.

The membrane of the cell was Ionics (GE): ANION,AR204SZRA, and CATION,CR67.

15 *First electro dialytic cell*

35 g of ash was mixed with 350 mL of distilled water in the first ED cell in the anolyte. 500 mL of the electrolyte solution (0.01 M NaNO₃, pH=2) was placed in the catholyte, and a 50 mA current was applied until the anolyte reached a pH of 1.7, (52.5 hours). The decrease of pH in the anolyte involved the dissolution of Ca, P and heavy metals.

20

Filtration means

At the end of this experiment, the anolyte and the bulk SSA (sewage sludge ash) were separated through a filtration at atmospheric pressure with a filter paper of 40 µm. In order to maximize the effective separation of P, 200 mL of distilled water was flushed through the SSA in the filter, resulting in a filtrate with a total volume of 470 mL. The total P extracted from the ash was around 27.3%, whereas 23.7% of P (0.24 g) was mobilized to the filtrate, and thus recovered. The filter paper with the SSA was dried overnight. After this treatment, the resulting ash weighted 31.4 g and had a content of around 2.3% of P.

30

Second electro dialytic cell

25.1 g of the ash resulting from the first ED treatment was mixed with 300 mL of distilled water in the catholyte of the second ED cell with 8 mL of NaOH 1 M. The 470 mL of the filtrate liquid from the first ED cell was vacuum filtrated through a filter of 0.45 µm and used as electrolyte solution in the anolyte of this second ED cell. A current was applied at 50 mA for 3 days. The pH of the catholyte at the end of the experiment

35

was 12.2. Surprisingly around 63.4% of the P content was mobilized to the anolyte allowing an overall P-recovery of around 70%:

$$\text{recovered P} = \overbrace{23.7\%}^{\text{1st ED recovery}} + \left(\overbrace{100\% - 27.3\%}^{\substack{\text{P remaining after the first ED} \\ \text{1st ED extraction}}} \right) \times \left(\overbrace{63.4\%}^{\text{2nd ED recovery}} \right) = 69.8\%$$

5 The total amount of P recovered in this example was 0.6 g. This was obtained with the electrical current applied for a total of 124.5 hours (i.e. 52.2 hours in the first cell, and 3 days in the second cell). This is considerably higher than what was extracted in the single two-compartment ED cell setup (i.e. not a sequential setup) disclosed in [1] for a similar period (cf. Example 4) . The final ash weighted 22.8 g and the P content was
10 around a 0.8%. The content of the anolyte solution at the end of the experiment was as follows:

P: 1.3 g/L Fe: 0.03 g/L Al: 0.03 g/L As: 0.15 mg/L, Cd<0.02 mg/L,
Cr<0.02 mg/L, Cu: 0.2 mg/L, Ni:0.02 mg/L, Pb: 0.06 mg/L, Zn: 1 mg/L

This corresponds to a MER value of 0.04.

15

The consumption of chemicals was:

- For the pH regulation in first cell:

$$\frac{13 \text{ mL } HNO_3 \text{ 5 M}}{\left(35 \text{ g ash} \cdot \frac{2.7 \text{ g P} \cdot 23.7\% \text{ recovered P}}{100 \text{ g ash}} + 25.1 \text{ g ash} \cdot \frac{2.3 \text{ g P} \cdot 63.4\% \text{ recovered P}}{100 \text{ g ash}} \right) \cdot \frac{1 \text{ mole P}}{31 \text{ g P}}}$$

$$= 3.42 \frac{\text{mole } HNO_3}{\text{mole P}}$$

20

- For the NaOH used in the second cell:

$$\frac{8 \text{ mL } NaOH \text{ 1 M}}{\left(35 \text{ g ash} \cdot \frac{2.7 \text{ g P} \cdot 23.7\% \text{ recovered P}}{100 \text{ g ash}} + 25.1 \text{ g ash} \cdot \frac{2.3 \text{ g P} \cdot 63.4\% \text{ recovered P}}{100 \text{ g ash}} \right) \cdot \frac{1 \text{ mole P}}{31 \text{ g P}}}$$

$$= 0.42 \frac{\text{mole } NaOH}{\text{mole P}}$$

Example 2: Electrodialytic treatment time

The experiment from Example 1 was repeated, i.e. treating an ash from the same origin as Example 1 and with a similar composition (around 3.5% P, 1.2% Al, 4.1% Ca and 6.6% Fe), but where the electrodialytic (ED) treatment time of the first electrodialytic cell was prolonged. The first ED step was continued until the pH was 1.5 (5 days and 6
5 hours approximately).

This resulted in extraction of 29.1% of P, and mobilization of around 23.1% of P into the first anolyte. This corresponded to 0.29 g P recovered, which is not significantly higher than the 0.24 g recovered in the first step of Example 1.

Thus, significant longer electrodialytic treatment time did not improve the total
10 phosphorus recovery significantly.

Example 3: Solid load

The example is carried out as Example 1, but where the liquid/solid ratio (L/S) of the
15 suspension to be treated is increased from L/S=10, to L/S=20. Thus, in the latter case, 350 mL of distilled water is mixed with 17.5 g of ash.

Example 4: P recovery using the non-sequential setup disclosed in [1]

20 Starting material, i.e. treated ash from the same origin (i.e. sewage sludge ashes from low-T gasification) as for Example 1, was used, having a similar composition (around 3.5% P, 1.2% Al, 4.1% Ca and 6.6% Fe).

The starting material was exposed to P recovery as described in Example 1, but where
25 the recovery was stopped after the first electrolytic cell. Thus, the setup was not sequential as described in Example 1, but corresponds to first electrolytic cell, which is identical to the setup disclosed in [1].

The electrodialytic treatment was continued until the pH was 1.5. The current was
30 applied for 125 hours, which is similar to the total remediation time of Example 1 (124.5 hours).

During the treatment, heavy metals are dissolved into positive ions, which are
35 separated from the sludge by migration into the catholyte. Phosphorous from the particulate material may also be dissolved in the anolyte during the process.

Phosphorus is mainly dissolved into ions with negative charge, which will stay mobilised in the anolyte. However, a minor part (ca. 6.5% as reported in [1]) of the phosphorus may be dissolved and form positive charged complexes, which will migrate into the catholyte.

5

This resulted in extraction of 29.1% of P, and mobilization of around 23.1% of P into the anolyte. This corresponded to 0.29 g P recovered, which is significantly lower than the 70% recovery in Example 1.

10 The lower P recovery for the non-sequential setup is ascribed to the presence of Al- and Fe- phosphates which are not fully dissolved and mobilised in the acidic environment.

15 Thus, for particulate material comprising phosphorus bound to alkaline soluble compounds, a high recovery of phosphorus is not obtained with the non-sequential setup. High P recovery with the non-sequential setup can only be obtained for particulate material with low contents of only alkaline soluble compounds, such as ash from sewage sludge with a low content of Al- and Fe-phosphates.

20 Thus, significant longer electrolytic treatment time with the setup according to [1] resulted in much lower phosphorus recovery of the treated material.

Moreover, the proportions of Al and Fe to P in the anolyte were considerably higher than in Example 1, and consequently MER was higher (0.129), making it a product not
25 suitable for the production of common fertilizers like DAP.

Example 5: Electrodialytic treatment of particulate material comprising phosphorus bound to Ca

30 The starting particulate material is incineration sewage sludge ashes where P is precipitated with $\text{Ca}(\text{OH})_2$. The ash further contains Al due to the use of Al salts in the flocculation step at the wastewater treatment plant, or the zeolites present in the wastewater. The ash contains 5% Al, 10% Ca and 5% P, and P is mainly bound to Ca in the ash (i.e. the original ash state).

35

Non-sequential electrodialytic treatment according to [1] may result in low P recovery, The Ca-P compounds are dissolved in the non-sequential setup, however the released P is likely to form Al-P compounds, which are less soluble than Ca-P bindings in acidic pH as seen from Figure 3. All dissolved P from the Ca-phosphates may be
5 reprecipitated as Al-phosphates, which are not recovered using the non-sequential electrodialytic treatment. Thus, using the non-sequential method results in lower P recovery.

10 The sequential electrodialytic treatment according to the present invention may result in a higher P recovery, since the Al-phosphates formed may be dissolved and recovered in the second electrodialytic cell under alkaline conditions.

Example 6: Electrodialytic treatment of particulate material comprising phosphorus bound to Ca and Al

15

The starting particulate material is incineration sewage sludge ashes where P is precipitated using 50% with $\text{Ca}(\text{OH})_2$ and 50% with AlCl_3 . The ash further contains Al due to the use of Al salts in the flocculation step at the wastewater treatment plant, or the zeolites present in the wastewater. The ash contains 5% Al, 5% Ca and 5% P, and
20 P is essentially 50% bound to Ca and 50% to Al in the ash.

Non-sequential electrodialytic treatment according to [1] may result in low P recovery. The Ca-P bindings are dissolved, however, in this treatment new Al-P bindings could be formed from dissolved Al and P, which are less soluble than Ca-P bindings in acidic
25 pH (cf. Figure 3). In the worst case scenario, all dissolved P from Ca-phosphates would be re-precipitated as Al-phosphates, which are not recovered using the non-sequential electrodialytic treatment.

30 The sequential electrodialytic treatment according to the present invention may result in a higher P recovery, since the Al-phosphates formed may be dissolved and recovered in the second electrodialytic cell under alkaline conditions.

Example 7: Electrodialytic treatment of particulate material comprising phosphorus bound to Ca and Fe(III)

35

The starting material is gasification sewage sludge ashes where P is precipitated 50% with $\text{Ca}(\text{OH})_2$ and 50% with FeCl_3 . The ash further contains Fe(III) due to the use of Fe(III) salts in the flocculation step at the wastewater treatment plant. The ash contains 5% Ca, 10% Fe and 5% P, and the P is essentially 50% bound to Ca and 50% to Fe(III) in the ash.

Non-sequential electrodialytic treatment according to [1] may result in low P recovery. The Ca-P bindings are dissolved, however, in this treatment new Fe(III)-P bindings could be formed from dissolved P and Fe(III), which are less soluble than Ca-P bindings in acidic pH (cf. Fig. 3). In the worst case scenario, all dissolved P from Ca-phosphates would be re-precipitated as Fe(III)-phosphates, which are not recovered using the non-sequential electrodialytic treatment.

The sequential electrodialytic treatment according to the present invention may result in a higher P recovery, since the Fe(III)-phosphates formed may be dissolved and recovered in the second electrodialytic cell under alkaline conditions.

Example 8: Electrodialytic treatment of particulate material comprising phosphorus bound to Al

The starting material is incineration sewage sludge ashes where P is precipitated with AlCl_3 . The ash further contains Ca due to the use of lime as stabilizer at the wastewater treatment plant. The ash contains 5% Al, 10% Ca and 5% P, and P is essentially bound to Al in the ash.

Non-sequential electrodialytic treatment according to [1] may result in low P recovery. The Al-P bindings may only be dissolved to a limited degree under acidic conditions. Thus, the P is not recovered using the non-sequential electrodialytic treatment.

The sequential electrodialytic treatment according to the present invention may result in a higher P recovery. Any P compounds dissolved, may form Ca-P compounds. The Ca-phosphates formed may be dissolved and recovered in the first electrodialytic cell under acidic conditions, and the Al-P compounds may be dissolved and recovered in the second electrodialytic cell under alkaline conditions.

35

Example 9: Electrodialytic treatment of particulate material comprising phosphorus bound to Fe(III)

5 The starting material is gasification sewage sludge ashes where P is precipitated with FeCl₃. The ash further contains Ca due to the use of lime as stabilizer at the wastewater treatment plant. The ash contains 10% Ca, 10% Fe and 5% P, and P is essentially bound to Fe(III) in the ash.

10 Non-sequential electrodialytic treatment according to [1] may result in low P recovery. The Fe-P bindings may only be dissolved to a limited degree under acidic conditions. Thus, the P is not recovered using the non-sequential electrodialytic treatment.

15 The sequential electrodialytic treatment according to the present invention may result in a higher P recovery. Any P compounds dissolved, may form Ca-P compounds. The Ca-phosphates formed may be dissolved and recovered in the first electrodialytic cell under acidic conditions, and the Fe-P compounds may be dissolved and recovered in the second electrodialytic cell under alkaline conditions.

Items

20 The invention can be further described by the items listed below.

Item 1

An apparatus for electrodialytic extraction of phosphorus from a particulate material in suspension, comprising:

- 25
- a first electrodialytic cell (1) comprising
 - a first anolyte compartment (4) comprising a first anolyte (4.1), and
 - a first catholyte compartment (5) comprising a first catholyte (5.1), wherein the compartments of the first cell (4, 5) are separated by a cation exchange membrane (8), and wherein the first anolyte (4.1) is the
- 30
- a second electrodialytic cell (2) comprising
 - a second anolyte compartment (6) comprising a second anolyte (6.1), and
 - a second catholyte compartment (7) comprising a second catholyte
- 35
- (7.1),

wherein the compartments of the second cell (6, 7) are separated by an anion exchange membrane (9); and
filtration means (3) in fluid communication with the compartments (4, 6, 7) and configured to filter the first anolyte (4.1), and transfer the residual into the second catholyte compartment (7) to be comprised in the second catholyte (7.1), and transfer the filtrate (3.1) into the second anolyte compartment (6) to be comprised in the second anolyte (6.1).

Item 1a

10 An apparatus for electrodiolytic extraction of phosphorus from a particulate material comprising acidic and/or alkaline soluble phosphorus compounds, in suspension, comprising:

a first electrodiolytic cell (1) comprising

15 a first anolyte compartment (4) comprising a first anolyte (4.1), and a first catholyte compartment (5) comprising a first catholyte (5.1), wherein the compartments of the first cell (4, 5) are separated by a cation exchange membrane (8), wherein the first anolyte (4.1) is the particulate material in suspension, the first electrodiolytic cell configured for exposing the particulate
20 material to acidic conditions;

a second electrodiolytic cell (2) comprising

25 a second anolyte compartment (6) comprising a second anolyte (6.1), and a second catholyte compartment (7) comprising a second catholyte (7.1), wherein the compartments of the second cell (6, 7) are separated by an anion exchange membrane (9), the second electrodiolytic cell configured for exposing the particulate
30 material to alkaline conditions; and

filtration means (3) in fluid communication with the first and second electrodiolytic cells (1, 2), and configured to filter the first anolyte (4.1) and transfer the residual into the second catholyte compartment (7) to be comprised in the second catholyte (7.1) and transfer the filtrate (3.1) into the second anolyte compartment (6) to be comprised in the second anolyte (6.1).

35

Item 2

The apparatus according to item 1 or 1A, further comprising circulation means for recycling fluids, such as the first catholyte (5.1), second anolyte (6.1), and filtrates (3.1, 10.1).

5

Item 2A

The apparatus according to items 1 or 1A, further comprising circulation means for transferring a fluid comprised in one unit (3-7,10) to the same or another unit (3-7,10), such that the apparatus is configured for recycling fluids, and wherein the circulation means optionally are pumps.

10

Item 3

The apparatus according to item 2, wherein the circulation means are pumps.

15

Item 4

The apparatus according to any of the preceding items, wherein the particulate material of the first anolyte (4.1) is selected from the group consisting of ash, ash from the thermal treatment of biomass, manure ash, sewage sludge ash, incinerated sewage sludge ash, gasified sewage sludge ash, chemically precipitated sewage sludge, biologically precipitated sewage sludge, or a combination thereof.

20

Item 5

The apparatus according to any of the preceding items, wherein the particulate material of the first anolyte (4.1) comprises phosphorous compounds, wherein the phosphorus is chemically bonded to calcium (Ca), and/or aluminium (Al), and/or iron (Fe).

25

Item 6

The apparatus according to any of the preceding items, wherein the particulate material of the first anolyte (4.1) comprises above 0.5 wt% P bonded to Ca, and/or Al, and/or Fe, more preferably above 1 wt% or 1.5 wt%, and most preferably above 2 wt% or 2.5 wt%.

30

Item 7

The apparatus according to any of the preceding items, wherein the particulate material of the first anolyte (4.1) is suspended in a liquid selected from the group consisting of

35

distilled water, tap water, recycled second anolyte (6.1) and recycled filtrate (3.1), diluted acid, and any combination thereof.

Item 8

5 The apparatus according to any of the preceding items, wherein the liquid/solid ratio (L/S) of the suspended particulate material in the first anolyte (4.1) is above 30, more preferably equal to or above 20, and most preferably equal to or above 10, or equal to or above 2.

10 Item 9

The apparatus according to any of the preceding items, wherein the pH of the first anolyte (4.1) is controlled by a first electrolysytic current, and wherein the pH decreases during the first electrolysytic treatment.

15 Item 9A

The apparatus according to any of the preceding items, configured such that the pH of the first anolyte (4.1) is controlled by a first electrolysytic current, and configured such that the pH decreases during the first electrolysytic treatment, and/or wherein the pH of the first anolyte (4.1) is below 4, more preferably below 2.5, and most preferably
20 below 2.

Item 10

The apparatus according to any of the preceding items, wherein the pH of the first anolyte (4.1) is below 4, more preferably below 2.5, and most preferably below 2.
25

Item 11

The apparatus according to any of the preceding items, wherein the first catholyte (5.1) is an electrolyte solution.

30 Item 12

The apparatus according to any of the preceding items, wherein the first catholyte (5.1) is selected from the group consisting of solutions of sodium nitrate, solutions of nitric acid, distilled water, tap water, and recycled first catholyte (5.1).

35 Item 12A

The apparatus according to any of the preceding items, wherein the first catholyte (5.1) is an electrolyte solution, preferably selected from the group consisting of solutions of sodium nitrate, solutions of sodium chloride, solutions of nitric acid, solutions of hydrochloric acid, distilled water, tap water, and recycled first catholyte (5.1).

5

Item 13

The apparatus according to any of the preceding items, wherein one or more of the compartments (4, 5, 6, 7) further comprises stirring means.

10

Item 14

The apparatus according to item 13, wherein the stirring means are selected from the group consisting of overhead stirrer, magnetic stirrer and stirring by gas bubbling.

Item 15

15

The apparatus according to any of the preceding items, wherein one or more of the compartments (4, 5, 6, 7) further comprises heating means.

Item 16

20

The apparatus according item 15, wherein the temperature of one or more of the analytes and/or catholytes (4.1, 5.1, 6.1, 7.1) is above room temperature.

Item 17

The apparatus according to any of items 15-16, wherein the temperature is above 30 °C, more preferably above 40 °C or 50 °C.

25

Item 18

The apparatus according to any of the preceding items, wherein the filtration means is selected from the group of filter paper, vacuum filters, and any combination thereof.

30

Item 19

The apparatus according to item 18, wherein the filter mesh size is equal to or below 50 μm , more preferably equal to or below 45 μm , and most preferably equal to or below 40 μm , and optionally combined with a vacuum filter.

35

Item 20

The apparatus according to any of items 18-19, wherein the vacuum filter has a filter mesh size equal to or below 10 μm , more preferably equal to or below 1 μm , and most preferably equal to or below 0.45 μm .

5 Item 21

The apparatus according to any of the preceding items, wherein the second catholyte (7.1) comprises the residual from the filtration means and a further liquid phase.

Item 22

- 10 The apparatus according to item 21, wherein the further liquid phase is selected from the group consisting of water, distilled water, tap water, sodium hydroxide (NaOH), recycled filtrate from the second filtration means (10.1), and any combination thereof.

Item 23

- 15 The apparatus according to any of the preceding items, wherein the pH of the second catholyte (7.1) is controlled by a second electrolysytic current, and wherein the pH increases during the second electrolysytic treatment.

Item 23A

- 20 The apparatus according to any of the preceding items, configured such that the pH of the second catholyte (7.1) is controlled by a second electrolysytic current, and configured such that the pH increases during the second electrolysytic treatment.

Item 24

- 25 The apparatus according to any of the preceding items, further comprising second filtration means (10) in fluid communication with the second catholyte compartment (7) configured to filter the second catholyte (7.1) into a second residual and a second filtrate (10.1).

30 Item 25

The apparatus according to item 24, wherein the second filtrate is recycled as the further liquid in the second catholyte (7.1) according to items 21-22.

Item 26

A method for electro dialytic phosphorus recovery, comprising:

- (a) providing a first electro dialytic cell (1), comprising a first anolyte compartment (4) and a first catholyte compartment (5), separated by a cation exchange membrane (8);
- (b) providing a particulate material comprising phosphorus;
- 5 (c) mixing the particulate material with a liquid and use it as an anolyte for the first cell (4.1);
- (d) providing an electrolyte solution and use it as a catholyte (5.1) for the first cell;
- (e) applying a first current to the first cell (1);
- whereby metal ions are concentrated in the catholyte (5.1);
- 10 (f) providing a second electro dialytic cell, comprising a second anolyte compartment (6) and a second catholyte compartment (7), separated by an anion exchange membrane (9);
- (g) transferring the treated anolyte (4.1) from the first cell (1) by filtration means such that the treated anolyte is filtered into a residual and a filtrate (3.1);
- 15 (h) transferring the liquid filtrate (3.1) into the second anolyte compartment (6) thereby forming a second anolyte (6.1);
- (i) mixing the residual with water, and transferring the mixture into the second cathode compartment (7) thereby forming a second catholyte (7.1);
- (j) applying a second current to the second cell (2);
- 20 whereby phosphorus and phosphorous compounds are concentrated in the second anolyte (6.1).

Item 26A

A method for electro dialytic phosphorus recovery, comprising:

- 25 (a) providing a first electro dialytic cell (1), comprising a first anolyte compartment (4) and a first catholyte compartment (5), separated by a cation exchange membrane (8);
- (b) providing a particulate material comprising acidic and/or alkaline soluble phosphorus compounds;
- (c) mixing the particulate material with a liquid and use it as an anolyte for the first cell
- 30 (4.1);
- (d) providing an electrolyte solution and use it as a catholyte (5.1) for the first cell;
- (e) applying a first current to the first cell (1) thereby exposing the particulate material to acidic conditions,
- whereby metal ions are concentrated in the catholyte (5.1);
- 35 (f) providing a second electro dialytic cell, comprising a second anolyte compartment (6)

and a second catholyte compartment (7), separated by an anion exchange membrane (9);

(g) transferring the treated anolyte (4.1) from the first cell (1) to filtration means such that the treated anolyte is filtered into a residual and a filtrate ;

5 (h) transferring the liquid filtrate into the second anolyte compartment (6) thereby forming a second anolyte (6.1);

(i) mixing the residual with water, and transferring the mixture into the second cathode compartment (7) thereby forming a second catholyte (7.1);

10 (j) applying a second current to the second cell (2) thereby exposing the particulate material to alkaline conditions, whereby phosphorus and phosphorous compounds are concentrated in the second anolyte (6.1).

Item 27

15 The method according to items 26 or 26, wherein the metal ions concentrated in in step (e) comprises calcium ions and/or heavy metal ions.

Item 28

20 The method according to any of items 26-27, wherein the first and second currents relative to the amount of particulate material are below 3 mA/g particulate material, more preferably below 2 mA/g particulate material, and most preferably below 1.5 mA/g particulate material.

Item 29

25 The method according to any of items 26-28, wherein the first and second currents are supplied for a time relative to the amount of particulate material, and wherein the time is between 1.25 to 4.5 h/g particulate material, more preferably between 1.25 to 2.25 h/g particulate material.

Item 30

30 The method according to any of items 26-29, wherein step (a)-(j) is repeated one or more times, and wherein the first catholyte (5.1) is recycled, and/or the first filtrate (3.1) is recycled, and/or the filtrate of the second catholyte (10.1) is recycled, and/or the second anolyte (6.1) is recycled.

35

Item 30A

The method according to any of items 26-29, wherein the particulate material provided in step (b) is a further batch of particulate material, and step (c)-(j) is repeated thereby defining a second cycle,, and optionally wherein the liquid provided in repeated step (c) is recycled first filtrate (3.1), and/or the filtrate of the second catholyte (10.1), and/or the second anolyte (6.1) from the first cycle, and optionally wherein the electrolyte solution of repeated step (d) is the first catholyte from the first cycle.

Item 31

Use of the apparatus according to any of items 1-25 for wastewater treatment, and/or treatment of particulate material rich in phosphorus.

Item 32

Use of the methods according to any of items 26-30 for wastewater treatment, and/or treatment of particulate material rich in phosphorus.

References

- [1] WO 2015/032903.
- [2] B. Ebbers et al., Abstract no. O131, 13th Symp. EREM, 7th-10th September 2014, Malaga, Spain.
- [3] W. Stumm and J. J. Morgan, Aquatic chemistry : Chemical equilibria and rates in natural waters: Wiley, 1996.
- [4] K. Kuroda and M. Okido, "Hydroxyapatite Coating of Titanium Implants Using Hydroprocessing and Evaluation of Their Osteoconductivity", Bioinorganic Chemistry and Applications v.2012 (2012).
- [5] C. Noubactep, "Relevant reducing agents in remediation Fe⁰/H₂O systems", Clean-Soil Air Water 41(5) (2013) p. 493-502.

Claims

- 5 1. An apparatus for electro dialytic extraction of phosphorus from a particulate material comprising acidic and/or alkaline soluble phosphorus compounds, in suspension, comprising:
- 10 - a first electro dialytic cell (1) comprising
 - a first anolyte compartment (4) comprising a first anolyte (4.1), and
 - a first catholyte compartment (5) comprising a first catholyte (5.1), wherein the compartments of the first cell (4, 5) are separated by a cation exchange membrane (8), wherein the first anolyte (4.1) is the particulate material in suspension, the first electro dialytic cell configured for exposing the particulate material to acidic conditions;
 - 15 - a second electro dialytic cell (2) comprising
 - a second anolyte compartment (6) comprising a second anolyte (6.1), and
 - a second catholyte compartment (7) comprising a second catholyte (7.1), wherein the compartments of the second cell (6, 7) are separated by an anion exchange membrane (9), the second electro dialytic cell configured for exposing the particulate material to alkaline conditions; and
 - 20 - filtration means (3) in fluid communication with the first and second electro dialytic cells (1, 2), and configured to filter the first anolyte (4.1) and transfer the residual into the second catholyte compartment (7) to be comprised in the second catholyte (7.1) and transfer the filtrate (3.1) into the second anolyte compartment (6) to be comprised in the second anolyte (6.1).
- 25
- 30 2. The apparatus according to claim 1, further comprising circulation means for transferring a fluid comprised in one unit (3-7,10) to the same or another unit (3-7,10), such that the apparatus is configured for recycling fluids.
- 35 3. The apparatus according to any of the preceding claims, wherein the particulate material of the first anolyte (4.1) is selected from the group consisting of ash,

ash from the thermal treatment of biomass, manure ash, sewage sludge ash, incinerated sewage sludge ash, gasified sewage sludge ash, chemically precipitated sewage sludge, biologically precipitated sewage sludge, or a combination thereof.

5

4. The apparatus according to any of the preceding claims, wherein the particulate material of the first anolyte (4.1) comprises phosphorus compounds, wherein the phosphorus is chemically bonded to calcium (Ca), and/or aluminium (Al), and/or iron (Fe), and/or wherein the particulate material of the first anolyte (4.1) comprises above 0.5 wt% P bonded to Ca, and/or Al, and/or Fe, more preferably above 1 wt% or 1.5 wt%, and most preferably above 2 wt% or 2.5 wt%.

10

5. The apparatus according to any of the preceding claims, wherein the particulate material of the first anolyte (4.1) is suspended in a liquid selected from the group consisting of distilled water, tap water, recycled second anolyte (6.1) and recycled filtrate (3.1), diluted acid, and any combination thereof.

15

6. The apparatus according to any of the preceding claims, configured such that the pH of the first anolyte (4.1) is controlled by a first electrolysytic current, and configured such that the pH decreases during the first electrolysytic treatment.

20

7. The apparatus according to any of the preceding claims, wherein the first catholyte (5.1) is an electrolyte solution, preferably selected from the group consisting of solutions of sodium nitrate, solutions of sodium chloride, solutions of nitric acid, solutions of hydrochloric acid, distilled water, tap water, and recycled first catholyte (5.1).

25

8. The apparatus according to any of the preceding claims, wherein one or more of the compartments (4, 5, 6, 7) further comprises stirring means, and optionally wherein the stirring means are selected from the group consisting of overhead stirrer, magnetic stirrer and stirring by gas bubbling, and/or wherein one or more of the compartments (4, 5, 6, 7) further comprises heating means, and/or wherein the temperature of one or more of the anolytes and/or catholytes (4.1, 5.1, 6.1, 7.1) is above room temperature, and optionally wherein the temperature is above 30 °C, more preferably above 40 °C or 50 °C.

30

35

- 5 9. The apparatus according to any of the preceding claims, wherein the filtration means is selected from the group of filter paper, vacuum filters, and any combination thereof, and optionally wherein the filter mesh size is equal to or below 50 μm , more preferably equal to or below 45 μm , and most preferably equal to or below 40 μm , and optionally further combined with a vacuum filter, and optionally wherein the vacuum filter has a filter mesh size equal to or below 10 μm , more preferably equal to or below 1 μm , and most preferably equal to or below 0.45 μm .
- 10 10. The apparatus according to any of the preceding claims, wherein the second catholyte (7.1) comprises the residual from the filtration means and a further liquid phase, and optionally wherein the further liquid phase is selected from the group consisting of water, distilled water, tap water, sodium hydroxide (NaOH), recycled filtrate from the second filtration means (10.1), and any combination thereof.
- 15 11. The apparatus according to any of the preceding claims, configured such that the pH of the second catholyte (7.1) is controlled by a second electro dialytic current, and configured such that the pH increases during the second
- 20 electro dialytic treatment.
- 25 12. The apparatus according to any of the preceding claims, further comprising second filtration means (10) in fluid communication with the second catholyte compartment (7) configured to filter the second catholyte (7.1) into a second residual and a second filtrate (10.1).
- 30 13. A method for electro dialytic phosphorus recovery, comprising:
(a) providing a first electro dialytic cell (1), comprising a first anolyte compartment (4) and a first catholyte compartment (5), separated by a cation exchange membrane (8);
(b) providing a particulate material comprising acidic and/or alkaline soluble phosphorus compounds;
(c) mixing the particulate material with a liquid and use it as an anolyte for the first cell (4.1);
35 (d) providing an electrolyte solution and use it as a catholyte (5.1) for the first cell;

- (e) applying a first current to the first cell (1) thereby exposing the particulate material to acidic conditions,
whereby metal ions are concentrated in the catholyte (5.1);
- 5 (f) providing a second electrolysytic cell, comprising a second anolyte compartment (6) and a second catholyte compartment (7), separated by an anion exchange membrane (9);
- (g) transferring the treated anolyte (4.1) from the first cell (1) to filtration means such that the treated anolyte is filtered into a residual and a filtrate ;
- (h) transferring the liquid filtrate into the second anolyte compartment (6)
- 10 thereby forming a second anolyte (6.1);
- (i) mixing the residual with water, and transferring the mixture into the second cathode compartment (7) thereby forming a second catholyte (7.1);
- (j) applying a second current to the second cell (2) thereby exposing the particulate material to alkaline conditions,
- 15 whereby phosphorus and phosphorous compounds are concentrated in the second anolyte (6.1).
14. The method according to claim 13, wherein the metal ions concentrated in step (e) comprises calcium ions and/or heavy metal ions.
- 20
15. The method according to any of claims 13-14, wherein the particulate material provided in step (b) is a further batch of particulate material, and step (c)-(j) is repeated thereby defining a second cycle,, and optionally wherein the liquid provided in repeated step (c) is recycled first filtrate (3.1), and/or the filtrate of
- 25 the second catholyte (10.1), and/or the second anolyte (6.1) from the first cycle, and optionally wherein the electrolyte solution of repeated step (d) is the first catholyte from the first cycle.
- 30
- 35

Abstract

The present invention relates to an apparatus for electro dialytic extraction of phosphorus from a particulate material in suspension, a method for electro dialytic phosphorus recovery, and the use of the apparatus and the method for wastewater
5 treatment, and/or treatment of particulate material rich in phosphorus.

The present invention provides an apparatus for electro dialytic extraction of phosphorus from a particulate material comprising acidic and/or alkaline soluble phosphorus compounds, in suspension, comprising:

10 a first electro dialytic cell comprising a first anolyte compartment comprising a first anolyte, and a first catholyte compartment comprising a first catholyte, wherein the compartments of the first cell are separated by a cation exchange membrane, wherein the first anolyte is the particulate material in suspension, the first electro dialytic cell configured for exposing the particulate material to acidic conditions;

15 a second electro dialytic cell comprising a second anolyte compartment comprising a second anolyte, and a second catholyte compartment comprising a second catholyte, wherein the compartments of the second cell are separated by an anion exchange membrane, the second electro dialytic cell configured for exposing the particulate material to alkaline conditions; and

20 filtration means in fluid communication with the first and second electro dialytic cells, and configured to filter the first anolyte, and transfer the residual into the second catholyte compartment to be comprised in the second catholyte, and transfer the filtrate into the second anolyte compartment to be comprised in the second anolyte.

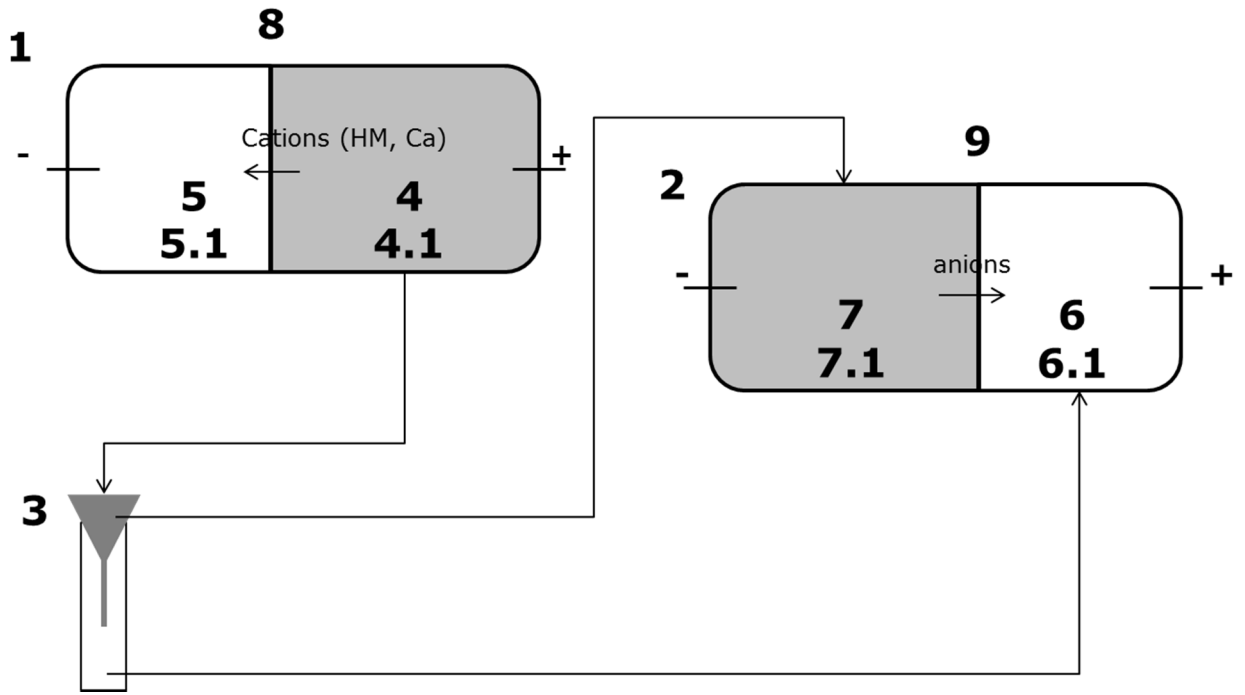

Fig. 1

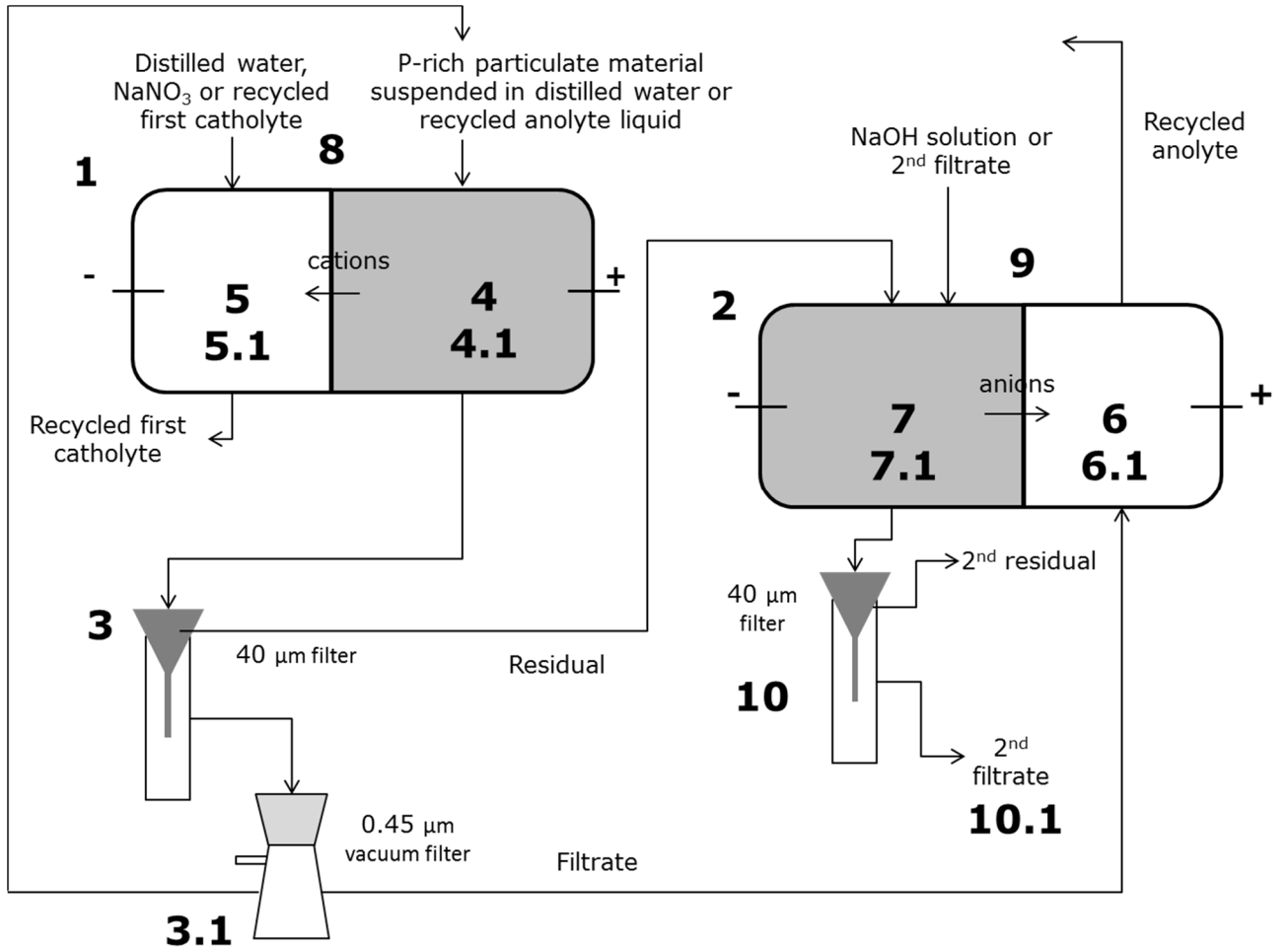

Fig. 2

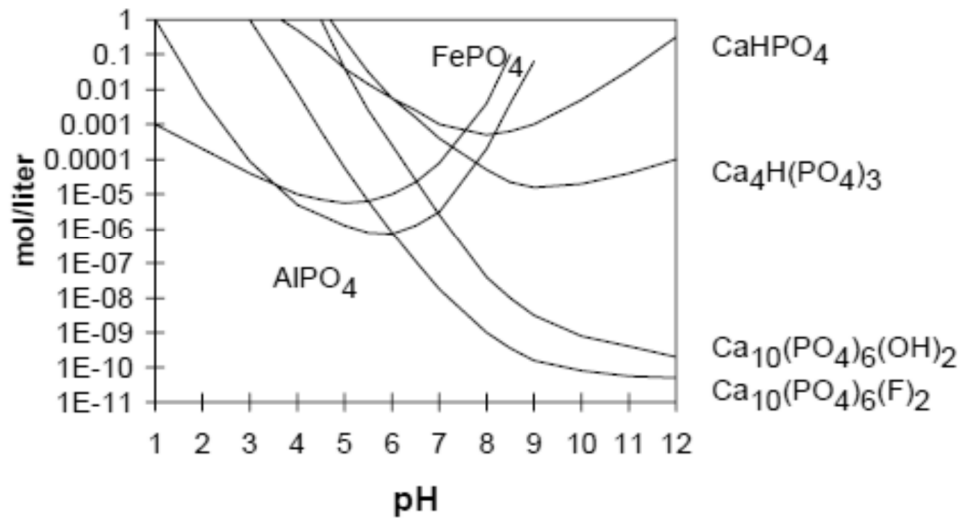

Fig. 3

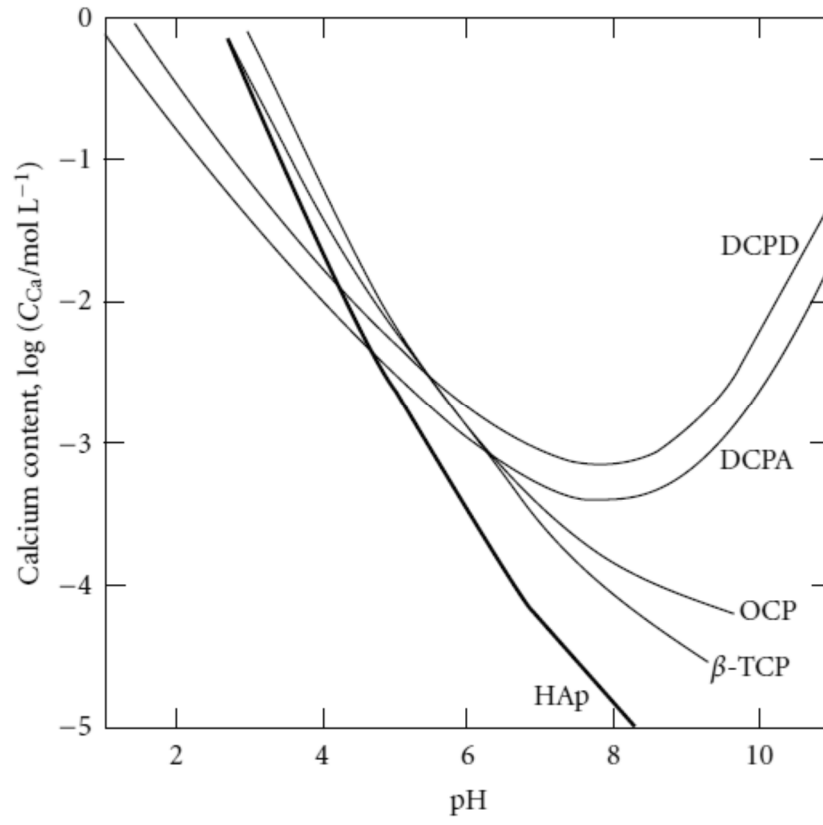

Fig. 4

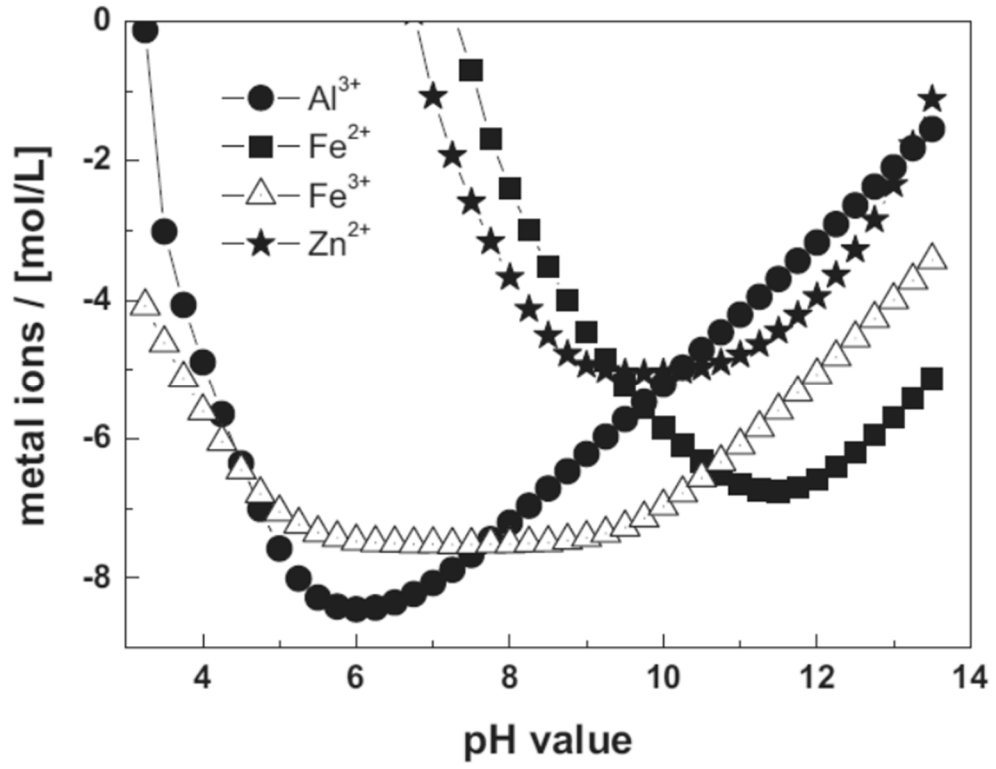

Fig. 5

Appendix – conference contributions

EREM 2014 - Málaga

Motivation

- Worldwide, 120 millions tones of waste are incinerated every year. Municipal solid waste generation is expected to double by 2025 (Hoorweg et al. 2012).
- Incineration of waste generates Air Pollution Control (APC) residues. 2-5% of the original waste by mass (Quinta et al. 2008).
- APC is a hazardous waste; among other reasons, because of its **heavy metal and salt leaching**. At the same time they have a **potential when reused as construction materials** if detoxified.
- Electrodialysis (ED) has previously been proven as an effective technology to reduce the leaching in APC residues.
- Many parameters of ED (membrane used, time of remediation, current density, etc.) have been studied. However, there are **no previous research investigating the influence of different ion exchange membranes** in the remediation of APC residues. This is crucial criterion, because membranes costs change a lot from brand to brand.
- The aim of this research is to evaluate **whether the leaching in the APC treated with ED is influenced by the brand of the membranes used.**

Materials and methods

- 2 different kinds of APC residues were studied:
 - Dry flue-gas cleaning APC: REFA
 - Wet flue-gas cleaning APC: Vestforbrænding
- 4 different membrane brands were investigated:
 - Ionics
 - Neosepta
 - Ralex®
 - Excellion™
- 4-compartment ED cell running at 235 mA for 70 min.

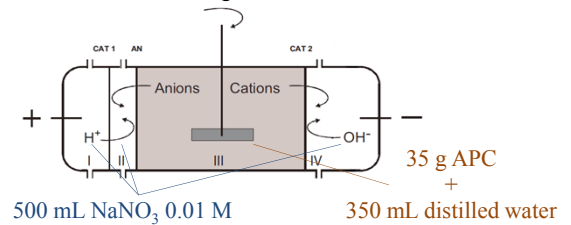

- The leaching tests were done in triplicates according to Danish legislation (DS/EN 12457-1):
 - 40 g of APC+80 mL of water
 - Shaken at 150 rpm for 24 h
 - 45 µm vacuum filtration
 - Filtrates analysed in ICP-OES (metals) and IC (salts)

Results

- Leaching is reduced after the ED treatment, except for Cr and Ni.
- For most of the elements, after an analysis of variance with a $p < 0.05$, the leaching is different among the membranes (Table 1).
- It is possible to reduce leaching values of some elements from above to below Danish legislation limits for the reuse of non-hazardous materials in construction (BEK nr 1662, Category 3). See Table 2.

| Element | Dry APC residue | Wet APC residue |
|-----------------|-----------------|-----------------|
| As | = | = |
| Ba | = | ≠ |
| Cd | = | = |
| Cr | ≠ | ≠ |
| Cu | ≠ | ≠ |
| Mn | = | ≠ |
| Na | ≠ | ≠ |
| Ni | ≠ | = |
| Pb | ≠ | = |
| Zn | ≠ | ≠ |
| Cl | ≠ | ≠ |
| SO ₄ | ≠ | ≠ |

| Element | Dry APC residue | | | | | Wet APC residue | | | | |
|-----------------|-----------------|--------|----------|-------|-----------|-----------------|--------|----------|-------|-----------|
| | Raw APC | Ionics | Neosepta | Ralex | Excellion | Raw APC | Ionics | Neosepta | Ralex | Excellion |
| As | x | ✓ | ✓✓ | ✓ | x | x | ✓ | ✓ | ✓ | ✓ |
| Ba | x | ✓✓ | ✓✓ | ✓✓ | ✓✓ | ✓✓ | ✓✓ | ✓✓ | ✓✓ | ✓✓ |
| Cd | ✓✓ | ✓✓ | ✓✓ | ✓✓ | ✓✓ | ✓✓ | ✓✓ | ✓✓ | ✓✓ | ✓✓ |
| Cr | ✓✓ | x | x | x | x | ✓✓ | ✓ | ✓ | ✓ | x |
| Cu | ✓ | ✓✓ | ✓✓ | ✓✓ | ✓✓ | ✓✓ | ✓✓ | ✓✓ | ✓✓ | ✓✓ |
| Mn | ✓✓ | ✓✓ | ✓✓ | ✓✓ | ✓✓ | ✓✓ | ✓✓ | ✓✓ | ✓✓ | ✓✓ |
| Na | x | ✓✓ | ✓✓ | ✓✓ | ✓✓ | x | ✓✓ | ✓✓ | ✓✓ | ✓✓ |
| Ni | ✓✓ | x | x | ✓✓ | ✓✓ | ✓✓ | x | x | x | ✓ |
| Pb | x | x | x | x | x | x | x | x | ✓✓ | ✓✓ |
| Zn | x | x | x | x | x | x | ✓✓ | ✓✓ | ✓✓ | ✓✓ |
| Cl | x | x | x | x | x | x | ✓✓ | ✓✓ | ✓✓ | ✓✓ |
| SO ₄ | ✓✓ | ✓✓ | ✓✓ | ✓✓ | ✓✓ | x | ✓✓ | ✓✓ | ✓✓ | ✓✓ |

Table 1. Comparison of the leaching behavior among the membranes after ED treatment through ANOVA ($p < 0.05$). ≠: different leaching behaviour. = same leaching behaviour.

Table 2. Comparison of leaching behavior and the Danish legislation limits for non-hazardous materials (BEK nr 1662, Category 3). ✓✓: Not exceeding Category 3 limits within 2 standards deviation ✓: Not exceeding Category 3 limits on average but exceeding within 2 standard deviations x: Exceeding Category 3 limits on average.

Conclusions

- Leaching behaviour is influenced by the membrane used for the majority of the studied elements.
- Although the leaching is reduced on average from above to below Category 3 for some elements, no membrane is able to reduce all elements below these limits under the experimental conditions of this research.



IWARR 2015

Aim: Phosphorus

- Phosphorous is a limited resource and an **essential nutrient**.
- Phosphate rock (P-rock) reserves are foreseen to be **depleted in 300-400 years** [1].
- In the last decade, the **EU imported around 90 % of the P-rock** that it consumed (IFA).
- In the EU there is a flow of 182,000 t of **non-recycled P yearly in sewage sludge**, around 20% of the EU P-rock consumption (Van Dijk et al. (submitted)).
- A common practice in some countries (AT, BE, CH, DE, DK, NL, US, JP, HK) is **incineration** of sewage sludge. In recent years, **gasification** has gained attention.

Low-temperature gasification technology

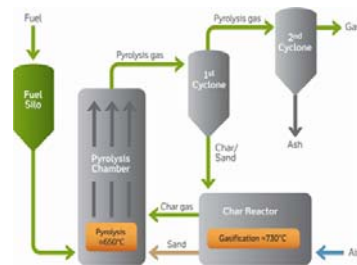

- Due to the low temperature it is possible to use high alkaline fuels. Examples: straw, sewage sludge, etc.
- The resulting ashes, might have a high content in heavy metals or have a poor P-plant availability

Electrodialysis: a technology to recover P from sewage sludge ashes

- A patent has been filed from DTU (WO 2015/032903) for the 2-compartment Electrodealytic (ED) cell.

Anolyte liquid:

- P-rich
- Acidic (H^+ generated in the anode)
- Low in heavy metals

Bulk ash: can be reused in construction industry

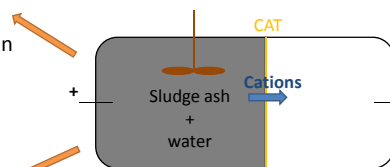

Figure 1. Two-compartment ED cell

- With this setup (Figure 1), it is possible to recover up to **90% of P from incineration sewage sludge ashes**, in the anolyte liquid with low content in heavy metals (Cd, Cr, Cu, Ni, Pb, Zn) [2].
- **Only 26% of P** was recovered with the same setup at the same conditions (liquid-to-solid ratio, current density and experimental time) with **gasification sewage sludge ashes** [3]. Most likely, due to the presence of **Fe-P bindings** (Figure 2). Poor results were previously observed for ashes with high Al content [4].
- **Up to 70% of P** was eventually recovered for the same ashes with an innovative ED setup. The recovered P-liquid has a content in heavy metals **comparable to the one of wet phosphoric acid** (Figure 3). The new setup is currently being drafted for a patent filing.
- Further work will focus on sewage sludge ashes containing both **high content of both Fe and Al**.

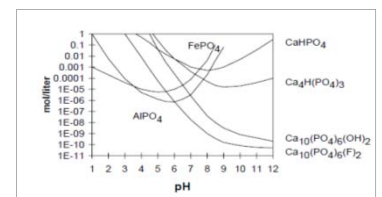

Figure 2. Solubility of Al-P, Ca-P and Fe-P compounds

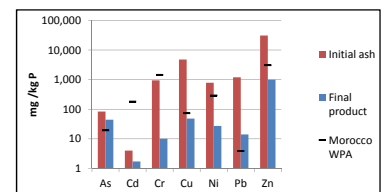

Figure 3. Heavy metal to P ratio of the ash, anolyte liquid (final product) and wet phosphoric acid



Figure 4. Different sewage sludge ashes

References

- [1] C.J. Dawson, J. Hilton, Fertiliser availability in a resource-limited world: Production and recycling of nitrogen and phosphorus, Food Policy 36 (Jan) (2011) S14–S22.
- [2] B. Ebberts, L.M. Ottosen, P.E. Jensen, Comparison of two different electrodealytic cells for separation of phosphorus and heavy metals from sewage sludge ash, Chemosphere (2015)
- [3] R. Parés Viader, P. E. Jensen, L. M. Ottosen, J. Ahrenfeldt, and H. Hauggaard-Nielsen, "Electrodialytic extraction of phosphorus from ash of low-temperature gasification of sewage sludge," Electrochimica Acta (2015).
- [4] L.M. Ottosen, P.E. Jensen, G.M. Kirkelund, Electrodealytic Separation of Phosphorus and Heavy Metals from Two Types of Sewage Sludge Ash, Separation Science and Technology 49 (2014) 1910–1920.

The present PhD study aims to investigate the separation of phosphorus from heavy metals in different ashes produced from Pyroneer gasification of sewage sludge, some of which had a high presence of alkaline-soluble aluminium- and iron-phosphates. Using different electrodialytic methods, including a setup for which a patent was filed, at least 70% of phosphorus was recovered. Moreover, the product was a solution with impurity levels of iron, aluminium and heavy metals comparable to wet process phosphoric acid, widely used in the manufacturing of fertilizers.

DTU Civil Engineering
Technical University of Denmark

Brovej, Bygning 118
2800 Kongens Lyngby

www.byg.dtu.dk

ISBN 9788778774538
ISSN 1601-2917